

TECHNICAL MANUAL

**OPERATOR, UNIT, DIRECT SUPPORT
AND GENERAL SUPPORT
MAINTENANCE MANUAL
(INCLUDING REPAIR PARTS AND
SPECIAL TOOLS LIST)**

FOR

**WATER PURIFICATION BARGES
(NSN 1930-01-234-2165)
VOLUME 2
SEAWATER SYSTEM**

This technical manual is an authentication of the manufacturer's commercial literature and does not conform with the format and content requirements normally associated with the Army technical manuals. This technical manual does, however, contain all essential information required to operate and maintain the equipment

DISTRIBUTION STATEMENT A: Approved for public release; distribution is unlimited

***This manual supersedes TM 55-1930-209-14&P-2, 30 January 1989.**

**HEADQUARTERS, DEPARTMENT OF THE ARMY
15 OCTOBER 1992**

WARNINGS AND SAFETY NOTICES

WARNING

DANGEROUS VOLTAGES AND HAZARDOUS MATERIALS
ARE USED IN THIS EQUIPMENT.
DO NOT TAKE CHANCES!

GENERAL WARNINGS

- Always redtag electrical equipment, controls, circuits, and switches before beginning repairs.
- Do not service or adjust high voltage electrical equipment when alone.
- Do not overload circuits.
- Always use authorized, insulated tools and test equipment when working on electrical equipment.
- Remove all jewelry before working on or around electrical equipment with exposed current-carrying areas.
- Do not wear clothing with exposed metal fasteners when working on electrical equipment.
- Always use approved breathing apparatus when working with chemicals.
- Avoid chemical contact with eyes, skin, and clothing.
- Always wear safety glasses, gloves, and rubber aprons when handling chemicals.
- Wear protective clothing and safety glasses as required when working on barge equipment.
- Always wear approved ear protection in noise hazard areas.

SPECIFIC WARNINGS

- Do not connect any new circuit to an existing circuit.
- Do not energize circuits if water condensation is present.
- If any sparks are seen, stop operation immediately. Determine cause and take corrective action.
- Never touch radio antennas of fixed-base radio transmitters. When transmitting, antennas contain high voltage.
- Always use approved breathing apparatus when handling material in multimedia filters and chlorination unit descaling acid crystals. Do not breathe dust from these materials.
- Avoid breathing vapors from coagulant aid chemicals. Use in a well-ventilated area. In case of chemical contact with skin, wash with water. For eyes, immediately flush at eyewash station and obtain medical help as soon as possible.
- Always wear work gloves and shirts with full length buttoned sleeves when handling fuel oil and gasoline.

- Do not smoke or have open flames within 10 feet when handling fuel oil or gas. Only minimum number of personnel necessary to conduct fueling operation is permitted in area.
- Before starting any repairs on compressed air system, always release pressure from air receiver and compressor and open and retdag circuit breakers.
- On air compressor, do not adjust automatic regulator switch (pressure switch) and pilot valve settings.
- To avoid flying particles lodging in eyes, do not use compressed air to 'dust-off" clothing or workspace.
- Stay clear of anchor cables when operating anchor winches.
- Always wear safety glasses or face shield when using power tools.
- Always wear lifevests when on weatherdeck and throughout the barge during storm conditions.
- Lifevests are to be worn at all times aboard workboat.
- Only qualified persons will operate and maintain arc and fuel gas welders.
- When welding, always make sure those working with or near the welder wear proper clothing: heavy, hole-free gloves, heavy shirt, cuffless trousers, high shoes, and cap. Keep clothing dry and free of oil and other flammable substances.
- Use dry heavy canvas drop cloth to cover work area and adjacent deck when arc welding.
- Before welding on bulkheads, deck plating and similar surfaces, always check carefully to make sure that the other side of the surface to be welded does not hide fuel or compressed gas tanks, flammable or hazardous materials, or electrical equipment or wiring.
- When welding, keep your head out of the fumes and make sure area is well ventilated.
- Before welding on surfaces which have been cleaned with cleaning solutions containing chlorinated hydrocarbons, always wash with water, dry and ventilate area thoroughly.
- Use shield with proper filter lens when welding. Do not allow others near welding operations to assist or observe without proper eye protection. This must include side shields during slag chipping operations.
- Warn personnel in area during welding operations not to look at arc or expose themselves to hot spatter or metal.
- In an extreme emergency, when welding is required in void 2 port, shut down chlorination system. Close all valves. Cover the parts of chlorination system not being welded with a heavy canvas drop cloth. Turn on vent 8 and, if available, provide additional forced air ventilation.

- Before welding on fuel oil or sludge tank, make sure tank is gas-free by: 1) removing all liquid from tank, 2) cleaning tank thoroughly, 3) seeing that tank is thoroughly dry, and 4) force ventilating tank.
- Connect arc welding work cable as close to welding area as possible. Work cables connected to barge framework or other locations far from welding site increase the possibility of the welding current passing through lifting chains, crane cables or other possible circuit paths. This can create fire hazards or weaken lifting chains or crane cables until they break or fall.
- Always weld with all doors, portholes, and hatches propped open and necessary ventilation systems operating.
- Take frequent breaks away from the area where you are welding.
- Do not take oxygen and acetylene tanks into confined areas when welding.
- Always use a friction lighter to start oxyacetylene torch.
- Always maintain all welding equipment in proper working condition. If you have any doubts about the safety of any welding equipment, do not use the welder.

ELECTRICAL SHOCK SAFETY STEPS

Five safety steps to follow if someone is the victim of electrical shock.

1. Do not try to pull or grab individual.
2. Turn off electrical power when possible.
3. If you can not turn off electrical power, pull, push, or lift person to safety using a wooden pole, rope, or some other insulating material.
4. Get medical help as soon as possible.
5. After the injured person is free of contact with the source of electrical shock, move the person a short distance away and, if needed, start CPR immediately.

INTRODUCTION TO**TM 55-1930-209-14&P-2**

You can help improve this manual. If you find any mistakes or if you know of a way to improve the procedures, please let us know. Mail your letter, DA Form 2028 (Recommended Changes to Publications and Blank Forms), or DA Form 2028-2 located in the back of this manual direct to: Commander, US Army Troop Support Command, ATTN. AMSTR-MMTS, 4300 Goodfellow Blvd., St Louis, MO 63120-1798. A reply will be furnished directly to you.

1. SCOPE

TM 55-1930-209-14&P covers the Reverse Osmosis Water Purification Barges, Models 300-WPB-1, 300-WPB-2 and 300-WPB-3, NSN 1930-01-234-2165. This manual consists of twenty-one volumes.

2. REVERSE OSMOSIS WATER PURIFICATION BARGES

The Reverse Osmosis Water Purification Barges provide up to 300,000 gallons of drinking water per 24 hour period. The drinking water, converted from seawater or brackish water, is for use by a Rapid Deployment Force in a forward area. When needed, the drinking water can be pumped to a shore facility or to another vessel. This manual provides operation and maintenance procedures for all the component systems on the barges.

3. VOLUME 1 -- NORMAL OPERATIONS

This volume provides information and procedures on normal Reverse Osmosis Water Purification Barge operations, including barge movement and deployment, communications and electrical power systems, drinking water production, shutdown, and required operational maintenance. Emergency shutdown procedures are also provided.

4. VOLUME 2 -- SEAWATER SYSTEM

This volume describes operation and maintenance of the seawater system which supplies seawater to the Reverse Osmosis Water Purification Units (ROWPUs) for processing to the air conditioning unit for cooling to the ballast tank for barge trimming to the chlorination unit for priming and cooling, and to the diesel generators for cooling.

5. VOLUME 3 -- REVERSE OSMOSIS WATER PURIFICATION UNIT (ROWPU) SYSTEM

Volume 3 provides operation and maintenance procedures for the ROWPU System which processes seawater or brackish water to produce drinking water. Normally, this system processes seawater supplied by the seawater system (TM 55-1930-209-14&P-2) to create product water. Chlorine is then added to this product water by the chlorination system (TM 55-1930-209-14&P-4). The resultant drinking water is discharged into four storage tanks that are part of the drinking water system (TM 55-1930-209-14&P-5).

6. VOLUME 4 -- CHLORINATION SYSTEM

Operation and maintenance procedures for the chlorination system onboard the Water Purification Barges are contained in this volume. This system produces chlorine in a sodium hypochlorite solution, upon demand, to water processed by the ROWPU system just before the water enters the four drinking water storage tanks.

7. VOLUME 5 -- DRINKING WATER SYSTEM

The drinking water system provides storage for water produced by the ROWPUs and includes pumps and valves to move this water from onboard storage tanks to the shore discharge system, to another vessel, or overboard. The drinking water system also provides a pressurized water supply for drinking and washing onboard the barges.

8. VOLUME 6 -- SHORE DISCHARGE SYSTEM

This volume provides operation and maintenance procedures for the shore discharge system which transfers drinking water from barge storage tanks to holding/storage facilities ashore.

9. VOLUME 7 -- COMPRESSED AIR SYSTEM

Volume 7 describes the operation and maintenance of the compressed air system which provides compressed air to five air stations in the ROWPU space, one in the workshop, and one on stem weatherdeck. This system also provides compressed air to two air stations for blowdown of seachests in void 2 starboard and void 4 port. Compressed air is used on the barges to operate air-powered impact tools, to propel air through the shore discharge hose, to blowdown seachest, and for general cleaning blowdown.

10. VOLUME 8 -- FUEL OIL SYSTEM

This volume provides operation and maintenance procedures for the fuel oil system which functions as a centralized receiving storage and distribution system for diesel fuel used for barge operations. This onboard fuel system provides fuel for two 155 kW diesel ship service generators, a 20 kW ship auxiliary generator, two ROWPU high-pressure pump diesel engines, and a fueling station for the barge workboat.

11. VOLUME 9 -- ELECTRICAL POWER SYSTEMS

Operation and maintenance procedures for the two electrical power systems installed aboard the Water Purification Barges are contained in Volume 9. The normal electrical power system generates, controls and distributes all electrical power for operating the water purification system and its auxiliary systems. The emergency electrical system supplies 24 Vdc from a battery bank to 24 Vdc equipment and converts to 24 Vdc through an inverter to 120 Vac to power emergency lighting and equipment.

12. VOLUME 10 -- LIGHTING SYSTEM

Volume 10 contains operation and maintenance procedures for the onboard lighting systems for the Water Purification Barges. This system supplies interior and exterior lighting. Normal and emergency interior lighting is provided in the deckhouse ROWPU space, dayroom, workshop, and voids. Exterior lighting consists of searchlights and floodlights for use at night or during reduced visibility. Lights on the weatherdecks and standard navigation and status lights are for use during operation and towing.

13. VOLUME 11 -- EQUIPMENT MONITORING SYSTEM

This volume provides operation and maintenance procedures for the equipment monitoring system which monitors the operation of several equipment components onboard the Water Purification Barges. This system monitors operating conditions such as amount of drinking water in storage tanks and temperature of diesel engine cooling water. Sensors detect unacceptable operating conditions, the main processor flashes at double intensity and remote alarms (horns, strobe lights and buzzer alert crewmembers that corrective action is necessary).

14. VOLUME 12 -- COMMUNICATIONS SYSTEM

Operation and maintenance procedures for the communications system are provided in Volume 12. This system consists of three separate communications methods, radio communications, foghorn and intercom telephones.

15. VOLUME 13 -- HANDLING EQUIPMENT

This volume contains operation and maintenance procedures for handling equipment used for lifting, transporting and repositioning equipment and materials onboard the barges. The system includes a bridge crane, bow crane and a void 4 trolley hoist.

16. VOLUME 14 -- ANCHOR, MOORING, AND TOWING EQUIPMENT

Volume 14 describes the operation and maintenance procedures for the anchor mooring, and towing equipment on the Water Purification Barges. This equipment provides a method to hold (anchor) the barges in a fixed position offshore, at dockside, or next to another vessel and a method to move the barges from one location to another.

17. VOLUME 15 -- MISCELLANEOUS EQUIPMENT (DAYROOM, WORKSHOP, ACCESSES, AND SANITATION SYSTEMS)

Volume 15 addresses operation and maintenance procedures for miscellaneous equipment installed on the Water Purification Barges. This equipment includes the dayroom on the forward starboard side of deckhouse, the workshop on the forward portside of deckhouse, accesses such as deckhouse doors and portholes and various accesses to and from the voids, and two separate sanitation systems (toilets and bilge). Additional equipment addressed in this volume includes: guard rails, rubber fendering, removable rubber floor mats, eyewash stations, component labels, caution, warning and danger signs, and storage areas.

18. VOLUME 16 -- VENTILATION, HEATING, AND AIR CONDITIONING SYSTEMS

This volume contains operation and maintenance procedures for the deckhouse and voids ventilation systems and the heating and air conditioning (HAC) system installed on the Water Purification Barges. The ventilation system provides fresh air circulation in the deckhouse and voids with 17 hatches and 10 ventilation fans. The HAC controls the temperature in the dayroom and deckhouse.

19. VOLUME 17 -- WORKBOAT, LIFESAVING, AND FIREFIGHTING EQUIPMENT

Volume 17 includes procedures for the operation and maintenance of:

- a. Workboat -- provides water transportation for crew members and visitors, small cargo items, transportation of the messenger line for the shore discharge hose and similar work-related tasks associated with operating the Water Purification Barges.
- b. Lifesaving Equipment -- installed on the barges and consisting of 2 liferafts, 15 Type II and 24 Type V lifevests and 4 lifesaving rings.
- c. Firefighting Equipment -- installed on the barges and consisting of Halon 1301 system, 2 CO₂ hose reel units, a smoke detector system, 17 portable CO₂ fire extinguishers, 5 dry chemical fire extinguishers, 5 self-contained breathing apparatuses, and a portable, engine driven firefighting pump. The workboat also has a 10-pound, portable, dry chemical fire extinguisher.

20. VOLUME 18 SUPPORTING APPENDICES FOR VOLUMES 1-17.

Volume 18 contains the Maintenance Allocation Chart, Components of End Item List, Tools and Test Equipment List, Expendable/Durable Supplies and Materials List and the Repair Parts and Special

All of the information contained in this volume is common to volumes 1-17 and does not appear in each individual volume.

Appendix A in volumes 1-17 provides information unique to each volume. Appendix B in volumes 1-17 provides manufacturers manuals and instructions unique to the system described in each volume. Appendixes C-G are located in Volume 18.

21. VOLUME 19 -- PREVENTIVE MAINTENANCE CHECKS AND SERVICES

(PMCS) Volume 19 contains PMCS pertinent to all onboard systems for the Reverse Osmosis Water Purification Barges.

22. VOLUME 20 -- SUPPLEMENTAL DATA

Volume 20 contains the Basic Issue Items List, and additional Authorization List for all onboard systems for the Reverse Osmosis Water Purification Barges.

23. VOLUME 21 -- WINCH, DOUBLE DRUM, DIESEL

This volume contains operation and maintenance procedures for the 20-ton double drum diesel engine winch used on the Water Purification Barges Appendix B of Volume 21 contains the Maintenance Allocation Chart and the Repair Parts and Special Tools List for the winch.

TECHNICAL MANUAL
NO. 55-1930-209-14&P-2

HEADQUARTERS
DEPARTMENT OF THE ARMY,
WASHINGTON D.C., 15 OCTOBER 1992

TECHNICAL MANUAL

OPERATORS', UNIT, DIRECT SUPPORT
AND GENERAL SUPPORT
MAINTENANCE MANUAL
(INCLUDING REPAIR PARTS AND
SPECIAL TOOLS LIST)

FOR
WATER PURIFICATION BARGES
(NSN 1930-01-234-2165)
VOLUME 2
SEAWATER SYSTEM

REPORTING ERRORS AND RECOMMENDING IMPROVEMENTS

You can help improve this manual. If you find any mistakes or if you know of a way to improve the procedures, please let us know. Mail your letter, DA Form 2028 (Recommended Changes to Publications and Blank Forms), or DA Form 2028-2 located in the back of this manual direct to: Commander, US Army Troop Support Command, ATTN: AMSTR-MMTS, 4300 Goodfellow Blvd., St. Louis, MO 63120-1798. A reply will be furnished directly to you.

DISTRIBUTION STATEMENT A: Approved for public release; distribution is unlimited

* Supersedes TM 55-1930-209-14&P-2, 30 January 1989

A/(B blank)

TABLE OF CONTENTS

VOLUME 2

	<u>Page</u>
CHAPTER 1 INTRODUCTION	1-1
Section I. General Information	1-1
1-1 Purpose	1-1
1-2 Scope	1-1
1-3 Warranties and guarantees	1-1
1-4 Maintenance forms and records	1-1
1-5 Destruction of Army materiel to prevent enemy use.....	1-1
1-6 Storage.....	1-1
Section II. Description and data	1-1
1-7 Description	1-1
1-7.1 ROWPU and ballast seawater supply	1-1
1-7.2 Air conditioner cooling seawater and chlorination unit seawater supply	1-1
1-7.3 Diesel engine generator cooling seawater	1-1
1-8 Capabilities.....	1-11
1-8.1 System capability definitions	1-11
1-9 Special limitations	1-11
1-10 Performance characteristics	1-11
1-11 Equipment specifications	1-11
1-12 Items furnished	1-26
1-13 Items required but not furnished.....	1-26
1-14 Tools and test equipment	1-26
CHAPTER 2 DESCRIPTION OF OPERATION.....	2-1
2-1 ROWPU seawater supply.....	2-1
2-2 Ballast seawater supply	2-1
2-3 Air conditioning unit seawater supply.....	2-1
2-4 Chlorination unit seawater supply.....	2-1
2-5 Diesel generators seawater supply.....	2-1
CHAPTER 3 OPERATING INSTRUCTIONS	3-1
Section I. Operating controls and indicators	3-1
3-1 Operating controls and indicators	3-1

TABLE OF CONTENTS (Continued)

VOLUME 2

	<u>Page</u>
Section II. Prestart procedures	3-1
3-2 Prestart procedures	3-1
Section III. Operating procedures	3-1
3-3 Normal and alternate operating procedures	3-1
3-3.1 Supplying seawater to ROWPU's from seachest (deep water) using seawater pump(s) 1 and/or 2	3-10
3-3.1.1 Normal procedures	3-10
3-3.1.2 Alternate procedures	3-11
3-3.2 Supplying seawater to ROWPU's from starboard shell penetration (shallow water) using seawater pump(s) 1 and/or 2	3-11
3-3.2.1 Normal procedures	3-12
3-3.2.2 Alternate procedures	3-12
3-3.3 Supplying seawater from seawater pumps to chlorination and air conditioning units	3-13
3-3.4 Supplying seawater from cooling pump to air conditioning and chlorination units	3-14
3-3.5 Filling ballast tank (to correct a bow high condition)	3-14
3-3.5.1 Filling ballast tank from forward seachest	3-14
3-3.5.2 Filling ballast tank from starboard shell	3-15
3-3.6 Draining ballast tank (to correct a stern high condition)	3-15
3-3.7 Supplying seawater for generator cooling	3-16
3-3.8 Seachest blowdown	3-17
3-3.8.1 Forward seachest blowdown	3-17
3-3.8.2 Aft seachest blowdown	3-17
3-4 Seawater system shutdown procedures	3-18
3-4.1 Shutdown seawater supply to ROWPU's	3-18
3-4.2 Shutdown generator cooling seawater supply	3-18
3-4.3 Shutdown seawater supply to air conditioning and/or chlorination units when using cooling pump	3-18
3-5 Emergency shutdown	3-18
3-5.1 General	3-19
3-5.2 Emergency shutdown procedures	3-19

TABLE OF CONTENTS (Continued)

VOLUME 2

	<u>Page</u>
Section IV. Operation under extreme conditions	3-19
3-6 Operation under extreme conditions	3-19
3-6.1 Operation in extreme cold	3-19
3-6.2 Operation in extreme heat	3-19
CHAPTER 4 MAINTENANCE INSTRUCTIONS	4-1
Section I. General	4-1
4-1 Maintenance concept	4-1
4-2 Maintenance instruction.....	4-1
Section II. Preventive maintenance checks and services	4-1
Section III. Troubleshooting.....	4-1
4-4 Component	4-1
4-5 Seawater system	4-1
Section IV. Maintenance procedures	4-1
4-6 General	4-1
4-7 Seawater system	4-7
4-7.1 Lubrication	4-8
4-7.2 Repair or replacement of system components	4-8
4-7.2.1 Seawater discharge pump assembly	4-8
4-7.2.2 Seachest (Void 2 starboard or Void 4 port)	4-9
4-7.2.3 Seawater strainer	4-9
4-7.2.4 Strainer inlet and outlet pressure gauges.....	4-11
4-7.2.5 Seawater filter 1 and 2 (Lakos separator)	4-12
4-7.2.6 Seawater discharge pump OFF/ON/START and local START/STOP switches	4-12
4-7.2.7 Cooling pump motor controller	4-14

TABLE OF CONTENTS (Continued)

VOLUME 2

	<u>Page</u>
4-7.2.8	Cooling pump 4-17
4-7.2.9	Pressure regulator (chlorination unit seawater supply line) 4-18
4-7.2.10	Pressure gauge (chlorination unit seawater supply line) 4-18
4-7.2.11	Seawater to chlorination in-line filter 3 4-19
4-7.2.12	Seachest and ballast tank air escape valve 4-19
4-7.2.13	Generator cooling inlet and outlet temperature gauges 4-20
4-7.2.14	Ballast tank 4-20
4-7.2.15	Ballast tank liquid level indicator 4-21
4-7.2.16	Piping and valves 4-22
CHAPTER 5	STORAGE 5-1
5-1	Short-term storage 5-1
5-2	Administrative storage 5-1
5-2.1	Administrative storage procedures, generators in use 5-1
5-2.2	Administrative storage procedures, generators off 5-2
5-2.3	Administrative storage inspection 5-2
5-3	Long-term storage 5-2
CHAPTER 6	MANUFACTURER'S SERVICE MANUALS/INSTRUCTIONS 6-1
6-1	General 6-1
CHAPTER 7	MANUFACTURERS' WARRANTIES/GUARANTEES 7-1
7-1	General 7-1

LIST OF APPENDICES

A	REFERENCES A-1
B	MANUFACTURERS' SERVICE MANUALS/INSTRUCTIONS B-1
C	PREVENTIVE MAINTENANCE CHECKS AND SERVICES C-1

NOTE

The following appendices, common to all TM's in this series are in TM-55-1930-209-14&P-18.

MAINTENANCE ALLOCATION CHART (MAC)
 TOOLS AND TEST EQUIPMENT (TTEL)
 EXPENDABLE/DURABLE SUPPLIES AND MATERIALS LIST
 REPAIR PARTS AND SPECIAL TOOLS LIST (RPSTL)

NOTE

The following appendices, common to all TM's in this series are in TM-55-1930-209-14&P-20.

COMPONENTS OF END ITEM LIST (COEIL) and BASIC ISSUE ITEMS LIST (BILL)
 ADDITIONAL AUTHORIZED ITEM LIST (AAL)

TABLE OF CONTENTS (Continued)

VOLUME 2

LIST OF ILLUSTRATIONS

<u>Figure</u>		<u>Page</u>
1-1	Barge Major Components	1-2
1-2	ROWPU and Ballast Seawater Supply	1-5
1-3	ROWPU and Ballast Seawater Supply Block Diagram	1-7
1-4	Air Conditioner Cooling Seawater and Chlorination Unit, Seawater Supply	1-8
1-5	Air Conditioner and Chlorination Unit Cooling Seawater Block Diagram	1-10
1-6	Diesel Engine Generator Cooling Seawater	1-22
1-7	Diesel Engine Generator Cooling Seawater Block Diagram (Barge 1)	1-24
1-8	Diesel Engine Generator Cooling Seawater Block Diagram (Barges 2 and 3)	1-25
3-1	Seawater System's Electrical Controls	3-3
3-2	ROWPU Control Station (ROWPU 1 Station Shown)	3-4
3-3	Ballast Tank Liquid Level Indicator	3-5
3-4	Location of Control Buttons for Emergency Shutdown Systems	3-20
4-1	ROWPU Control Station Schematic	4-2
4-2	Cooling Pump Motor Controller Schematic	4-3

LIST OF TABLES

<u>Table</u>		<u>Page</u>
1-1	Major Components of ROWPU and Ballast Seawater Supply	1-6
1-2	Major Components of Air Conditioner Cooling Seawater and Chlorination Unit Seawater Supply	1-9
1-3	Major Components of Diesel Engine Generator Cooling Seawater	1-23
3-1	Operating Controls and Indicators	3-2
3-2	Seawater System Valves	3-6
4-1	Seawater Discharge Pump and Cooling Pump Troubleshooting	4-2
4-2	Cooling Pump Motor Controller Troubleshooting	4-3
4-3	Seawater System Troubleshooting.....	4-4

CHAPTER 1 INTRODUCTION

Section I. General Information

1-1 Purpose. This Technical Manual (TM) describes operation and maintenance of the seawater system installed onboard Water Purification Barges. Information on other onboard systems is in TM 55-1930-209-14 & P-1, and P-3 thru P-17. TM 55-1930-209-14 & P-18 contains appendices common to all TM's. Location of major barge components is shown in Figure 1-2.

1-2 Scope. The seawater system supplies seawater to the Reverse Osmosis Water Purification Units (ROWPU's) for processing, to the air conditioning unit for cooling, to the ballast tank for barge trimming, to the chlorination unit for priming and cooling, and to the diesel generators for cooling.

1-3 Warranties and guarantees. Warranty and guarantee information is in Chapter 7.

1-4 Maintenance forms and records. Required maintenance forms and records are explained in DA PAM 738-750, The Army Maintenance Management System (TAMMS).

1-5 Destruction of Army materiel to prevent enemy use. This shall be as directed in TM 750-244-3.

1-6 Storage. For storage procedures concerning this system, refer to Chapter 5.

Section II. Description and data

1-7 Description

1-7.1 ROWPU and ballast seawater supply. This installation (Figure 1-3) consists of a forward seachest, two seawater strainers with pressure gauges, two seawater filters, two seawater pumps, ballast tank and associated piping, valves, and electrical circuitry. This arrangement supplies seawater to the ROWPU's, to the ballast system, and to the chlorination unit. Information about major components is listed in Table 1-1. A block diagram is shown in Figure 1-4. Onboard installation and electrical hookup are shown in drawings listed in Appendix A.

1-7.2 Air conditioner cooling seawater and chlorination unit seawater supply. This installation (Figure 1-5) consists of a seawater strainer with gauges, seawater filter, pressure regulator with gauge, cooling pump and associated piping, valves, and electrical circuitry. When seawater pumps are not operating, this arrangement can supply seawater to the air conditioning unit for cooling and to the chlorination unit for cooling and producing chlorine. Information about major components is listed in Table 1-2. A block diagram is shown in Figure 1-1. Onboard installation and electrical hookup are shown on drawings listed in Appendix A.

1-7.3 Diesel engine generator cooling seawater. This installation (Figure 1-6) consists of an aft seachest, a seawater strainer, temperature gauges on each generator set, associated piping, valves, and electrical circuitry. This arrangement supplies cooling seawater to diesel engine generator sets. Information about major components is in Table 1-3. A block diagram is shown in Figure 1-7 for Barge 1 and in Figure 1-8 for Barges 2 and 3. Onboard installation is shown on drawings listed in Appendix A.

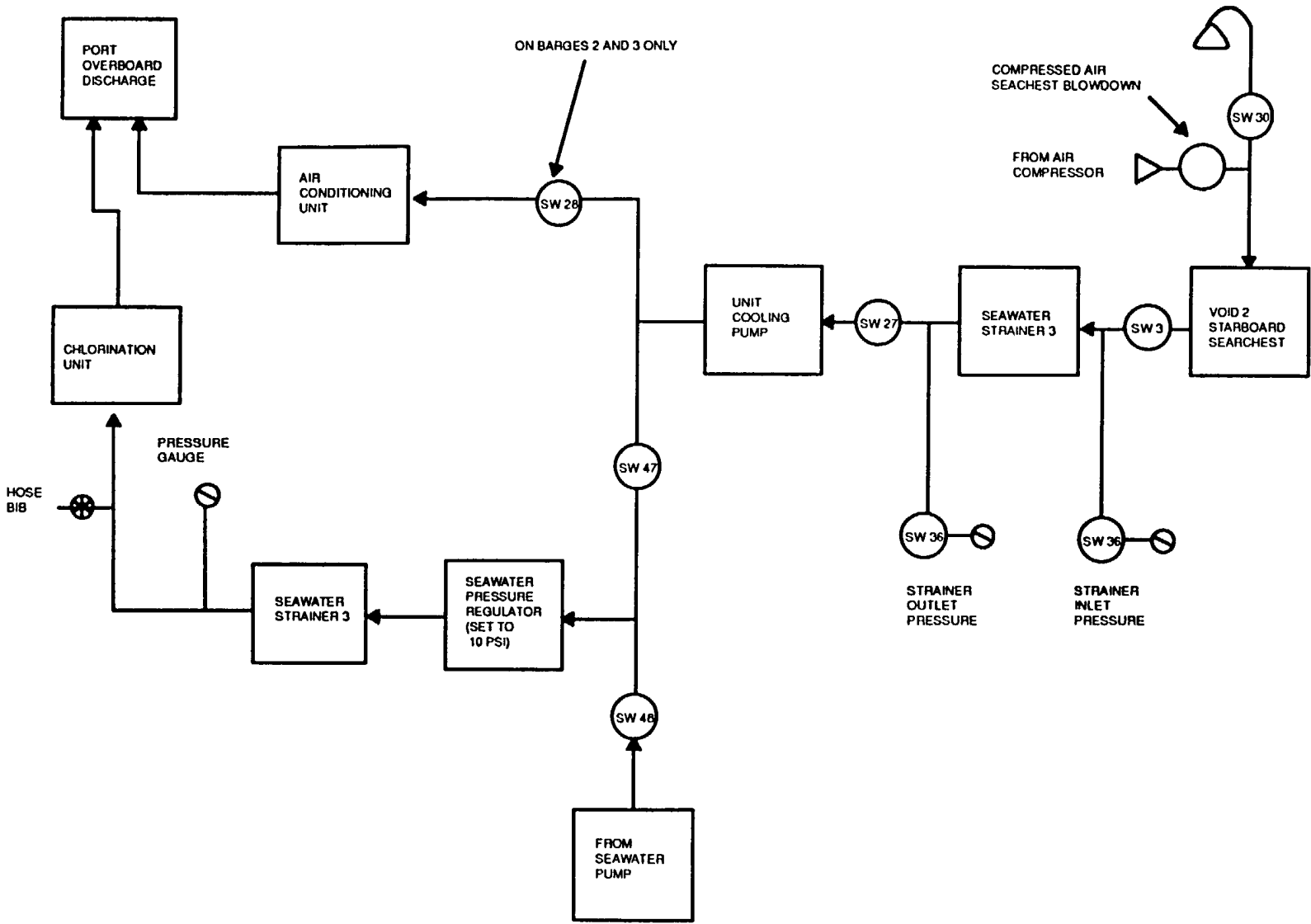

Figure 1-1. Air Conditioner and Chlorination Seawater Cooling Block Diagram

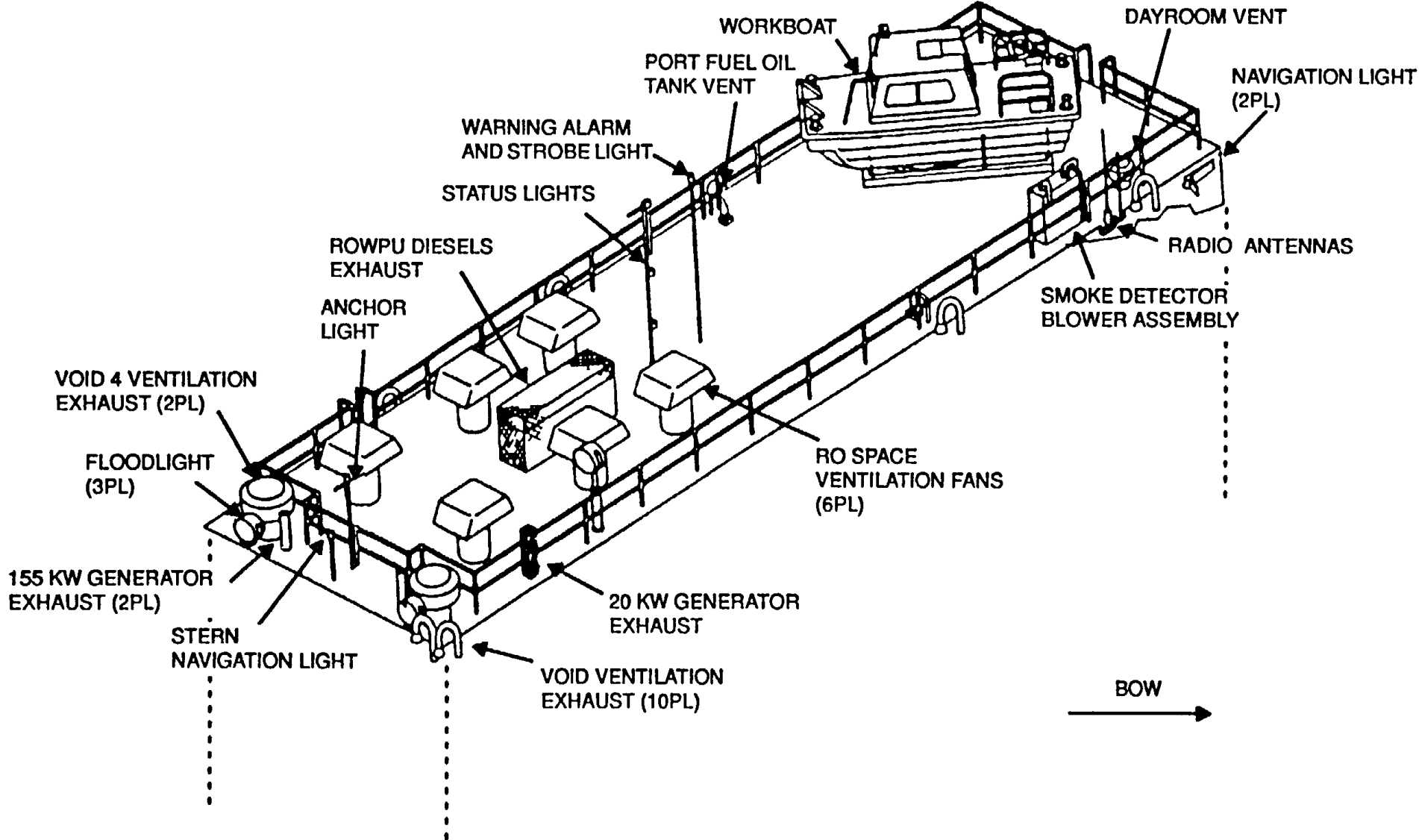

Figure 1-2. Major Components of ROWPU Barge Systems and Equipment - Deckhouse Roof (Sheet 1 of 3)

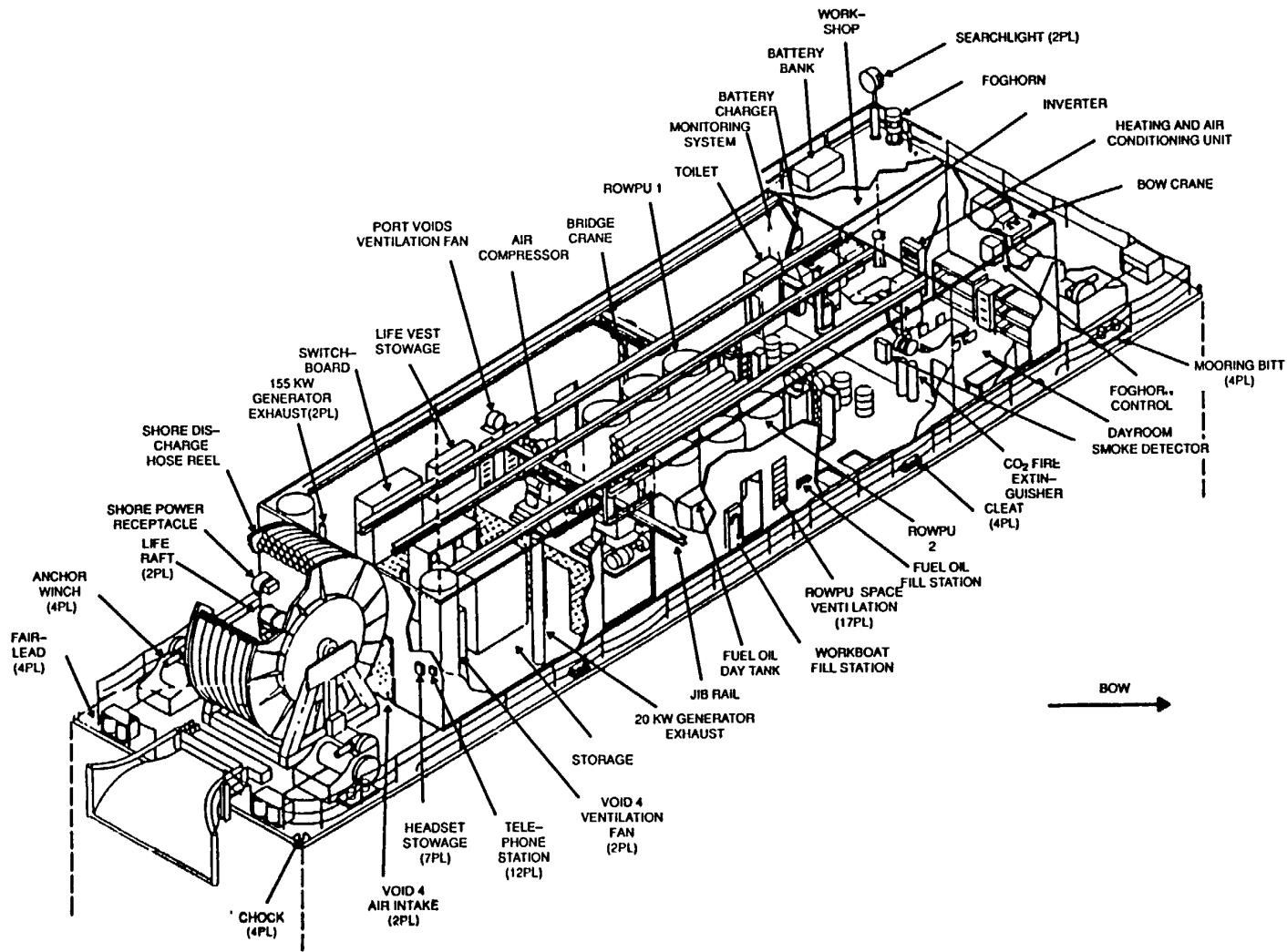

Figure 1-2. Major Components of ROWPU Barge Systems and Equipment - Deckhouse (Sheet 2 of 3)

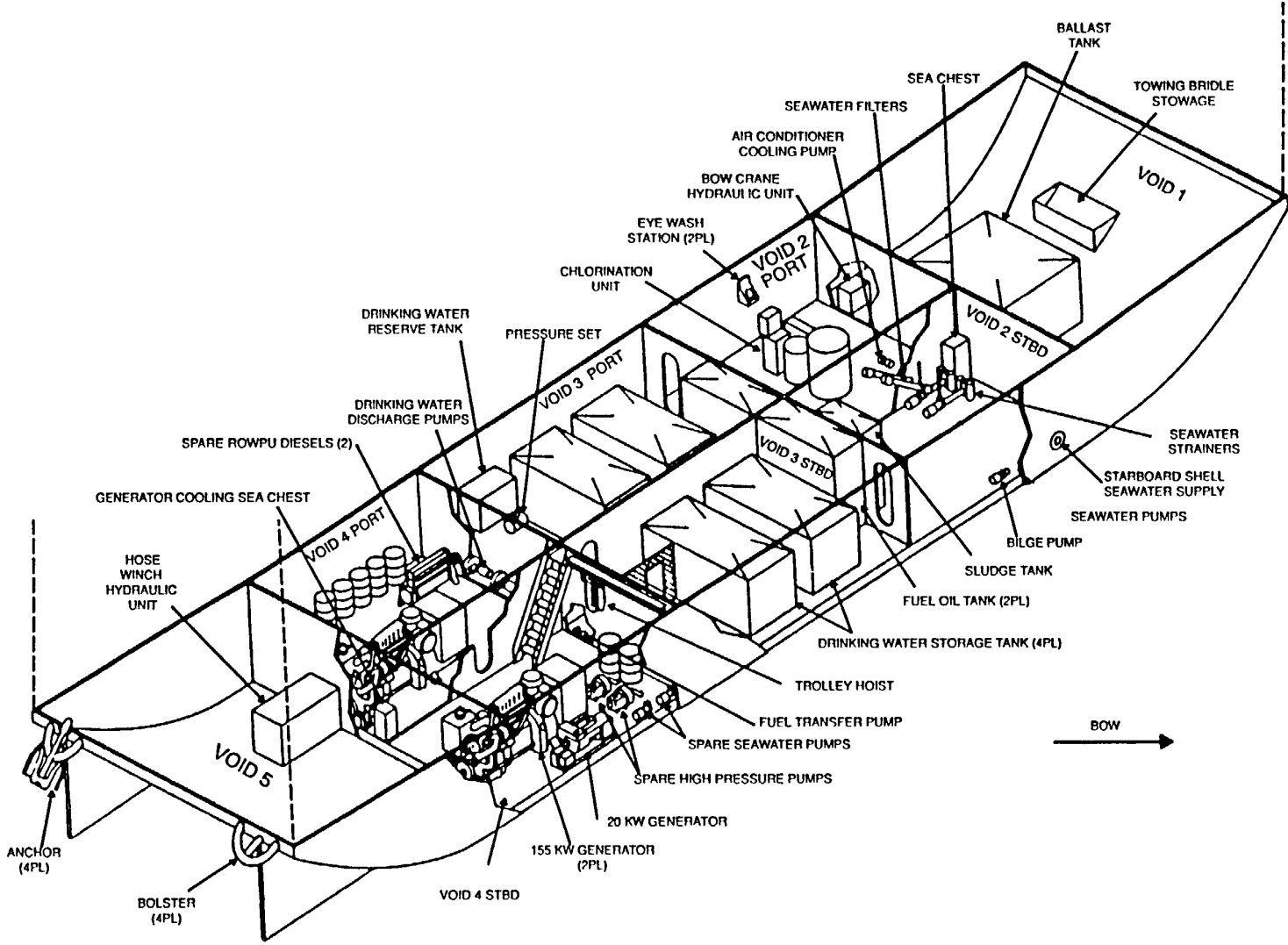

Figure 1-2. Major Components of ROWPU Barge Systems and Equipment - Voids (Sheet 3 of 3)

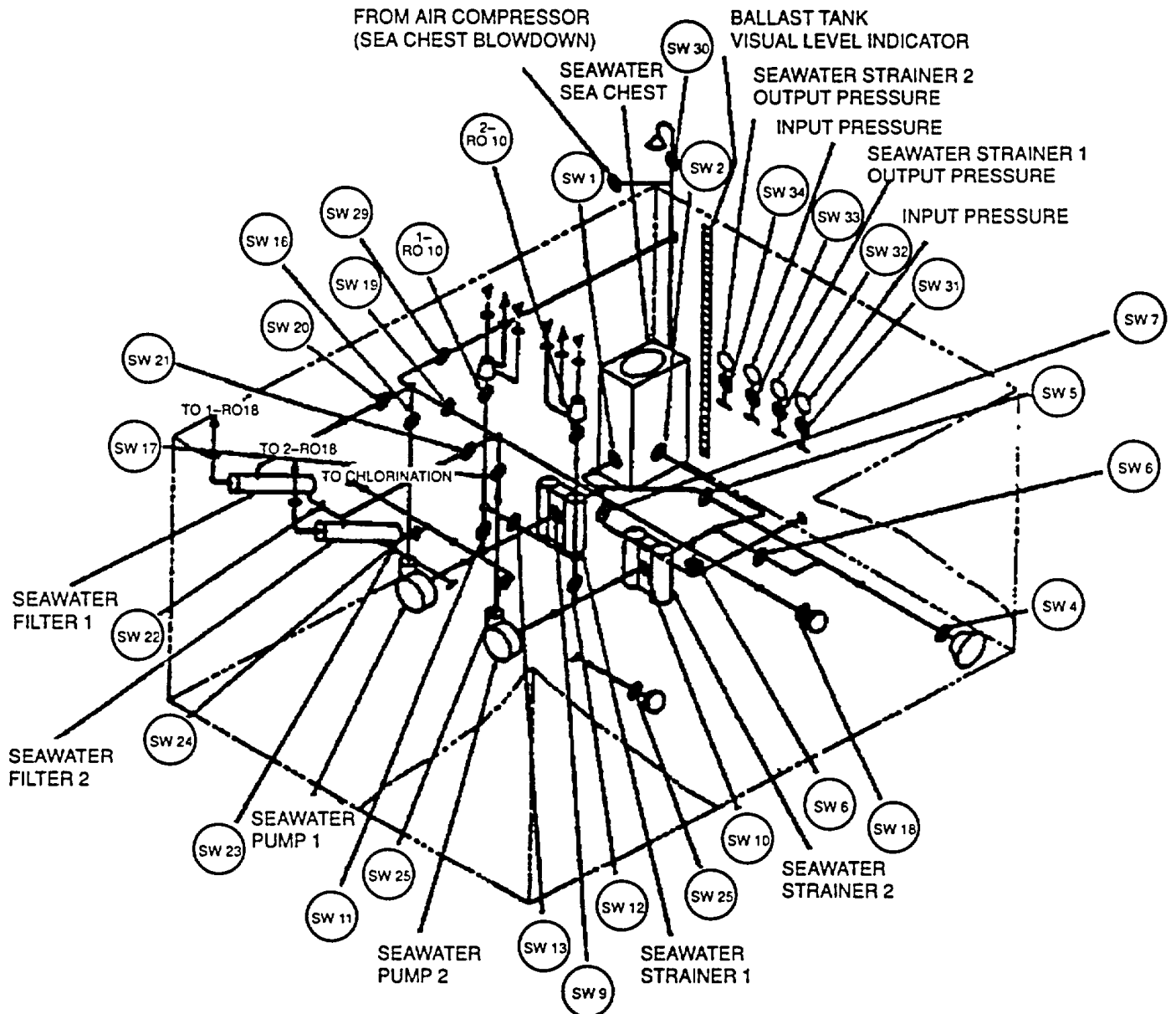

Figure 1-3. ROWPU and Ballast Seawater Supply

Table 1-1. Major Components of ROWPU and Ballast Seawater Supply

<u>Component</u>	<u>Function</u>	<u>Location</u>
Seachest	Supplies seawater for ROWPU processing, chlorination unit cooling, and heating and air conditioning unit cooling	Void 2 starboard
Seawater strainers 1 and 2	Remove foreign matter from seawater before water enters seawater pumps	Void 2 starboard
Seawater pumps 1 and 2	Draw seawater from seachest or shell penetration for processing in ROWPU's	Void 2 starboard
Seawater filters 1 and 2	Filter additional foreign matter from seawater before water enters ROWPU media filters	Void 2 starboard
Ballast tank	Stores seawater for trimming barge	Void 1
Ballast tank liquid level Indicator	Indicates seawater level in ballast tank	Void 2 starboard on forward bulkhead
Seawater pump OFF/	For operation of seawater pumps ON/START switches	ROWPU space on ROWPU 1 and 2 control stations
Seawater pump local control switches	Provide local operation of seawater pumps	Void 2 starboard on centerline bulkhead near pumps
Strainer 1 inlet pressure gauge	Indicates pressure in strainer 1 input line	Void 2 starboard
Strainer 1 outlet pressure gauge	Indicates pressure in strainer 1 output line	Void 2 starboard
Strainer 2 inlet pressure gauge	Indicates pressure in strainer 2 input line	Void 2 starboard
Strainer 2 outlet pressure gauge	Indicates pressure in strainer 2 output line	Void 2 starboard

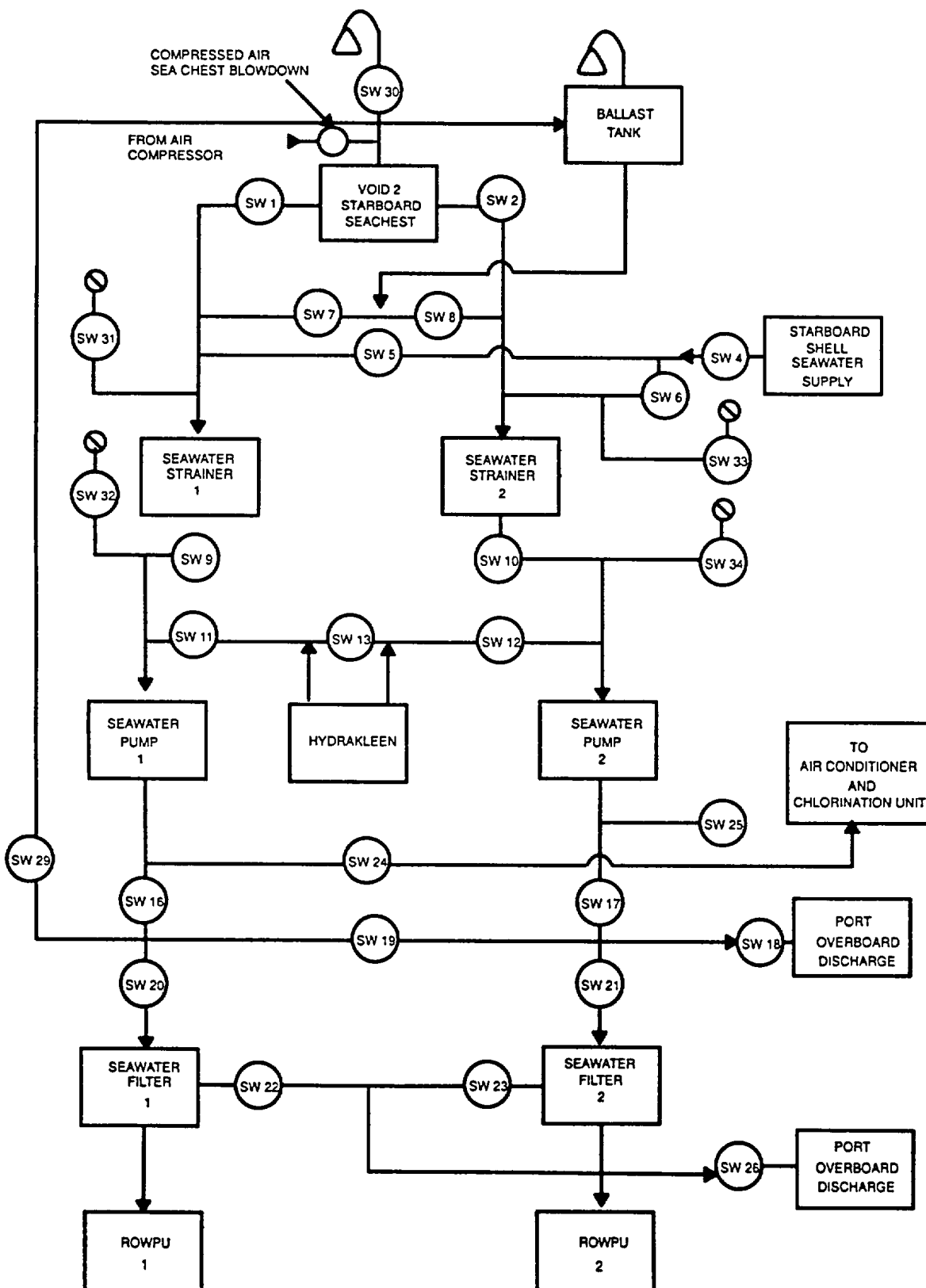

Figure 1-4. ROWPU and Ballast Seawater Supply Block Diagram

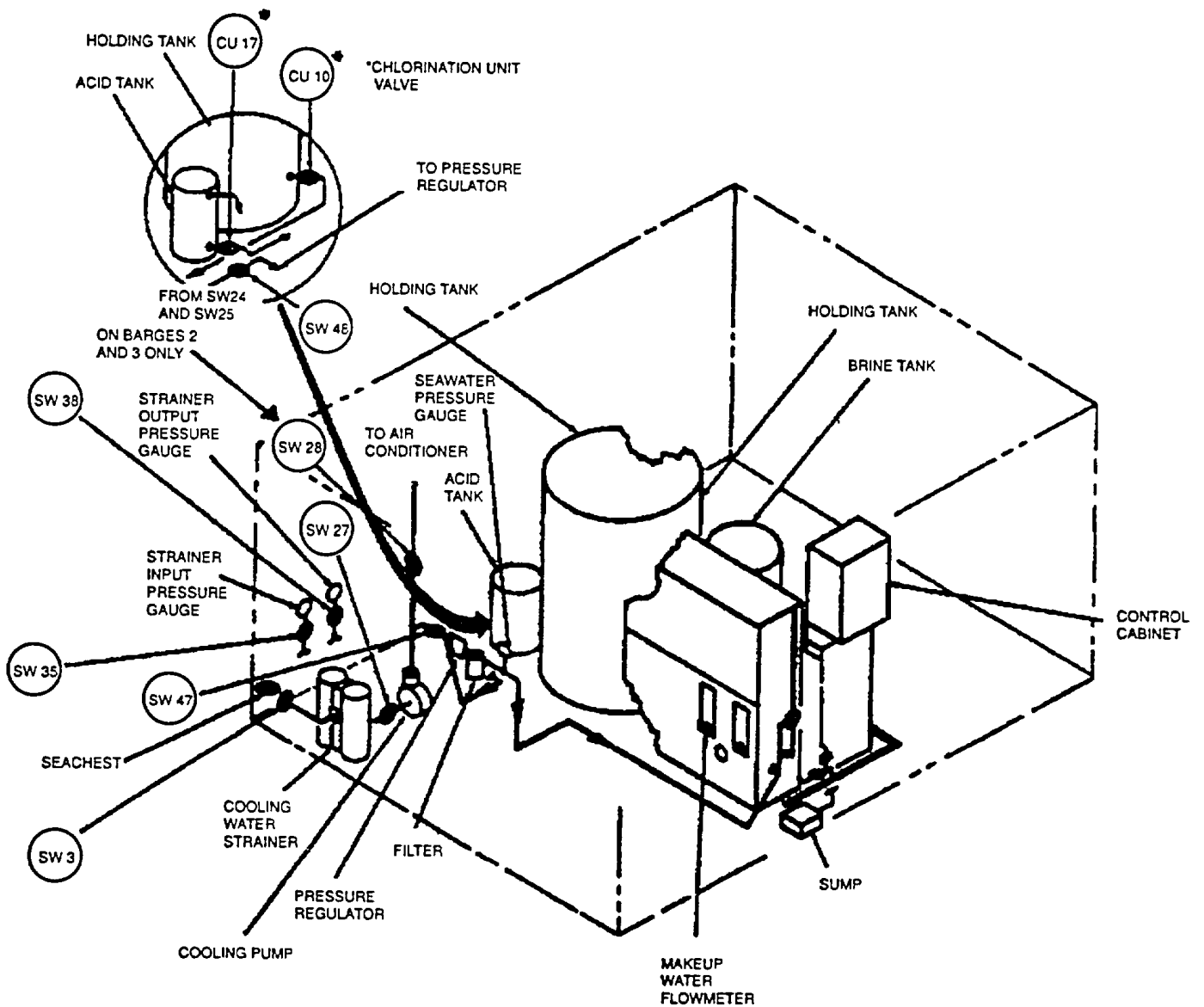

Figure 1-5. Air Conditioner Cooling Seawater and Chlorination Unit, Seawater Supply

Table 1-2. Major Components of Air Conditioner Cooling Seawater and Chlorination Unit
Seawater Supply

<u>Component</u>	<u>Function</u>	<u>Location</u>
Seawater strainer 3	Removes foreign matter from seawater before water enters air conditioning cooling pump	Void 2 port
Cooling pump	Draws seawater from seachest for cooling air conditioner and/or chlorination system	Void 2 port
Cooling pump motor controller	Allows manual operation of cooling pump	Void 2 port centerline bulkhead
Seawater pressure regulator	Controls pressure to chlorination unit	Void 2 port in seawater line
Seawater pressure gauge	Indicates seawater pressure to chlorination unit	Void 2 port in seawater line
Seawater filter 3	Filters seawater to chlorination unit	Void 2 port in seawater line
Strainer 3 inlet pressure gauge	Indicates pressure in strainer 3 input line	Void 2 port
Strainer 3 outlet pressure gauge	Indicates pressure in strainer 3 output line	Void 2 port

1-8 Capabilities. The three seawater supply sources are a forward seachest in void 2 starboard, a shell penetration in void 2 starboard, and an aft seachest in void 4 port. Seachest in void 2 starboard supplies sufficient seawater to ROWPU's for processing when barge is anchored in 15 or more feet of water. When anchored in 15 feet of water but not less than 10 feet, starboard shell intake can supply sufficient seawater to ROWPU's for processing. At all times, when barge is anchored or pierside, seachest in void 2 starboard can be used to supply seawater to the air conditioner and to the chlorination unit. The seachest in void 4 port also can be used to supply seawater for cooling the diesel generators whether the barge is anchored or pierside.

1-8.1 System capability definitions. System capability abbreviations used in this TM are defined as follows: gmp - gallons per minute, Hg - hydrargyrum (level of mercury such as used in a pressure gauge), Hz - Hertz, kW - kilowatt, ma - milliamperes, NPT - National Pipe Thread, ph - phase, psi - pounds per square inch, rpm - revolutions per minute, Vac - Volts alternating current.

1-9 Special limitations. Seawater system should not be operated in sea conditions exceeding Sea State 3. ROWPU feedwater must be kept free of chlorine, detergents, oil, and other contaminants. Water must be deep enough to ensure sand and other foreign matter are not taken into the system with the seawater.

1-10 Performance characteristics

- a. Cooling pump rating 22 gpm 100 ft
- b. Seawater pump rating 350 gpm 265 ft

1-11 Equipment specifications

- a. Pressure gauge (forward strainers)

Manufacturer	Ernest Gage Co
CAGEC	72256
Part no.	Figure 45
Type	Compound
Dial size	3 1/2 in. diameter
Range	15 psi./30 in. Hg.
Connection	Threaded
Quantity	6

- b. Seachest air escape valve

Manufacturer	Robert H. Wager Co., Inc.
CAGEC	79128
Part no.	Type 1600T
Type	Air escape
Size	2 in. nominal
Connection	Threaded
Material	Steel
Quantity	2

- c. Gate valve

Manufacturer	William Powell Co.
CAGEC	48422

Part no.	1414G
Size	6 in.
Rating	150 lb
Connection	Flanged
Material	Bronze
Quantity	7
d. Duplex strainer (seawater strainers 1 and 2)	
Manufacturer	Hayward Manufacturing Co.
CAGEC	73124
Part no.	Series no. 50
Size	6 in. nominal
Material	Bronze
Quantity	2
Basket:	
Mesh no.	20
Material	Brass
Quantity	4
e. Gate valve	
Manufacturer	William E. Williams Valve Corp.
CAGEC	79342
Part no.	IAIF
Size	4 in. nominal
Rating	150 lb
Connection	Flanged
Material	Bronze
Quantity	7
f. Pump (seawater pumps 1 and 2)	
Manufacturer	Hydranautics
CAGEC	52484
Model no.	TC-30
Type	Centrifugal
Rating	350 gpm 265 ft
Horsepower	40
Quantity	2
g. Swing check valve	
Manufacturer	Crane Co.
CAGEC	14959

	Part no.	4033
	Size	4 in. nominal
	Rating	250 lb
	Connection	Flanged
	Material	Bronze
	Quantity	2
h.	Check valve	
	Manufacturer	Milwaukee Valve Co.
	CAGEC	76364
	Part no.	1509
	Size	3/4 in. nominal
	Connection	Union end, silver braze
	Material	Bronze
	Quantity	1
i.	Gate valve	
	Manufacturer	William Powell Co.
	CAGEC	48422
	Part no.	Fig. 513
	Military specification	MIL-F-20042
	Size	1-1/2 in. nominal
	Rating	150 lb
	Connection	Flanged
	Material	Bronze
	Quantity	1
j.	Gate valve	
	Manufacturer	Milwaukee Valve Co.
	CAGEC	76364
	Part no.	Figure 1169
	Size	1 in. nominal
	Rating	150 lbs.
	Connection	Union end, silver braze
	Material	Bronze
	Quantity	2
k.	Pump (cooling)	
	Manufacturer	Aurora Pump
	CAGEC	04579
	Model no.	Series 110, MOD M4

Type	Centrifugal
Rating	22 gpm @ 100 ft
Motor	1750 rpm, 3 hp
Type	Duty Master AC Motor
Quantity	1
l. Globe valve	
NAVORDSYSCOM part no.	803-4384536
Size	1 in. nominal
Connection	Union end, silver braze
Material	Bronze
Quantity	2
m. Gate valve	
Manufacturer	William Powell Co.
CAGEC	48422
Part no.	Fig. 512
Size	1/4-in. nominal
Rating	150 lb
Connection	Female thread
Material	Bronze
Quantity	6
n. Check valve	
Manufacturer	Milwaukee Valve Co.
CAGEC	76364
Part no.	1509
Size	1/2 in. nominal
Rating	125 lbs.
Connection	Union end, silver braze
Material	Bronze
Quantity	1
o. Lakos separator (seawater filters 1 and 2)	
Manufacturer	Laval Separator Corp.
CAGEC	57266
Part no.	L-4042-FD-SC
Size	4 in. nominal, 22 1/2° profile
Rating	350 gpm
Quantity	2

- p. Gate valve
 - Manufacturer William Powell Co.
 - CAGEC 48422
 - Part no. Fig 515
 - Size 2-1/2 in. nominal
 - Rating 150 lbs
 - Connection Flanged
 - Material Bronze
 - Quantity 1
- q. Globe valve
 - Manufacturer Fairbanks Co.
 - CAGEC 21368
 - Part no. 090
 - Size 4 in. nominal
 - Rating 150 lb
 - Connection Flanged
 - Material Bronze
 - Quantity 6
- r. Globe valve
 - Manufacturer William Powell Co.
 - CAGEC 48422
 - Part no. Fig. 1531
 - Size 1-1/2 in. nominal
 - Rating 150 lb
 - Connection Flanged
 - Material Steel
 - Quantity 2
- s. Duplex strainer (seawater strainer 3)
 - Manufacturer Hayward Mfg. Co., Inc.
 - CAGEC 73124
 - Part no. Series no. 50
 - Size 1-1/2 in. nominal
 - Material Bronze
 - Quantity 1
 - Basket:
 - Mesh no. 20
 - Material Brass
 - Quantity 2

- t. Globe valve
 - Manufacturer Milwaukee Valve Co.
 - CAGEC 76364
 - Part no. 1590
 - Size 1-1/2 in. nominal
 - Rating 150 lbs.
 - Connection Union end, silver braze
 - Material Bronze
 - Quantity 1
- u. Liquid level indicator (ballast tank)
 - Manufacturer Transamerica DeLaval Inc.
 - CAGEC 04034
 - Part no. 86615 w/ROLI, 4-20MA
 - Type C
 - Indicating length 110 in
 - Connection 1 in. NPT
 - Quantity 1
- v. Gate valve
 - Manufacturer William Powell Co.
 - CAGEC 48422
 - Part no. Fig. 1414G
 - Size 4 in. nominal
 - Rating 150 lb
 - Connection Flanged
 - Material Bronze
 - Quantity 1
- w. Gate valve
 - Manufacturer William Powell Co.
 - CAGEC 48422
 - Part no. Fig. 2714
 - Size 2 in. nominal
 - Rating 150 lb
 - Connection Silver braze
 - Material Bronze
 - Quantity 2

- x. Gate valve
 - Manufacturer William Powell Co.
 - CAGEC 48422
 - Part no. Fig. 1414G
 - Size 3 in. nominal
 - Rating 150 lb
 - Connection Flanged
 - Material Bronze
 - Quantity 1
- y. Gate valve
 - Manufacturer William Powell Co.
 - CAGEC 48422
 - Part no. Fig. 2714
 - Size 1-1/4 in. nominal
 - Rating 150 lb
 - Connection Silver braze
 - Material Bronze
 - Quantity 1
- z. Ball valve
 - Manufacturer Ernst Gage Co.
 - CAGEC 72256
 - Part no. Cat. 710
 - Size 1/4 in. nominal
 - Connection Threaded
 - Material Brass
 - Quantity 2
- aa. Globe valve
 - Manufacturer William Powell Co.
 - CAGEC 48422
 - Part no. Fig. 150
 - Size 1-1/4 in. nominal
 - Rating 150 lb
 - Connection Silver braze
 - Material Bronze
 - Quantity 1

ab. Globe valve	
Manufacturer	William Powell Co.
CAGEC	48422
Part no.	Fig. 150
Size	2 in. nominal
Rating	150 lb
Connection	Silver braze
Material	Bronze
Quantity	2
ac. Air escape valve	
Manufacturer	Robert H. Wager Co.
CAGEC	79128
Part no.	Type 1600W
Size	3 in. nominal
Connection	Welded
Material	Steel
Quantity	1
ad. Duplex strainer (generator cooling strainer)	
Manufacturer	Hayward Mfg. Co. Inc.
CAGEC	73124
Part no.	Series no. 51
Size	4 in. nominal
Material	Bronze
Quantity	1
Basket:	
Mesh no.	20
Material	Brass
Quantity	2
ae. Pressure regulator	
Manufacturer	Ashcroft Gauge Co.
CAGEC	04198
Part no.	F-810A-02-V46
Type	Direct acting
Size	1/2 in. nominal
Material	Bronze
Quantity	1

- af. Temperature gauge (generator cooling)
 - Manufacturer Ernst Gage Co.
 - CAGEC 72256
 - Part no. Mod 758
 - Head size 3 in.
 - Range 0-250 degrees F.
 - Material Brass
 - Quantity 6
- ag. Swing check valve
 - Manufacturer William Powell Co.
 - CAGEC 48422
 - Part no. Figure 560Y
 - Size 2 in. nominal
 - Rating 150 lbs.
 - Connection Silver braze
 - Material Bronze
 - Quantity 2
- ah. Check valve
 - Military specification MIL-V-18436
 - Type Group A, type II, style C
 - Size 3 in. nominal
 - Connection Threaded
 - Material Bronze
 - Quantity 1
- ai. Gate valve
 - Specification ANS B16.34
 - Type A
 - Size 2 in. nominal
 - Rating 150 lbs.
 - Connection Butt weld
 - Material Steel
 - Quantity 1
- aj. Pressure gauge (generator cooling strainer)
 - Manufacturer Ernst Gage Co.
 - CAGEC 72256
 - Part no. Figure 45
 - Type Compound

Dial size	2 1/2 in. diameter
Range	5 psi/30 in. Hg
Connection	Threaded
Material	Brass
Quantity	2
ak. Swing check valve	
Manufacturer	William Powell Co.
CAGEC	48422
Part no.	Figure 560Y
Size	1 in. nominal
Rating	150 lbs.
Connection	Silver braze
Material	Bronze
Quantity	1
al. Filter	
Manufacturer	Brunswick Technetics Filterite subsidiary of Brunswick Corp.
Part no.	LM0IOS
Size	1/2 in. nominal w/20 micron filter tube
Material	Stainless steel
Quantity	1
am. Gate valve	
Manufactuer	Milwaukee Valve Co., Inc.
CAGEC	76364
Part no.	T-2884
Size	2 in. nominal
Rating	125 lbs.
Connection	Threaded
Material	Iron
Quantity	1
an. Zinc anode protector (forward seachest)	
Military specification	MIL-A-18001
Class	1
Type	ZSS
Size	6 in. X 3 in. X 1 1/4 in.
Material	Zinc
Quantity	2

ao. Zinc anode protector (aft seachest)	
Military specification	MIL-A-1 8001
Class	1
Type	ZSS
Weight	12 lbs.
Material	Zinc
Quantity	2
ap. Pressure gauge (chlorination unit)	
Manufacturer	Ashcroft Gauge Co.
CAGEC	04198
Part no.	1009
Type	Liquid filled
Dial size	3 1/2 in.
Range	0 - 100 psi
Connection	1/4 in. NPT
aq. Cooling pump motor controller	
Manufacturer	Square D Co.
	Milwaukee Manufacturing Plant
CAGEC	81487
Part no.	8538-SBA-21 -APT-440/110V-3ph-60Hz
Type	Non-reversing w/non-fusible disconnect switch
Rating	5 Hp, 440 Vac, 3 ph, 60 Hz
Quantity	1
Thermal unit	
Part no.	B6.90
Type	Melting alloy
Quantity	3
ar. Seawater pump START/STOP control switch	
Manufacturer	Square D Co.
	Milwaukee Manufacturing Plant
CAGEC	81487
Part no.	BW 240
Type	Class 9001, NEMA Type 4
Quantity	2

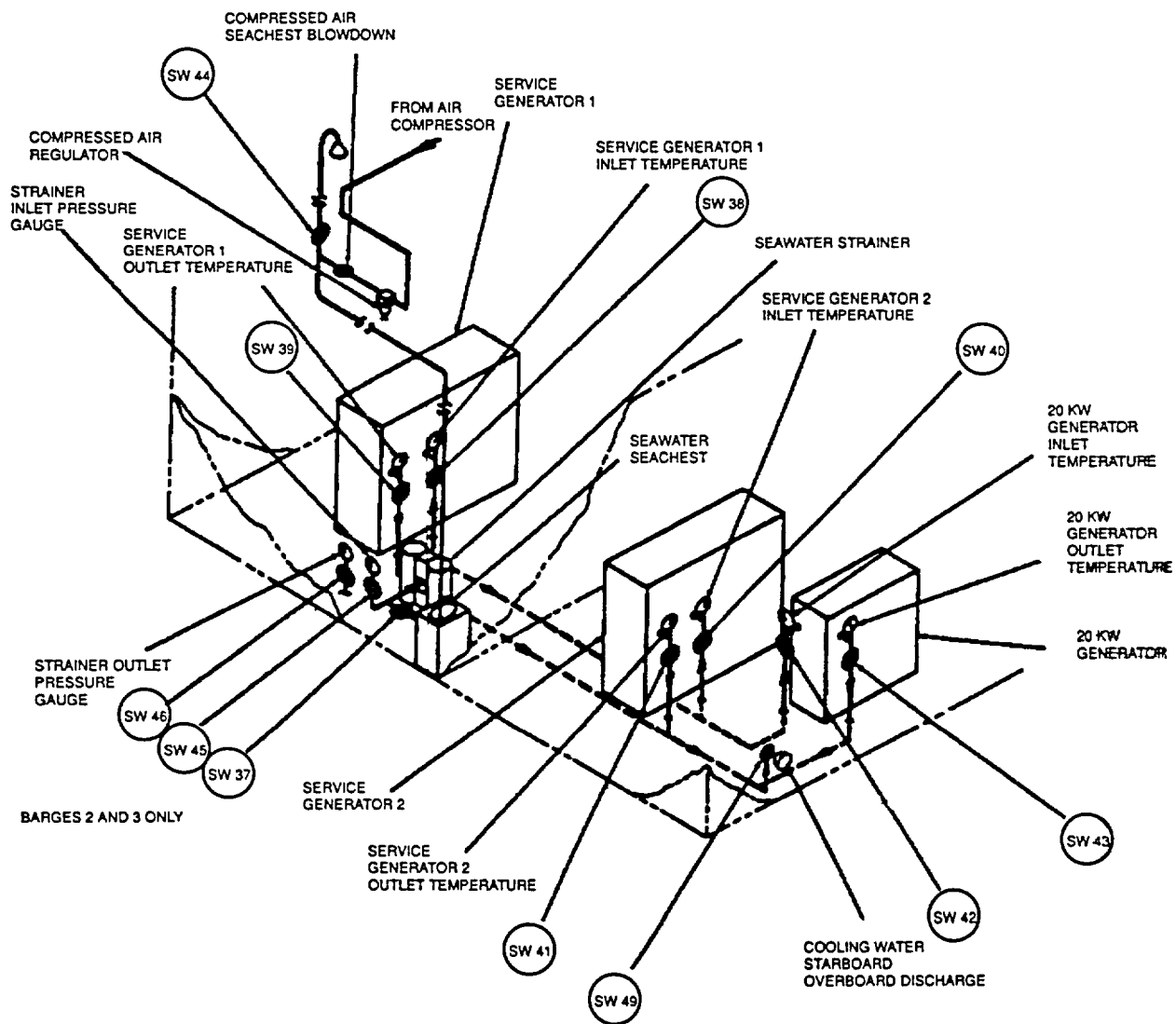

Figure 1-6. Diesel Engine Generator Cooling Seawater

Table 1-3. Major Components of Diesel Engine Generator Cooling Seawater

<u>Component</u>	<u>Function</u>	<u>Location</u>
Seachest	Supplies seawater for generator unit cooling	Void 4 port
Generator cooling strainer	Removes foreign matter from seawater before water enters generator cooling pump	Void 4 port
Cooling strainer inlet pressure gauge (Barges 2 and 3 only)	Indicates pressure in strainer input line	Void 4 port
Cooling strainer outlet pressure gauge (Barges 2 and 3 only)	Indicates pressure in strainer output line	Void 4 port
Inlet temperature gauge	Indicates temperature of cooling water entering each generator set	1 in void 4 port and 2 in void 4 starboard (one on each generator set)
Outlet temperature gauge	Indicates temperature of cooling water leaving each generator set	1 in void 4 port and 2 in void 4 starboard (one on each generator set except for the auxiliary generator on Barge 1)

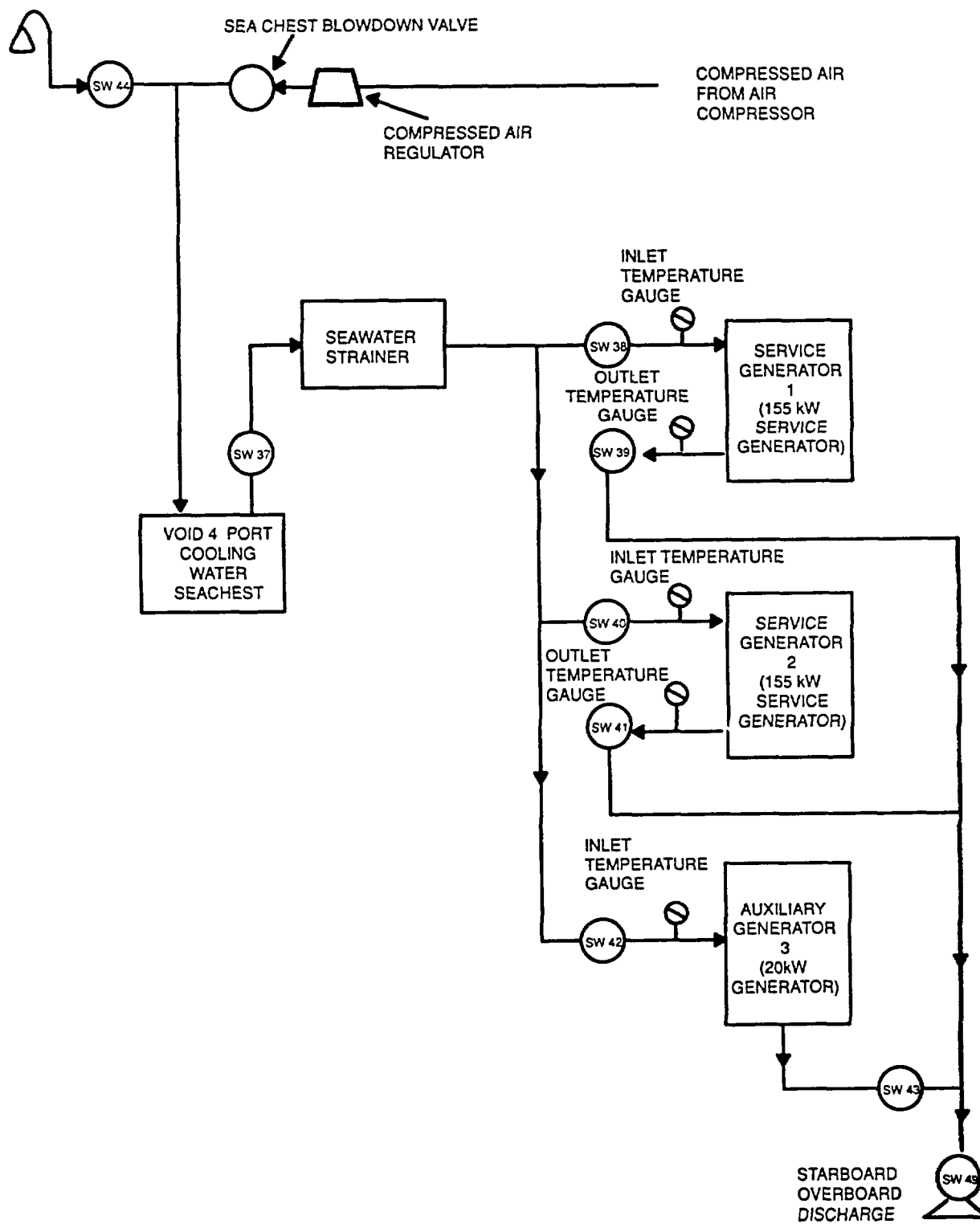

Figure 1-7. Diesel Engine Generator Cooling Seawater Block Diagram (Barge 1)

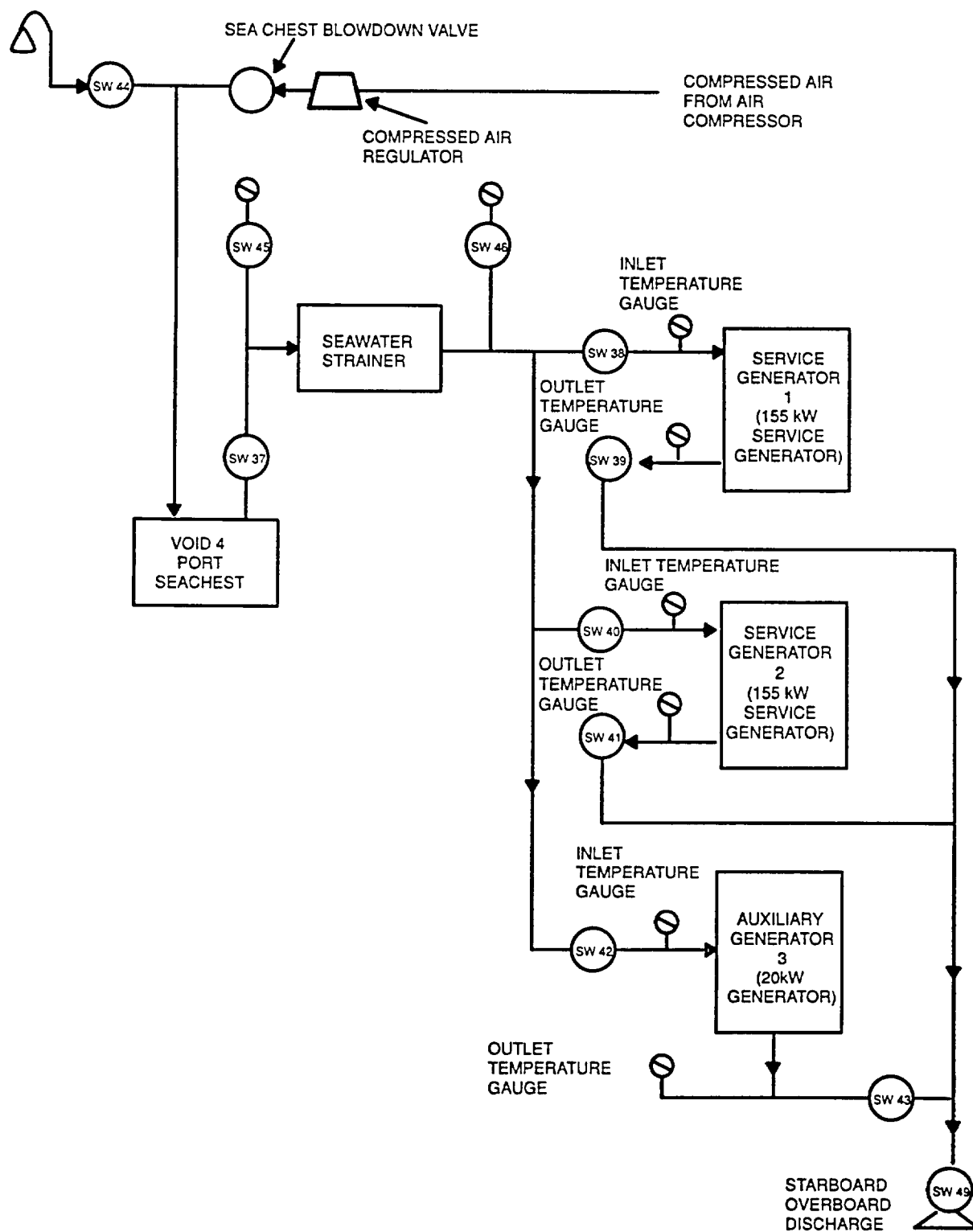

Figure 1-8. Diesel Engine Generator Cooling Seawater Block Diagram (Barges 2 and 3)

1-12 Items furnished

1-12.1 Components installed as part of seawater system are listed on parts lists of drawings referenced in Appendix A and in Components of End Item List in Appendix F of TM 55-1930-209-14&P-18.

1-12.2 Common and bulk items are listed in Expendable Supplies and Materials List in Appendix E of TM 55-1930-209-14&P-18.

1-12.3 Repair parts and special tools are listed in Repair Parts and Special Tools List in Appendix G of TM 55-1930-209-14&P-18.

1-13 Items required but not furnished. All required items are furnished.

1-14 Tools and test equipment. Use existing tools and equipment. A complete list of tools and test equipment is in Tools and Test Equipment List in Appendix D of TM 55-1930-209-14&P-18.

CHAPTER 2 DESCRIPTION OF OPERATION

2-1 ROWPU seawater supply. When barge is deployed in deep water (15 feet or more), seawater is obtained from the void 2 starboard seachest. When barge is deployed in shallow water (less than 15 but more than 10 feet), seawater is taken in through the void 2 starboard shell penetration. The seawater pumps draw the seawater through a strainer to remove foreign matter, and discharge the water through a seawater filter where additional foreign matter is removed. This filtered water then flows to the ROWPU's for processing.

2-2 Ballast seawater supply. Ballast seawater is used for altering the trim of the barge before discharging drinking water to shore or before towing. When barge is to be trimmed, seawater is drawn from void 2 starboard seachest or void 2 starboard shell penetration by seawater pump(s) and discharged into the ballast tank until desired trim is established. When ballast tank is to be drained, seawater is drawn from the tank by seawater pump(s) and discharged directly overboard through the overboard discharge in void 2 starboard.

2-3 Air conditioning unit seawater supply. When air conditioning unit is operating, a cooling pump draws seawater, through a strainer, from void 2 starboard seachest. Seawater is then discharged to air conditioning unit to cool the unit. After circulating through unit, the heated seawater is discharged directly overboard through overboard discharge in void 1 port.

2-4 Chlorination unit seawater supply. When ROWPU's are operating, seawater pumps supply strained seawater to the chlorination unit. When ROWPU's are not operating, strained seawater is supplied by the cooling pump. This seawater is used for priming the chlorination unit, for producing sodium hypochlorite, and for cooling. After circulating through the unit, the heated seawater is discharged directly overboard through the overboard discharge in void 1 port.

2-5 Diesel generators seawater supply. When any of the three diesel generators in voids 4 port and starboard are operating, cooling seawater is obtained from seachest in void 4 port. Seawater is drawn by a generator internal cooling pump through the generator cooling strainer before entering the pump. After circulating through the generators, the heated seawater is discharged directly through the overboard discharge in void 4 starboard.

CHAPTER 3 OPERATING INSTRUCTIONS

Section I. Operating controls and indicators

3-1 Operating controls and indicators. Operating controls and indicators are listed in Table 3-1 and shown in Figures 3-1 thru 3-3. Information on ROWPU and ballast seawater supply valves is in Table 3-2. Location of valves is shown in Figure 1-3. Information on air conditioning and chlorination cooling flow valves is in Table 3-2. Location of these valves is shown in Figure 1-5. Information on generator cooling flow valves is in Table 3-2. Location of these valves is shown in Figure 1-6.

Section II. Prestart procedures

3-2 Prestart procedures

- a. Check seawater system for damage prior to any operation.
- b. Perform before operation checks in paragraph 4-3.
- c. Provide power to ROWPU 1 and 2 control stations by closing (ON) switchboard circuit breakers P6 and P7.
- d. Provide power to cooling pump controller by closing (ON) power panel 1 circuit breaker 1 P5.

Section III. Operating procedures

3-3 Normal and alternate operating procedures

WARNING

Do not open seachest valves SW1, SW2, or SW3 unless valve SW30 is open to vent seachest to the atmosphere.

CAUTION

Seawater being supplied to ROWPU's must not be contaminated with oil, detergents, chlorine, or other foreign matter. Contaminated seawater could damage ROWPU membranes.

Water below barge seachests must be deep enough to ensure that sand and other foreign matter are not sucked into the system with the seawater.

NOTE

Deep water is defined as water 15 feet deep or more. Shallow water is defined as water less than 15 feet deep.

- a. Supplying seawater to ROWPU's is covered in paragraphs 3-3.1 and 3-3.2.
- b. Supplying seawater for chlorination unit is covered in paragraphs 3-3.3 and 3-3.4.
- c. Supplying seawater for filling and draining ballast tank is covered in paragraphs 3-3.5 and 3-3.6.
- d. Supplying seawater for cooling air conditioner and chlorination unit using air conditioning cooling pump is covered in paragraph 3-3.7.
- e. Supplying seawater for cooling diesel engine generators is covered in paragraph 3-3.8.
- f. Seachest blowdown is covered in paragraph 3-3.8.

Table 3-1. Operating Controls and Indicators

<u>Control/Indicator</u>	<u>Figure</u>	<u>Location</u>
Seawater pressure regulator	1-5	Void 2 port - near air conditioning pump
Seawater pressure gauge	1-5	Void 2 port - near cooling pump
Cooling pump motor controller	3-1	Void 2 port - starboard bulkhead
Seawater pumps 1 and 2 OFF/ON/START switches	3-1, 3-2	ROWPU space - ROWPU 1 and 2 control stations
Seawater pumps 1 and 2 START/STOP control switches	3-1	Void 2 starboard -centerline bulkhead
Ballast tank liquid level indicator	3-3	Void 2 starboard - forward bulkhead
Strainer 1 inlet pressure gauge	1-3	Void 2 starboard - forward bulkhead
Strainer 1 outlet pressure gauge	1-3	Void 2 starboard - forward bulkhead
Strainer 2 inlet pressure gauge	1-3	Void 2 starboard - forward bulkhead
Strainer 2 outlet pressure gauge	1-3	Void 2 starboard - forward bulkhead
Strainer 3 (cooling strainer) inlet pressure gauge	1-5	Void 2 port - centerline bulkhead
Strainer 3 (cooling strainer) outlet pressure gauge	1-5	Void 2 port - centerline bulkhead
Generator cooling strainer inlet pressure gauge	1-6	Void 4 port - aft bulkhead
Generator cooling strainer outlet pressure gauge	1-6	Void 4 port - aft bulkhead
Generator inlet temperature gauge	1-6	1 in void 4 port, 2 in void 4 starboard
Generator outlet temperature gauge	1-6	1 in void 4 port, 2 in void 4 starboard

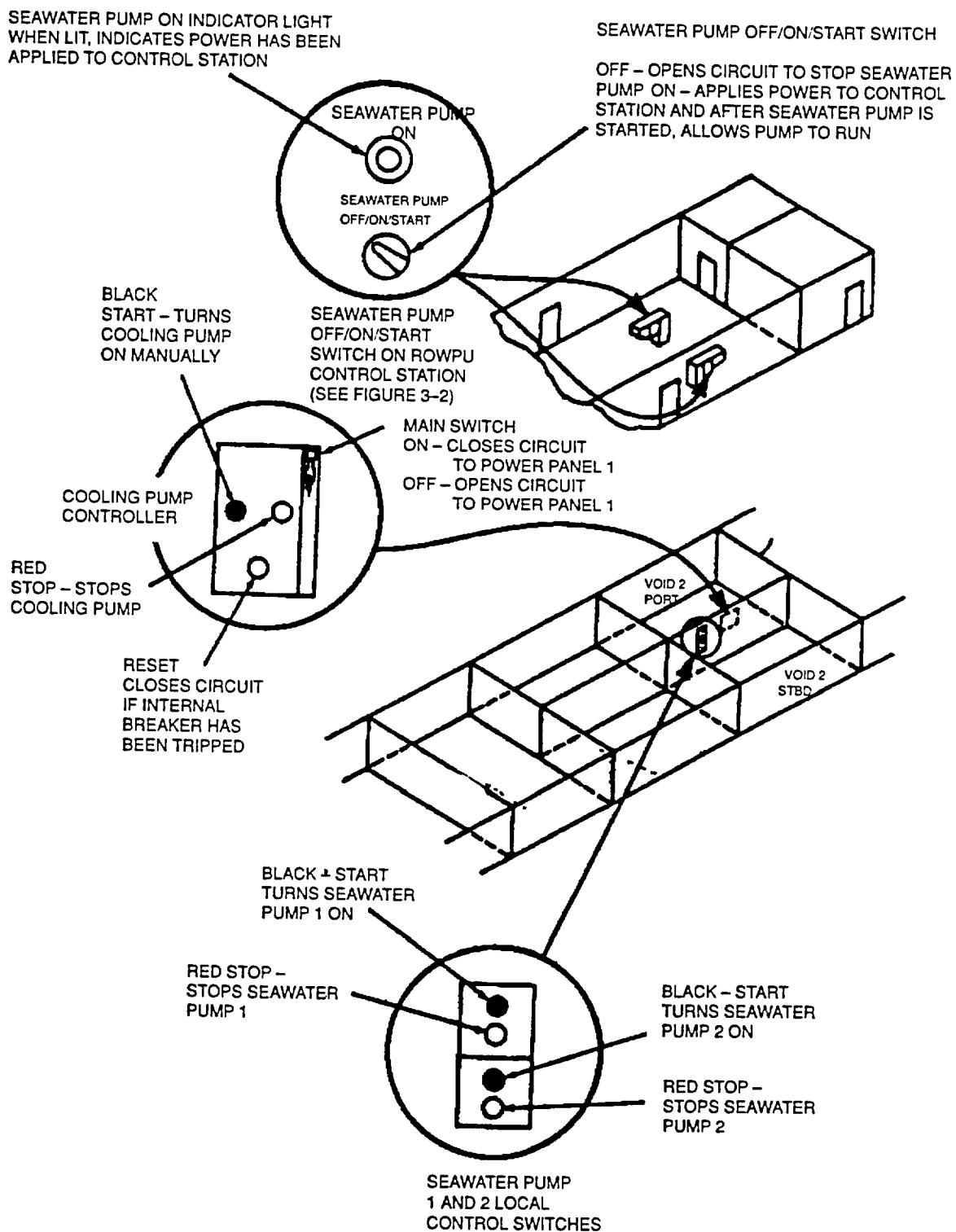

Figure 3-1. Seawater System's Electrical Controls

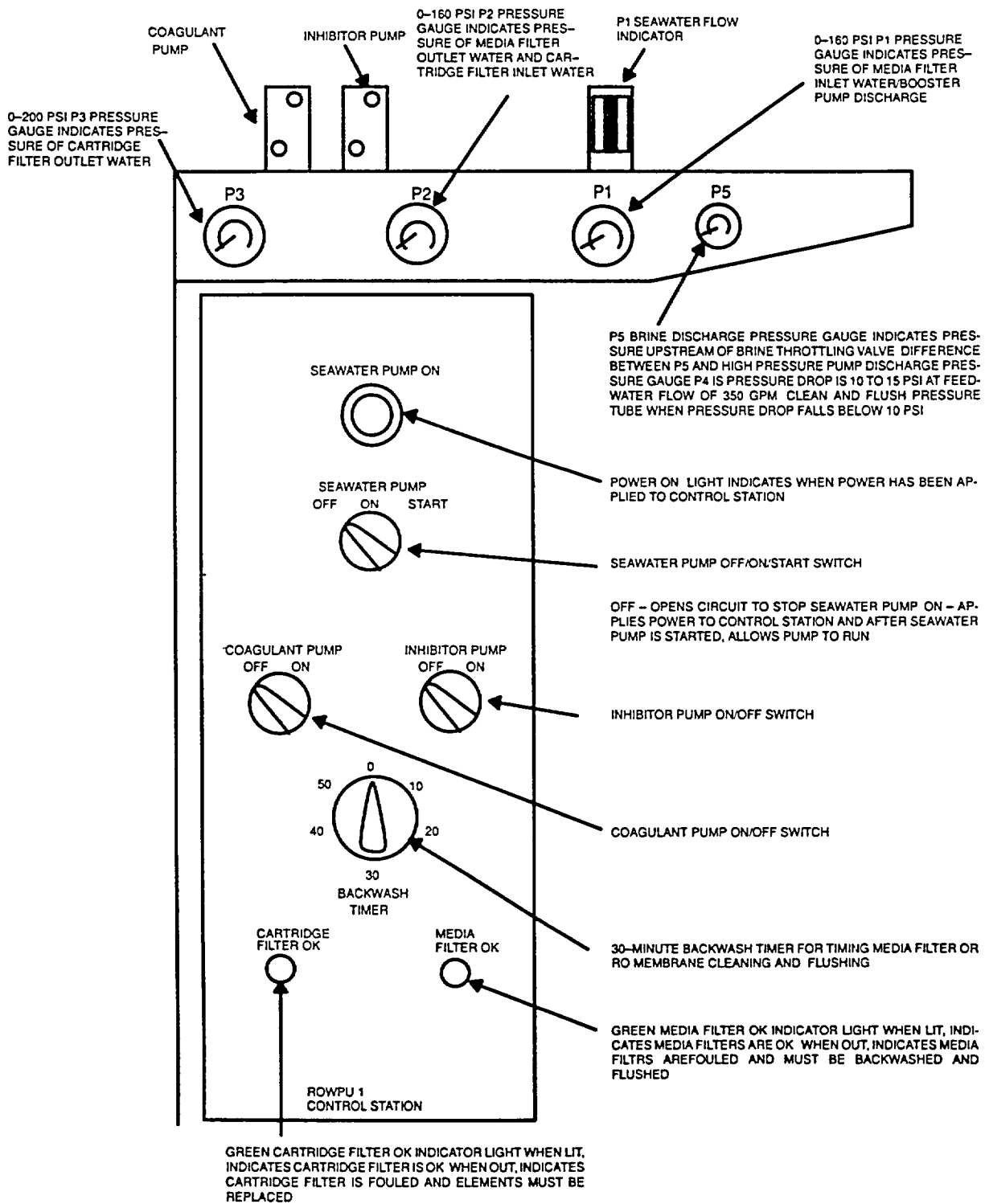

Figure 3-2. ROWPU Control Station (ROWPU 1 Station Shown)

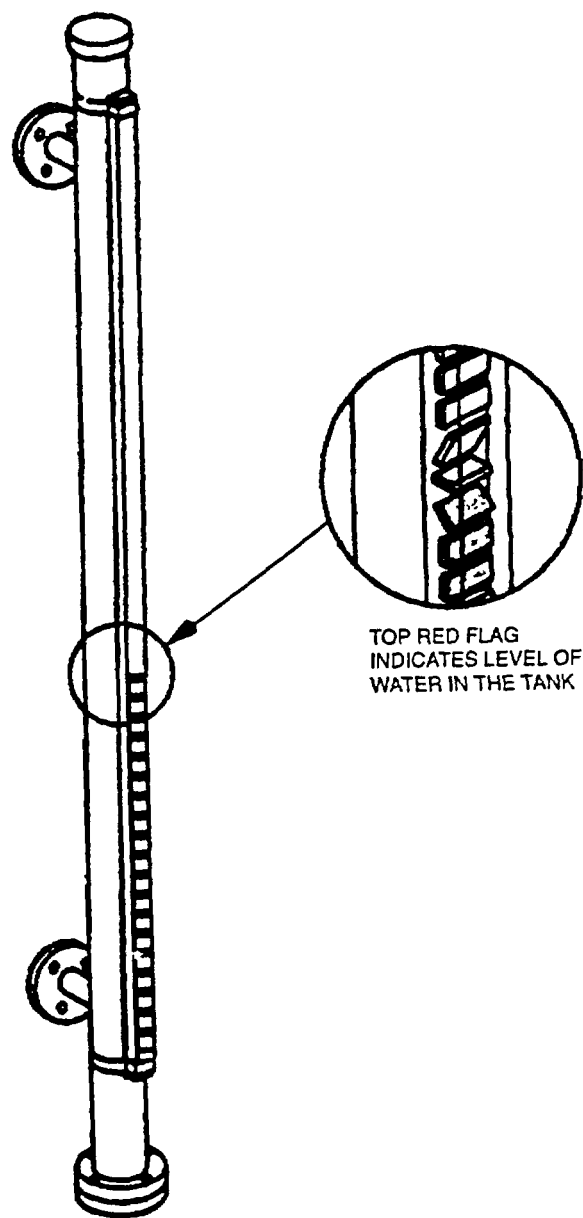

Figure 3-3. Ballast Tank Liquid Level Indicator

Table 3-2. Seawater System Valves

<u>Type</u>	<u>Figure 1-3 Callout</u>	<u>Location</u>	<u>Label Identification and Valve Function</u>
6-in gate valve	SW1	Void 2 starboard - In seawater supply line between seachest and seawater strainer	SEAWATER TO STRAINER 1: Allows flow from seachest to seawater strainer and isolates seachest from strainer
6-in gate valve	SW2	Void 2 starboard - In seawater supply line between seachest and strainer 2	SEAWATER TO STRAINER 2: Allows flow from seachest to seawater strainer and isolates seachest from strainer
1 1/2-in gate valve	SW3	Void 2 port - In seawater supply line between seachest and cooling water strainer	SEAWATER TO STRAINER 3: Allows flow from seachest to strainer and isolates seachest from strainer
6-in gate valve	SW4	Void 2 starboard - In seawater supply line from starboard shell	STARBOARD SEAWATER SUPPLY TO STRAINERS:- Allows seawater to be supplied from starboard shell to seawater strainers
6-in gate valve	SW5	Void 2 starboard - In seawater supply line from starboard shell	STRAINER 1 INPUT: Allows seawater to be supplied from starboard shell and isolates strainer 1
6-in gate valve	SW6	Void 2 starboard - In seawater supply line from starboard shell	STRAINER 2 INPUT: Allows seawater to be supplied from starboard shell and isolates strainer 2
4-in gate valve	SW7	Void 2 starboard - In ballast tank drain line on suction side of seawater pump 1	BALLAST DRAIN TO STRAINER 1: Allows seawater to drain from tank to seawater pump 1 and isolates ballast tank
4-in gate valve	SW8	Void 2 starboard - In ballast tank drain line on suction side of seawater pump 2	BALLAST DRAIN TO STRAINER 2: Allows seawater to drain from tank to seawater pump 2 and isolates ballast tank
6-in gate valve	SW9	Void 2 starboard - In seawater pump 1 supply line	STRAINER 1 TO SEAWATER PUMP: Allows seawater being obtained from seachest or starboard shell seawater supply to flow to seawater pump 1 and isolates seawater strainer from pump 1
6-in gate valve	SW10	Void 2 starboard - In seawater pump 2 supply line	STRAINER 2 TO SEAWATER PUMP: Allows seawater being obtained from seachest or starboard shell seawater supply to flow to seawater pump 2 and isolates seawater strainer from pump 2

Table 3-2. Seawater System Valves (continued)

<u>Type</u>	<u>Figure 1-3 Callout</u>	<u>Location</u>	<u>Label Identification and Valve Function</u>
4-in gate valve	SW11	Void 2 starboard - In ROWPU membrane cleaning supply crossover line	SEAWATER PUMP 1 SUPPLY: Allows flow from ROWPU membrane cleaning supply to seawater pump 1
4-in gate valve	SW12	Void 2 starboard - In ROWPU membrane cleaning supply crossover line	SEAWATER PUMP 2 SUPPLY: Allows flow from ROWPU membrane cleaning supply to seawater pump 2
4-in gate valve	SW13	Void 2 starboard - In ROWPU membrane cleaning supply crossover line	SEAWATER PUMP SUPPLY CROSSOVER: Isolates seawater pump 1 supply from seawater pump 2 supply
Valves SW14 and SW15 were eliminated in redesign.			
4-in globe valve	SW16	Void 2 starboard - In seawater pump 1 discharge line	SEAWATER PUMP 1 TO SEAWATER FILTER: Allows seawater to flow from seawater pump 1 to ROWPU's via filter and isolates pump
4-in globe valve	SW17	Void 2 starboard - In seawater pump 2 discharge line	SEAWATER PUMP 2 TO SEAWATER FILTER: Allows seawater to flow from seawater pump 2 to ROWPU's via filter and isolates pump
4-in globe valve	SW18	Void 2 starboard - In ballast tank drain line on discharge side of seawater pumps on starboard shell	OVERBOARD DISCHARGE: Allows seawater being drained from ballast tank to be discharged by seawater pumps directly overboard
4-in gate valve	SW19	Void 2 starboard - In seawater pump discharge crossover line	SEAWATER PUMP DISCHARGE CROSSOVER: Isolates seawater pump 1 discharge from seawater pump 2 discharge
4-in globe valve	SW20	Void 2 starboard - In seawater pump 1 discharge line	SEAWATER FILTER 1 IN: Allows seawater to flow from seawater pump 1 to ROWPU 1 via filter and isolates filter
4-in globe valve	SW21	Void 2 starboard - In seawater pump 2 discharge line	SEAWATER FILTER 2 IN: Allows seawater to flow from seawater pump 2 to ROWPU 2 via filter and isolates filter
1 1/2-in throttle valve	SW22	Void 2 starboard - In seawater filter 1 drain line	SEAWATER FILTER 1 DRAIN: Allows removal of solids from seawater filter 1
1 1/2-in throttle valve	SW23	Void 2 starboard - In seawater filter 2 drain line	SEAWATER FILTER 2 DRAIN: Allows removal of solids from seawater filter 2

Table 3-2. Seawater System Valves (continued)

<u>Type</u>	<u>Figure 1-3 Callout</u>	<u>Location</u>	<u>Label Identification and Valve Function</u>
1-in gate valve	SW24	Void 2 starboard - In seawater supply line between seawater pump 1 and valve SW48	SEAWATER PUMP 1 TO CHLORINATION UNIT: Allows seawater from seawater pump 1 to be supplied to chlorination system
1-in gate valve	SW25	Void 2 starboard - In seawater supply line between seawater pump 2 and valve SW48	SEAWATER PUMP 2 TO CHLORINATION UNIT: Allows seawater from seawater pump 2 to be supplied to chlorination system
2 1/2-in gate valve	SW26	Void 2 starboard - In seawater filter drain line on starboard shell	SEAWATER FILTER OVERBOARD DISCHARGE: Allows seawater from filter drain lines to discharge directly overboard
1 1/2-in gate valve	SW27	Void 2 port - In cooling pump supply line	STRAINER 3 TO AIR CONDITIONER COOLING PUMP: Allows seawater to flow to cooling pump and isolates pump from strainer 3
1-in globe valve	SW28 (Barges 2 and 3 only)	Void 2 port- In cooling seawater inlet line	AIR CONDITIONER COOLING WATER: Allows seawater from cooling pump to flow to air conditioning cooling coils and isolates pump from air conditioning unit
4-in globe valve	SW29	Void 2 starboard - In ballast tank fill line on discharge side of seawater pump 1	SEAWATER PUMPS TO BALLAST TANK: Allows seawater to flow from seawater pumps into ballast tank and isolates ballast tank
2-in gate valve	SW30	Deckhouse workshop -In seachest vent line	SEAWATER SEACHEST VENT: Allows seachest venting
1/4-in gate valve	SW31	Void 2 starboard - In seawater supply line on input side of strainer 1	STRAINER 1 PRESSURE IN: Allows pressure reading on supply side of strainer 1
1/4-in gate valve	SW32	Void 2 starboard - In seawater supply line on discharge side of strainer 1	STRAINER 1 PRESSURE OUT: Allows pressure reading on discharge side of strainer 1
1/4-in gate valve	SW33	Void 2 starboard - In seawater supply line on input side of strainer 2	STRAINER 2 PRESSURE IN: Allows pressure reading on supply side of strainer 2
1/4-in gate valve	SW34	Void 2 starboard - In seawater supply line on discharge side of strainer 2	STRAINER 2 PRESSURE OUT: Allows pressure reading on discharge side of strainer 2

Table 3-2. Seawater System Valves (continued)

<u>Type:</u>	<u>Figure 1-3 Callout</u>	<u>Location</u>	<u>Label Identification and Valve Function</u>
1/4-in gate valve	SW35	Void 2 port - In sea-water supply line between seachest and cooling water strainer	COOLING WATER STRAINER PRESSURE IN: Allows pressure reading on supply side of cooling water strainer
1/4-in gate valve	SW36	Void 2 port - In seawater supply line between cooling water strainer and cooling pump	COOLING WATER STRAINER PRESSURE OUT: Allows pressure reading on discharge side of cooling water strainer
4-in gate valve	SW37	Void 4 port - In sea-water supply line between seachest and strainer	GENERATOR COOLING SEACHEST TO STRAINER: Allows flow from seachest to strainer and isolates strainer
2-in gate valve	SW38	Void 4 port - On input side of generator 1 cooling line	STRAINER TO GENERATOR 1 COOLING: Allows cooling flow to generator 1 and isolates strainer
2-in globe valve	SW39	Void 4 port - On discharge side of generator cooling line	GENERATOR 1 COOLING TO OVERBOARD: Allows cooling flow from generator and isolates generator from overboard discharge
2-in gate valve	SW40	Void 4 starboard - On input side of generator 2 cooling line	STRAINER TO GENERATOR 2 COOLING: Allows cooling flow to generator 2 and isolates strainer
2-in globe valve	SW41	Void 4 starboard - On discharge side of generator cooling line	GENERATOR 2 COOLING TO OVERBOARD: Allows cooling flow from generator and isolates generator from overboard discharge
1 1/4-in gate valve	SW42	Void 4 starboard - On input side of 20 kW generator cooling	STRAINER TO 20 kW GENERATOR COOLING: Allows cooling flow to 20 kW generator and isolates strainer
1 1/4-in globe valve	SW43	Void 4 starboard - On discharge side of 20 kW generator cooling line	20 kW GENERATOR COOLING TO OVERBOARD: Allows cooling flow from generator and isolates generator from overboard discharge
2-in gate valve	SW44	ROWPU space - in cooling water seachest vent line	GENERATOR COOLING SEACHEST VENT: Allows seachest venting

Table 3-2. Seawater System Valves (continued)

Type	Figure 1-3 Callout	Location	Label Identification and Valve Function
1/4-in ball valve	SW45 (Barges 2 and 3 only)	Void 4 port - In seawater supply line between seachest and strainer	GENERATOR COOLING STRAINER PRESSURE IN: Allows pressure reading on supply side of cooling water
1/4-in ball valve	SW46 (Barges 2 and 3 only)	Void 4 port - In seawater cooling line on discharge side of strainer	GENERATOR COOLING STRAINER PRESSURE OUT: Allows pressure reading on discharge side of strainer
1-in gate valve	SW47	Void 2 port - In cooling pump line discharge	AIR CONDITIONING COOLING PUMP TO CHLORINATION UNIT: Allows seawater to flow to chlorination unit from cooling pump and isolates pump
1/2-in globe valve	SW48	Void 2 port - In seawater supply line between seawater pumps and chlorination unit pressure regulator conditioning system	SEAWATER PUMPS TO CHLORINATION UNIT: Allows seawater from seawater pumps to enter chlorination and air
3-in gate valve	SW49	Void 4 starboard - In diesel generator cooling line on starboard shell	GENERATOR COOLING OVERBOARD DISCHARGE: Allows seawater from generators to be discharged directly overboard

3-3.1 Supplying seawater to ROWPU's from seachest (deep water) using seawater pump(s) 1 and/or 2.

NOTE

See Figures 1-3 thru 1-1 for seawater valve locations.

3-3.1.1 Normal procedures

- a. Perform before operation checks in paragraph 4-3.
- b. If seawater is to be supplied to chlorination unit when cooling pump is not being operated, set seawater pressure regulator to 10 psi and open seawater valve SW48 in void 2 port. To supply cooling water to air conditioner, open seawater valves SW47 and SW28 (Barges 2 and 3 only).
- c. Close seawater valves SW4 thru SW8, SW11 thru SW13, SW18, SW19, SW22, SW23, SW26, SW27, and SW29. Open seawater valves SW30 thru SW34.

d. Open or close seawater valves as follows:

o = open x = closed - = not affected

Seawater (SW) valve no.:

Supplying seawater to:	1	2	3	9	10	16	17	20	21	24	25
Both ROWPU units	o	o	-	o	o	o	o	o	o	o	o
ROWPU 1 only	o	x	-	o	-	o	-	o	o	-	x
ROWPU 2 only	x	o	-	o	-	o	-	o	o	x	o

NOTE

In addition to the following procedures, seawater pumps can be started and stopped at local control switches in void 2 starboard.

- e. Make sure switchboard circuit breakers P6 and P7 are closed (ON).
- f. To supply seawater to both ROWPU's, start seawater pumps 1 and 2 by turning seawater pump OFF/ON/START switch to ON at ROWPU 1 and ROWPU 2 control stations. To supply seawater to only ROWPU, turn appropriate switch to ON.
- g. Start ROWPU system according to TM 55-1930-209-14 & P-3.
- h. While operating, perform during operation checks in paragraph 4-3.

3-3.1.2 Alternate procedures

NOTE

Alternate procedures may be followed when normal procedures cannot be used due to maintenance or component breakdown. See Figures 1-3 thru 1-1 for seawater valve locations.

- a. Perform steps a and b in paragraph 3-3.1.1.
- b. Close seawater valves SW7, SW8, SW13, SW18, SW26, SW27, and SW29.
- c. Open or close seawater valves as follows:

o = open x = closed - = not affected

SW valve no.:

Supplying seawater to:	1	2	3	9	10	16	17	20	21	24	25
ROWPU 1 from SW pump 2	o	o	-	o	o	o	o	o	o	o	o
ROWPU 2 from SW pump 1	o	x	-	o	-	o	-	o	o	-	x

- d. Perform steps e thru h in paragraph 3-3.1.1.

3-3.2 Supplying seawater to ROWPU's from starboard shell penetration (shallow water) using seawater pump(s) 1 and/or 2

3-3.2.1 Normal procedures

NOTE

See Figures 1-3 thru 1-1 for seawater valve locations.

- a. Perform before operation checks in paragraph 3-3.1.1.
- b. If seawater is to be supplied to chlorination unit when cooling pump is not being operated, set seawater pressure regulator to 10 psi and open seawater valve SW48 in void 2 port. To supply cooling water to air conditioner, open seawater valves SW47 and SW28 (Barges 2 and 3 only).
- c. Close seawater valves SW7, SW8, SW18, SW26, SW27, and SW29 in void 2. Open seawater valves SW30 thru SW34.
- d. Open or close seawater valves as follows:

	o = open		x = closed				- = not affected										
	SW valve no.:																
<u>Supplying seawater to:</u>	1	2	5	6	9	10	11	12	16	17	19	20	21	22	23	24	25
Both ROWPU units	x	x	o	o	o	o	x	x	o	o	x	o	o	x	x	o	o
ROWPU 1 only	x	x	o	x	o	-	x	-	o	-	x	o	-	x	-	o	x
ROWPU 2 only	x	x	x	o	-	o	-	x	-	o	x	x	o	-	x	x	o

- e. Open seawater valve SW4 in void 2 near starboard shell.

NOTE

In addition to the following procedures, seawater pumps can be started and stopped at local control switches in void 2 starboard.

- f. Make sure switchboard circuit breakers P6 and P7 are closed (ON).
- g. To supply seawater to both ROWPU's, start seawater pumps 1 and 2 by turning seawater pump OFF/ON/START switch to ON at ROWPU 1 and ROWPU 2 control stations. To supply seawater to only one ROWPU, turn appropriate switch to ON.
- h. Start ROWPU system according to TM 55-1930-209-14 & P-3.
- i. While system is operating, perform during operation checks.

3-3.2.2 Alternate procedures

NOTE

Alternate procedures may be followed when normal procedures cannot be used due to maintenance or component breakdown. See Figures 1-3 thru 1-1 for seawater valve locations.

- a. Perform steps a and b in paragraph 3-3.2.1.
- b. Open or close seawater valves as follows:

o = open x = closed - = not affected

SW valve no.:

<u>Supplying seawater to:</u>	1	2	5	6	9	10	11	12	16	17	19	20	21	22	23	24	25
ROWPU 1 from SW pump 2	x	x	x	o	-	o	x	x	o	o	o	x	x	x	-	x	o
ROWPU 2 from SW pump 1	x	x	o	x	o	-	x	-	o	x	o	x	o	-	x	o	x

NOTE

In addition to the following procedures, seawater pumps 1 and 2 can be started and stopped at local control switches in void 2 starboard.

- c. Perform steps e thru i in paragraph 3-3.2.1.

3-3.3 Supplying seawater from seawater pumps to chlorination and air conditioning units

NOTE

The following procedures assume that seawater pump(s) are operating. If these pumps are not operating and seawater is required for chlorination unit, follow procedures in paragraph 3-3.4.

NOTE

See Figures 1-3 thru 1-1 for seawater valve locations.

- a. Perform before operation checks in paragraph 4-3.
- b. To obtain seawater from seawater pump(s) for chlorination and air conditioning units, open the following valves:
 - (1) Valve SW24 in void 2 port for seawater pump 1,
 - (2) Valve SW25 in void 2 port for seawater pump 2,
 - (3) Valves SW24 and SW25 for both seawater pumps.
- c. Open valve SW48 in void 2 port.
- d. If seawater is required for chlorination unit only, close valve SW47 in void 2 port.
- e. If seawater is required for both chlorination and air conditioning units, open valves SW47 and SW28 in void 2 port. Make sure valve SW27 in void 2 port is closed.
- f. If seawater is required for air conditioning unit only, open valves SW47 and SW28. Cooling seawater will be supplied to air conditioner as well as to chlorination unit, but cooling water in chlorination unit will simply circulate through cooling portion of unit and pass overboard through port discharge.
- g. While operating, perform during operation checks.

3-3.4 Supplying seawater from cooling pump to air conditioning and chlorination units

NOTE

See Figures 1-5 thru 1-1 for seawater valve locations.

- a. Perform before operation checks in paragraph 4-3.
- b. Close seawater valve SW48 to turn off seawater from nonoperating seawater pumps in void 2 starboard.
- c. Open seawater valves SW3 and SW27 in void 2 port to supply seawater to cooling pump.
- d. Open seawater valves SW35 and SW36 in void 2 port to monitor pressure differences between input and output of seawater strainer 3 supplying seawater to cooling pump.
- e. To supply seawater to chlorination unit and air conditioner, open seawater valves SW28 (Barges 2 and 3 only) and SW47.
- f. To supply seawater to air conditioner only, open seawater valve SW28 (Barges 2 and 3 only) and close SW47.
- g. To supply seawater to chlorination unit only, open seawater valve SW47 and close SW28 (Barges 2 and 3 only).
- h. Set seawater pressure regulator to supply 10 psi of seawater to chlorination unit.
- i. Start cooling pump by pressing START button on cooling pump motor controller on center bulkhead in void 2 port.
- j. While operating, perform during operation checks.

NOTE

Ballasting may be necessary to establish 9 inch bow high trim in preparation for towing or to establish barge on an even keel when deployed for processing water.

3-3.5 Filling ballast tank (to correct a bow high condition)

NOTE

Filling ballast tank requires only one seawater pump. The other seawater pump may be used to supply seawater to one ROWPU unit. See Figures 1-3 and 1-4 for seawater valve locations.

3-3.5.1 Filling ballast tank from forward seachest

- a. Perform before operation checks in paragraph 4-3.
- b. Open seawater valves SW31 thru SW34 in void 2 starboard.
- c. Close seawater valves SW4 thru SW8, SW11, SW12, SW18, and SW20 in void 2 starboard.

- d. Open or close seawater valves as follows:

o = open x = closed - = not affected

	SW valve no.:									
<u>Seawater supplied by:</u>	1	2	9	10	16	17	19	21	29	
Seawater pump 1 only	o	-	o	-	o	-	x	-	o	
Seawater pump 2 only	-	o	-	o	x	o	o	x	o	
Both seawater pumps	o	o	o	o	o	o	o	x	o	

- e. Make sure switchboard circuit breakers P6 and P7 are closed (ON).
 f. Start seawater pump using local control switch in void 2 starboard.

CAUTION

Do not overfill ballast tank.

- g. While filling ballast tank, perform during operation checks.
 h. To prevent overfilling, check ballast tank visual level indicator and display page on equipment monitoring system (EMS) video monitor. If EMS alarms sound, stop filling and stop alarms according to procedures in TM 55-1930-209-14 & P-11.
 i. Stop seawater pump when inclinometer in void 2 starboard indicates desired trim.

3-3.5.2 Filling ballast tank from starboard shell

- a. Perform before operation checks in paragraph 4-3.
 b. Open seawater valves SW31 thru SW34.
 c. Close seawater valves SW7, SW8, SW11, SW12, SW18, and SW20.
 d. Open or close seawater valves as follows:

o = open x = closed - = not affected

	SW valve no.:											
<u>Seawater supplied by:</u>	1	2	4	5	6	9	10	16	17	19	21	29
Seawater pump 1 only	x	-	o	o	x	o	-	o	-	x	-	o
Seawater pump 2 only	-	x	o	x	o	-	o	x	o	o	x	o
Both seawater pumps	x	x	o	o	o	o	o	o	o	o	x	o

- e. Perform steps e thru i in paragraph 3-3.5.1.

3-3.6 Draining ballast tank (to correct a stern high condition)

NOTE

Draining ballast tank requires only one seawater pump. The other seawater pump may be used to supply seawater to one ROWPU unit. See Figures 1-3 and 1-4 for seawater valve locations.

- a. Perform before operation checks in paragraph 4-3.
- b. Open seawater valves SW31 thru SW34 in void 2 starboard.
- c. Close seawater valves SW4, SW5, SW6, SW11, SW12, SW20, SW21, SW24, SW25, and SW29 in void 2 starboard.
- d. Open or close seawater valves as follows:

o = open x = closed - = not affected

<u>Ballast drained by:</u>	SW valve no.:									
	1	2	7	8	9	10	16	17	18	19
Seawater pump 1 only	x	-	o	x	o	-	o	x	o	o
Seawater pump 2 only	-	x	x	o	-	o	-	o	o	x
Both seawater pumps	x	x	o	o	o	o	o	o	o	o

- e. Make sure switchboard circuit breakers P6 and P7 are closed (ON).
- f. Start seawater pump using local control switch in void 2 starboard.
- g. While draining ballast tank, perform during operation checks.
- h. Stop seawater pump when inclinometer in void 2 starboard indicates desired trim.

3-3.7 Supplying seawater for generator cooling

WARNING

Do not open seawater valve SW37 unless valve SW44 is open.

NOTE

See Figures 1-6, and 1-7, and 1-8 for seawater valve locations.

- a. Make sure seawater valve SW44 in ROWPU space port aft corner is open to vent seachest to the atmosphere.
- b. Open valve SW37 in void 4 port.
- c. Open valves SW45 and SW46 to activate strainer pressure gauges (Barges 2 and 3 only).
- d. Open valve SW49 near void 4 starboard shell overboard discharge.
- e. Open seawater valves for generators to be used as follows:
 - (1) Ship service generator 1: SW38, SW39
 - (2) Ship service generator 2: SW40, SW41
 - (3) Ship auxiliary generator (20 kW): SW42, SW43

NOTE

Coolant pumps on generator engines move seawater from seachest through the engine coolant exchange tanks. The used seawater is discharged directly overboard through seawater valve SW49.

- f. While operating, perform during operation checks.

3-3.8 Seachest blowdown. Seachest blowdown is needed when gauges on input side of seawater strainers indicate a significant drop in water pressure. Blockage should be eliminated by using the following procedures. If compressed air is not available, start and operate the compressed air system in accordance with TM 55-1930-209-14 & P-7.

3-3.8.1 Forward seachest blowdown (serving ROWPU, chlorination, air conditioning, and ballast seawater systems)

CAUTION

Before starting forward seachest blowdown, make sure seawater cooling water pumps are not in use.

- a. Isolate seachest by closing valves SW1 and SW2. Make sure cooling pump is off. Close valve SW3.
- b. Check that compressed air pressure regulator 1 is set to 40 psi as shown on regulator gauge.
- c. Blowdown seachest on Barge 1 as follows:
 - (1) Position valve SW30 to position B so compressed air flows into seawater seachest.
 - (2) When air pressure regulator gauge reading stabilizes at 3-5 psi, position valve SW30 to position A to allow seachest to vent.
 - (3) Proceed to step e.
- d. Blowdown seachest on Barges 2 and 3 as follows:
 - (1) Close valve SW30.
 - (2) Open compressed air seawater seachest blowdown valve.
 - (3) When air pressure regulator gauge reading stabilizes at 3-5 psi, close compressed air seawater seachest valve and open valve SW30 to vent seachest.

WARNING

Do not open seachest valves SW1, SW2, or SW3 unless valve SW30 is positioned to allow seachest to vent.

- e. To return seachest to normal operation, open valves SW1, SW2, and SW3, and turn on cooling pump and seawater pumps as needed.
- f. If sea strainer inlet gauges do not indicate near normal reading, repeat steps a through e.

3-3.8.2 Aft seachest blowdown (serving generator cooling seawater system)

CAUTION

Before starting aft seachest blowdown, make sure generator sets are not operating.

- a. Isolate generator cooling seawater seachest by closing seawater valve SW37. Make sure all generators are shut down and not pulling seawater from seachest.
- b. Check that compressed air pressure regulator 2 is set to 40 psi as shown on regulator gauge.
- c. Close seawater valve SW44.
- d. Open generator cooling seachest blowdown valve in aft port corner of ROWPU space.

- e. When air pressure regulator gauge reading stabilizes at 3-5 psi, open valve SW44 to vent seachest.
- f. Close generator cooling seachest blowdown valve.

WARNING

Do not open seachest valve SW37 unless valve SW44 is open.

- g. To return seachest to normal operation, open valves SW37 and SW49. Start at least one of the generators and check sea strainer inlet gauges.
- h. If sea strainer inlet gauges do not indicate near normal reading, repeat steps a thru g above.

3-4 Seawater system shutdown procedures

CAUTION

This shutdown procedure shuts off seawater to the chlorination and air conditioning units. If these units are obtaining seawater from the seawater pumps, an alternative supply of seawater must be provided by following procedures in paragraph 3-3.4.

- a. Shutdown seawater system as follows:
 - (1) If ballasting, proceed according to paragraphs 3-3.5 and 3-3.6.
 - (2) If supplying seawater to ROWPU's using seawater pump(s) 1 and/or 2, proceed according to paragraph 3-4.1.
 - (3) If supplying seawater to generator cooling, proceed according to paragraph 3-4.2.
 - (4) If supplying seawater to air conditioning and chlorination units using cooling pump, proceed according to paragraph 3-4.3.
- b. Perform after operation checks.

3-4.1 Shutdown seawater supply to ROWPU's

- a. Stop seawater pump(s) by turning OFF/ON/START switch to OFF on ROWPU 1 and/or ROWPU 2 control station(s).
- b. Close valves SW1 and SW2 in void 2 starboard.

3-4.2 Shutdown generator cooling seawater supply

- a. Make sure all generator engines are stopped.
- b. Close valve SW37.

3-4.3 Shutdown seawater supply to air conditioning and/or chlorination units when using cooling pump.

- a. Push STOP button on cooling pump motor controller.
- b. Push main switch to OFF.
- c. Close valve SW3.

3-5 Emergency shutdown

3-5.1 General. The barge has two emergency shutdown modes. One mode shuts down individual systems such as the ventilation system or a diesel high pressure pump, and the other shuts down all barge operating systems.

- a. Both modes are activated by pushing a red button protected by a metal guard. On individual system shutdowns, either fuel or electrical power is shut off to that system only. On total shutdown, all fuel and electrical power is shut off to all operating systems.
- b. Seven red system shutdown buttons are located on the ROWPU space starboard bulkhead just aft of the personnel door. These system shutdown buttons (Figure 3-4) control shore power, ventilation systems, ROWPU 1 diesel high pressure pump, ROWPU 2 diesel high pressure pump, ship auxiliary generator, ship service generator 2, and ship service generator 1.
- c. Six red total shutdown buttons are located as follows:
 - (1) On ROWPU space starboard bulkhead aft of personnel door, above and forward of row of system shutdown buttons.
 - (2) Outside ROWPU space starboard door on weatherdeck.
 - (3) Outside ROWPU space port door on weatherdeck.
 - (4) Inside ROWPU space port door to weatherdeck.
 - (5) Outside dayroom door to weatherdeck.
 - (6) Inside dayroom door to weatherdeck.

3-5.2 Emergency shutdown procedures

- a. In an emergency, push appropriate red button to shut down either a selected system or all operating systems.
- b. When emergency situation has been corrected, reset emergency button by turning collar behind button one-quarter turn clockwise. Button will pop out and again be in ready position.
- c. When emergency button is reset, restart seawater system according to procedures in Chapter 3.

Section IV. Operation under extreme conditions

3-6 Operation under extreme conditions. Operation of seawater system in extreme cold creates a special problem with lubricants. Other problems occur during operation in extreme heat. These extreme conditions are discussed below. Additional information is contained in manufacturers' service manuals/instructions listed in Appendix B.

3-6.1 Operation in extreme cold. Cold weather lubricants must be used. Drain system if there is any danger of freezing.

3-6.2 Operation in extreme heat. Hot weather lubricants must be used. Electric motors have a tendency to run hot in high temperature areas. Electric motors contain internal circuits that automatically stop the motor before it gets hot enough to burn circuitry and bearings. When extreme internal heat triggers this automatic cutoff, allow the motor to cool before attempting to restart it.

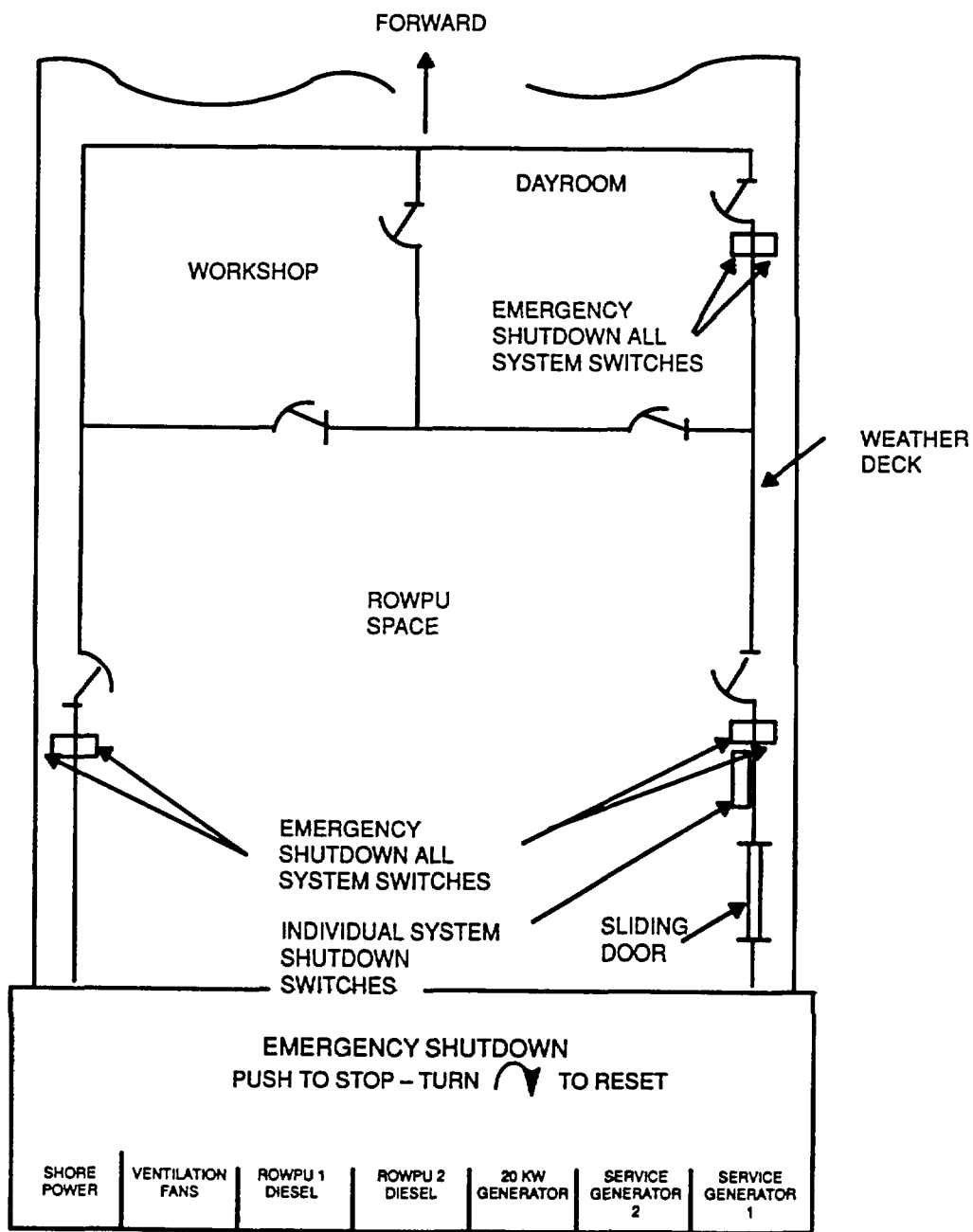

Figure 3-4. Location of Control Buttons for Emergency Shutdown Systems

CHAPTER 4 MAINTENANCE INSTRUCTIONS

Section I. General

4-1 Maintenance concept

4-1.1 Unit level and Intermediate Direct Support and Intermediate General Support (IDS/IGS) maintenance on seawater system is performed onboard by barge crewmembers whenever possible.

4-1.2 Any IDS/IGS maintenance beyond capability of crewmembers is provided by a shore-based area support maintenance unit. This unit also determines depot support requirements.

4-1.3 Intermediate support maintenance is accomplished by replacement of components or major end items.

4-1.4 Unless other intermediate support procedures are directed, IDS/IGS maintenance normally is provided by an Army Transportation Corps floating craft intermediate support maintenance unit serving terminal operating area. Components to be disposed of are processed by this unit.

4-1.5 Maintenance Allocation Chart (MAC) is in Appendix C of TM 55-1930-209-14 & P-18. Consult appropriate manual for maintenance of other equipment onboard.

4-2 Maintenance Instructions. Maintenance instructions are presented as follows: Section II, Preventive maintenance; Section III, Troubleshooting; and Section IV, Maintenance procedures.

Section II. Preventive maintenance checks and services

4-3 See TM 55-1930-209-14&P-2, Appendix C for preventive maintenance checks and services for the Seawater System. See TM 55-1930-209-14&P-19 for complete preventive maintenance checks and services for all ROWPU Barge Systems.

Section III. Troubleshooting

4-4 Component

- a. Troubleshoot seawater pumps according to Table 4-1.
- b. Troubleshoot cooling pump according to Table 4-2.

4-5 Seawater system. Troubleshoot seawater system according to Table 4-3.

Section IV. Maintenance procedures

4-6 General. Maintenance for this system consists of lubricating, disassembling, repairing and/or replacing, and reassembling items involving repair parts listed in Appendix G of TM 55-1930-209-14 & P-18. No special tools are required. When performing maintenance, be sure to observe these approved shop practices.

WARNING

Be sure electrical power is off before performing maintenance or repair on this system. OPEN circuit breakers. Redtag circuit breakers or motor controller with "WARNING - DO NOT ACTIVATE. REPAIRS BEING MADE." Observe safety precautions in this TM and in manufacturers' manuals/instructions.

- a. Always use new seals and gaskets before reassembling components disassembled for repair. Be sure to use only new seals and gaskets same as the original. Carefully install so as not to damage seals and gaskets during assembly.
- b. When replacing O-rings, make sure all surfaces are clean and free of dirt, grit, or foreign material. Prior to installation, apply a thin coat of silicone grease to O-ring for ease of assembly. Protect O-rings by applying tape over threads, sharp corners, and edges.
- c. To ensure a leak-proof joint when replacing gaskets, make sure mating surfaces are clean and free of old gasket material, adhesive, oil, or grease.
- d. When replacing electrical components, follow, proper procedures for soldering or crimping connections. Check all grounding. Make sure current carrying members are properly insulated to avoid short-circuits. Check insulation on wires and cables for abrasions and chafing. Repair or replace as necessary.

Table 4-1. Seawater Discharge Pump and Cooling Pump Troubleshooting

<u>Problem</u>	<u>Probable Cause</u>	<u>Suggested Action</u>
1. Pump leaks around shaft	a. Worn seal	a. Replace seal (paragraph 4-7.2.1.2 for seawater discharge pump or paragraph 4-7.2.8.2 for cooling pump)
2. Pump does not deliver rated capacity	a. Impeller is worn or damaged	a. Replace impeller (paragraph 4-7.2.2 for seawater discharge pump or paragraph 4-7.2.8.2 for cooling pump)
	b. Leaks in suction line	b. Inspect piping, repair leaks (paragraph 4-7.2.6)
	c. Seachest blocked	c. Blowdown forward seachest in Void 2 Starboard (paragraph 3-3.8.1)
	d. Strainer basket clogged	d. Change flow and clean basket (paragraph 4-7.2.3.2)
	e. Suction valve SW1 or SW2 partially or fully closed	e. Open valve
3. Motor will not stop or stops after running short time	a. Seawater discharge pump OFF/ ON/START and local START/ STOP switches or cooling	a. Test and repair (paragraph 4-7.2.6.2 for seawater discharge pump or Table 4-2 and paragraph 4-7.2.7.2 for cooling pump)
	b. Low input voltage pump motor controller malfunctions	b. Check voltage
4. Motor runs too slow under load	a. Line voltage is too low	a. Check line voltage (paragraph 4-7.2.6.2 for seawater discharge pump or paragraph 4-7.2.7.2 for cooling pump)

Table 4-1. Seawater Discharge Pump and Cooling Pump Troubleshooting (Cont'd)

<u>Problem</u>	<u>Probable Cause</u>	<u>Suggested Action</u>
5. Motor runs too fast under load	a. Line voltage is too high	a. Check line voltage (paragraph 4-7.2.6.2 for seawater discharge pump or paragraph 4-7.2.7.2 for cooling pump)
6. Motor fails to start but gives a loud hum	a. One of the phases to motor is not energized	a. Check thermal overload units in motor controller and replace if necessary. Check cable continuity to motor (paragraph 4-7.2.6.2 for seawater discharge pump or paragraph 4-7.2.7.2 for cooling pump)

Table 4-2. Cooling Pump Motor Controller Troubleshooting

<u>Problem</u>	<u>Probable Cause</u>	<u>Suggested Action</u>
1. Motor controller fails to operate	a. Motor controller is malfunctioning	a. Visually check for signs of heat, smoke, or smell of burning insulation. Replace damaged part or repair as given in step 4
	b. Bad fuse	b. Replace fuse
2. Motor controller fails to start motor after pressing START button and overload relay reset button	a. If system remains dead, motor controller at fault	a. Check motor controller (paragraph 4-7.2.7.2) relay reset button
	b. If power contacts close power circuit at fault	b. Check power circuit to motor (paragraph 4-7.2.7.2)
	c. If motor fails to start and give	
3. Contacts chatter	a. Poor contact in control relay	a. Clean relay contact
4. Overheated contacts	a. Dirty contact tips	a. Clean relay contacts
	b. Loose connections	b. Clean and tighten
5. Noisy magnet	a. Broken coil	a. Replace
	b. Dirt or rust on magnet	b. Clean
	c. Low voltage	c. Check system voltage and correct if wrong
6. Magnet failure to drop out	a. Gummy substance on magnet faces	a. Clean with approved solvent

Table 4-2. Cooling Pump Motor Controller Troubleshooting (Cont'd)

<u>Problem</u>		<u>Probable Cause</u>	<u>Suggested Action</u>
7	Thermal overload unit	a. Wrong size heater	a. Install correct size
8.	Thermal overload unit trips at too low temperature	a. Wrong size heater	a. Install correct size

Table 4-3. Seawater System Troubleshooting

<u>Problem</u>		<u>Probable Cause</u>	<u>Suggested Action</u>
1.	Seawater pump 1 not operating	a. Local START/STOP switch STOP button depressed (Figure 3-1) b. Station on OFF/ON/START in off position (Figure 4-1) c. Circuit breaker P6 on main distribution panel open (OFF) d. Station OFF/ON/START local START/STOP switches malfunctioning e. Seawater pump malfunctioning	a. Depress START button b. Start pump c. Close (ON) circuit breaker d. Troubleshoot (paragraph 4-7.2.6.2) e. Troubleshoot (Table 4-1)
2.	Seawater pump 2 not operating	a. Local START/STOP switch STOP button depressed (Figure 4-1) b. Station OFF/ON/ START start in OFF position (Figure 4-1) c. Circuit breaker P7 on main distribution panel open (OFF) d. Station OFF/ON/START and/or local START/STOP switches malfunctioning e. Seawater pump malfunctioning	a. Depress START button b. Start pump c. Close (ON) circuit d. Troubleshoot (paragraph 4-7.2.6.2) e. Troubleshoot (Table 4-1)

Table 4-3. Seawater System Troubleshooting (Cont'd)

<u>Problem</u>	<u>Probable Cause</u>	<u>Suggested Action</u>
3. Cooling pump not operating	a. Motor controller off (Figure 4-1)	a. Start pump by closing switch and pushing START button
	b. Circuit breaker 1P5 on power panel 1 open (OFF)	b. Close (ON) circuit breaker
	c. Cooling pump malfunctioning	c. Troubleshoot (Table 4-1)
4. Seawater intake pressure inadequate	a. Seachest blocked	a. Blowdown forward seachest in Void 2 Starboard (paragraph 4-3.8.1)
	b. Strainer basket clogged	b. Change flow and clean basket (paragraph 4-7.2.3.2)
	c. Suction valve SW1 or SW2 partially or fully closed	c. Open Valve
5. Seawater not being supplied to ROWPU	a. Valve SW1, SW2, or SW4 closed	a. Open valve SW1 or SW2 if water is to be supplied from seachest or valve SW4 if water is to be supplied from starboard shell penetration
	b. Seawater strainer valve(s) SW9 and/or SW10 closed	b. Open valve(s)
	c. Seawater pump(s) 1 and/or 2 malfunctioning	c. Troubleshoot seawater pump(s) (Table 4-1)
	d. Seawater strainer clogged	d. Switch to alternate strainer and clean clogged strainer (paragraph 4-7.2.3)
	e. Seawater pump discharge valve(s) SW16, SW17, and/or SW19 closed	e. Open valve(s) SW16, and/or SW19 closed
	f. Seawater filter supply valves SW20 and SW21 closed	f. Open valves SW20 and SW21
	g. Seawater filters clogged	g. Open dump valve on filters and drain (paragraph 4-7.2.5)
	h. Piping clogged	h. Unclog piping
6. Seawater not being supplied to chlorination system from seawater pumps	a. Valves SW24, SW25, and SW48 closed	a. Open valves SW24, SW25, and SW48 system from seawater pumps
	b. Valve SW47 open	b. Close valve SW47

Table 4-3. Seawater System Troubleshooting (Cont'd)

<u>Problem</u>	<u>Probable Cause</u>	<u>Suggested Action</u>
	c. Seawater pressure regulator closed	c. Open pressure regulator to 10 psi
	d. Seawater pump 1 or 2 malfunctioning	d. Troubleshoot (Table 4-1)
	e. In-line filter clogged	e. Replace filter (paragraph 4-7.2.11)
7. Seawater not being supplied to chlorination system through the cooling pump	a. Valve SW47 closed	a. Open valve SW47
	b. Seawater strainer clogged	b. Switch to alternate strainer and clean clogged strainer (paragraph 4-7.2.3)
	c. Seawater pressure regulator closed	c. Open pressure regulator to 10 psi
	d. Air conditioning cooling pump malfunctioning	d. Troubleshoot (Table 4-1)
	e. Valve(s) SW3 and/or SW27 closed	e. Open valve(s) SW3 and/or SW27
	f. In-line filter clogged	f. Replace filter (paragraph 4-7.2.11)
	g. Piping clogged	g. Unclog piping
8. Seawater not being supplied to air conditioning unit from cooling pump	a. Valve SW28 closed	a. Open valve SW28
	b. Cooling pump malfunctioning	b. Troubleshoot (Table 4-1)
	c. Seawater strainer clogged	c. Switch to alternate strainer and clean clogged strainer (paragraph 4-1.3)
	d. Valve(s) SW3 and/or SW27 closed	d. Open valve(s) SW3 and/or SW27
	e. Piping clogged	e. Unclog piping
9. Seawater not being supplied to ballast tank	a. Seawater not getting to ballast tank supply valve SW29	a. Troubleshoot seawater supply lines as given in problem 5, a thru e
	b. Piping clogged	b. Unclog piping

Table 4-3. Seawater System Troubleshooting (Cont'd)

<u>Problem</u>	<u>Probable Cause</u>	<u>Suggested Action</u>
10. Seawater not draining from ballast tank	a. Ballast tank drain valve(s) SW7 and/or SW8 closed	a. Open valve(s) SW7 and/or SW8 closed
	b. Overboard discharge valve SW18 closed	b. Open valve SW18
	c. Seawater not flowing to discharge valve	c. Troubleshoot seawater supply lines as given in problem 5, b thru e
	d. Piping clogged	d. Unclog piping
11. Generator cooling seawater intake pressure not high enough	a. Seachest blocked	a. Blowdown aft seachest (paragraph 3-3.8.2)
12. Seawater not flowing through generator to discharge valve SW49	a. Seachest valve SW37 not open	a. Open valve SW37
	b. Seawater strainer clogged	b. Switch to alternate strainer and clean clogged strainer (paragraph 4-7.2.3)
	c. Generator supply valve(s) SW38, SW40, SW41, and/or SW42	c. Open valve(s) SW38, SW40, and/or SW42
	d. Generator discharge valve(s) SW39, SW41 and/or SW43 closed	d. Open valves SW39, SW41, and/or SW43
	e. Overboard discharge valve SW49 closed	e. Open valve SW49
	f. Piping clogged	f. Unclog piping

NOTE

Due to this vessel's mission and crew capabilities, maintenance normally assigned to unit level or higher echelons of maintenance may be assigned to the crew.

4-7 Seawater system. This section describes lubrication and repair of the seawater system involving repair parts listed in Appendix G of TM 55-1930-209-14 & P-18.

WARNING

Shut down seawater system before attempting any repair. Be sure to open circuit breakers. Redtag circuit breakers with: "WARNING - DO NOT ACTIVATE. REPAIRS BEING MADE."

4-7.1 Lubrication. Lubricate seawater pump motor with three drops of oil in each oil hole. Lubricate cooling pump motor with light machine oil in each hole.

4-7.2 Repair or replacement of system components

4-7.2.1 Seawater discharge pump assembly

4-7.2.1.1 Cleaning and Inspection

- a. Pump.
 - (1) Clean exterior of pump with brush and hot soapy water or with an approved solvent. Rinse thoroughly dry with filtered compressed air.
 - (2) Visually check pump for evidence of cracks, corrosion, or damage. Remove corrosion.
- b. Motor.
 - (1) Clean motor exterior using filtered compressed air or vacuum. Wipe off using rag moistened with an approved solvent. Clean terminals and wipe wires free with lint-free cloth or electrician's brush.
 - (2) Visually inspect for burned, bent, loose, corroded, or otherwise damaged terminals. Inspect wiring for breaks, loose connections, or other obvious damage. Tighten loose connections, replace damaged terminals, and replace damaged wiring. Touch up paint according to TB 43-0144.

4-7.2.1.2 Repair

- a. Removal. Remove seawater pumps assembly from mounting according to the following procedures:

WARNING

Make sure pump motor controller(s) are electrically dead before starting removal.

- (1) Open (OFF) switchboard circuit breakers P6 (ROWPU BOOSTER PUMP No. 1) and (ROWPU BOOSTER PUMP No. 2). Redtag circuit breakers with: "WARNING - DO NOT ACTIVATE. REPAIRS BEING MADE."
- (2) If seawater pump 1 is to be removed, close valves SW9, SW 11, SW1 6, and SW24. If seawater pump 2 is to be removed, close valves SW10, SW12, SW17, and SW25.
- (3) Tag and disconnect electrical wiring.
- (4) Disconnect all piping to pump assembly and allow water to drain into bilge.
- (5) Remove mounting bolts and remove pump assembly.
- b. Disassembly and repair of seawater pump. Disassemble and repair seawater pump TC-30 according to the manufacturer's service manual in Appendix B. Use repair parts listed in Appendix G of TM 55-1930-209-14 & P-18. Retouch or paint in accordance with TB 43-0144.
- c. Repair of motor. Repair motor by tightening loose connections, replacing damaged terminals, or replacing damaged wiring.
- d. Reinstallation of seawater pumps assembly.
 - (1) Reinstall pump assembly and tighten mounting bolts.
 - (2) Connect all piping.

- (3) Connect electrical wiring as tagged.
- (4) Energize pump motor controllers by closing switchboard circuit breakers P6 and P7 to provide power to seawater pump motor controllers. Remove red tags.
- (5) Open valves SW9, SW11, SW16, and SW24 if pump 1 was removed. Open valves SW10, SW12, SW17, and SW25 if pump 2 was removed.

CAUTION

Seawater pumps are self-priming and are cooled by water passing through the pump. If pumps are operated without water, they will be damaged.

- (6) Momentarily energize pump motor controller by turning power on and starting pump 1 or 2 (Figure 3-1). Listen for pump moving water. If pump is moving water, repair is complete. Make appropriate entry in maintenance records. If pump does not start moving water within 30 seconds, turn off pump and troubleshoot.

4-7.2.1.3 Replacement

- a. Removal. Remove seawater discharge pump assembly as indicated in step a in paragraph 4-7.2.1.2.
- b. Installation. Obtain seawater pump assembly from void 4 starboard. Install seawater discharge pump assembly as indicated in step d in paragraph 4-7.2.1.2.

4-7.2.2 Seachest (Void 2 starboard or Void 4 port)

4-7.2.2.1 Cleaning and inspection

- a. Clean exterior of seachest with brush and hot soapy water or an approved solvent. Wipe dry with a clean cloth.
- b. Visually check for corrosion, chipped paint, or leaks. Remove corrosion and touch up paint according to TB 43-0144. Replace flange gaskets to stop leaks. Replace access cover gaskets as given in paragraph 4-7.2.2.2.

4-7.2.2.2 Repair. Replace access plate gasket as follows:

- a. Remove 19 nuts with lockwashers attaching access plate with synthetic rubber gasket.
- b. Remove access plate with gasket.
- c. Remove gasket from access plate.
- d. Clean tank and access plate mating surface.
- e. Install access plate with new gasket.
- f. Secure access plate with 19 nuts and lock washers.
- g. Touch up paint in accordance with TB 43-0144.
- h. Check for leaks.

4-7.2.3 Seawater strainer

4-7.2.3.1 Cleaning and inspection

- a. Clean exterior of strainers listed below with brush and hot soapy water or an approved solvent. Wipe dry with clean cloth. Clean or switch strainer basket as given in paragraph 4-7.2.3.2 below.

<u>STRAINER LOCATION</u>	<u>QUANTITY</u>
Void 2 starboard	2
Void 2 port	1
Void 4 port	1

- b. Visually check for leaks. Replace flange gasket or cover gasket to stop leaks.

4-7.2.3.2 Seawater strainer basket switching and cleaning. When pressure difference (see list below) indicates seawater strainer must be cleaned, basket must be switched (T-bolt handle or handwheel type) and dirty basket must be cleaned as follows.

<u>STRAINER LOCATION</u>	<u>PRESSURE GAUGE DIFFERENCE</u>	<u>BARGE</u>
Void 2 starboard	8	1, 2, and 3
Void 2 port	8	1, 2, and 3
Void 4 port	2	2 and 3

- a. Changing flow.
 - (1) Loosen diverter plug locking flange by turning locking T-bolt handle/handwheel counterclockwise.
 - (2) Turn handle toward clean basket until it stops.

NOTE

Never operate strainer with diverter plug unseated. Sediment may collect under plug and prevent a tight seal.

- (3) Tighten locking flange by turning locking T-bolt handle/handwheel clockwise to seat diverter plug. Do not over tighten.
- b. Removing and cleaning strainer basket.
 - (1) Loosen yoke screw until yoke swings free.
 - (2) Pull basket handle straight up to remove basket.

CAUTION

Do NOT leave basket well open for more than 10 minutes. Diverter plug does not completely cut off water and water will seep into open well.

Do NOT use any petroleum based products to clean basket. Be careful not to damage basket. Do not use wire brush.

- (1) Clean basket on weatherdeck with soft brush and flush with drinking water.
- (2) Use compressed air to dislodge difficult particles.
- (3) Flush with drinking water.
- (4) Wipe interior of basket with clean cloth before reinstalling.

- c. Replacing strainer basket.
 - (1) Lower cleaned basket, or new basket if existing basket cannot be cleaned, into well.
 - (2) Swing yoke over basket well until end fits over stud.
 - (3) Be sure O-rings on cover rest in machined grooves before tightening yoke screw securely. Do NOT overtighten.

4-7.2.3.3 Replacement

- a. Removal.
 - (1) Close following Seawater System (SW) valves:

<u>STRAINER LOCATION</u>	<u>VALVES</u>
Void 2 starboard	SW1, SW9 (Strainer 1)
	SW2, SW10 (Strainer 2)
Void 2 port	SW3, SW27 (Strainer 3)
Void 4 port	SW37, SW38

- (2) Disconnect piping
 - (3) Remove mounting hardware.
 - (4) Remove strainer.
- b. Installation. Install strainer in reverse order of removal in step a.

4-7.2.4 Strainer Inlet and outlet pressure gauges

4-7.2.4.1 Cleaning and Inspection

- a. Wipe clean pressure gauges listed below with rag dampened with hot soapy water or an approved solvent. Wipe dry with clean cloth.

<u>PRESSURE GAUGE LOCATION</u>	<u>BARGE</u>
Void 2 starboard	1, 2, and 3
Void 2 port	1, 2, and 3
Void 4 port	2 and 3

- b. Visually inspect for damage or leaks. Correct leak by tightening or replacing connector or tubing. Replace damaged pressure gauge.

4-7.2.4.2 Replacement

- a. Removal.
 - (1) Close following seawater valves as necessary:

<u>VALVE</u>	<u>VALVE LOCATION</u>	<u>BARGE</u>
SW31 or SW32	Void 2 starboard	1, 2, and 3
SW33 or SW34	Void 2 starboard	1, 2, and 3
SW34 or SW35	Void 2 port	1, 2, and 3
SW45 or SW46	Void 4 port	2 and 3

- (2) Remove pressure gauge.
- (3) Cover tube opening to prevent foreign material from entering.
- b. Installation. Install pressure gauge in reverse order of removal in step a.

4-7.2.5 Seawater filter 1 and 2 (Lakos separator)

4-7.2.5.1 Cleaning and Inspection

- a. Wipe clean exterior of filter with rag dampened with hot soapy water or an approved solvent. Wipe dry with clean cloth.
- b. Visually inspect exterior for damage, leaks, corrosion, or chipped paint. Clean corrosion and touch up paint according to TB 43-0144. Open inspection/clean port located on top at lower end of filter and inspect for larger particles. Remove larger particles if necessary.

4-7.2.5.2 Seawater filter purging and draining. Seawater filters 1 and 2 (separators) must be regularly purged during seawater system operation to prevent solids from overflowing filter collection chambers.

- a. Purge according to the following schedule:
 - (1) In water that is not overly dirty or contaminated - about 15 seconds during every 8 hours of operation.
 - (2) In water that is dirty - about 15 seconds during every hour of operation or as needed.
- b. Drain filters by:

NOTE

Drain only filter(s) in active use. If only one ROWPU system is in use with just one seawater pump, then drain only filter(s) in use.

- (1) Opening seawater valves SW22 (filter 1), SW23 (filter 2), and SW26 for time specified in paragraph a above.
- (2) Close valves SW22, SW23, and SW26.
- (3) Record time/date of purging in operations log.

4-7.2.5.3 Replacement

- a. Removal.
 - (1) Close seawater valves SW20 and SW22 of seawater filter 1 or SW23 and SW26 of seawater filter 2.
 - (2) Disconnect piping from filter.
 - (3) Remove hardware securing filter to deck and remove filter.
- b. Installation. Install filter in reverse order of removal in step a. Refer to the installation procedures in the manufacturer's service manual in Appendix B.

4-7.2.6 Seawater discharge pump OFF/ON/START and local START/STOP switches.

WARNING

Make sure ROWPU control station 1 or 2 is electrically dead before starting repair or removal. Redtag switchboard circuit breaker P6 (ROWPU BOOSTER PUMP No. 1) or P7 (ROWPU BOOSTER PUMP No. 2). Redtag circuit breaker with: "WARNING - DO NOT ACTIVATE. REPAIRS BEING MADE."

4-7.2.6.1 Cleaning and inspection

- a. Make sure ROWPU control station for pump being repaired is electrically dead by opening (OFF) switchboard circuit breaker P6 for seawater pump 1 or P7 for seawater pump 2. Redtag circuit breaker with: "WARNING - DO NOT ACTIVATE. REPAIRS BEING MADE."
- b. Wipe clean exterior of control station with clean rag. Open control station door and vacuum clean or clean inside with electrician's brush. Avoid using solvents for cleaning inside of control station. Solvents leave a greasy film on components that may reduce electrical conductivity.
- c. Check fuse. Replace if necessary.
- d. Visually inspect for indications of burns, corrosion, loose connections, damaged parts, or chipped paint. Clean corrosion from contacts and terminals, tighten loose connections, and replace damaged parts. Clean electrical contacts with silver polish, fine sandpaper, or burnishing tool. DO NOT use emery paper or emery cloth or steel wool. Vacuum to remove residue. Touch up paint according to TB 43-0144.

4-7.2.6.2 Test and repair

- a. With main circuit breaker P6 or P7 on switchboard closed (ON). Check control station input line voltage across points L1 and L2, L2 and L3, and L1 and L3 (Figure 4-1). If voltage across any two points is 0, power source is at fault. Go to step b to correct problem. If voltage across all three pairs of points is 440, go to step c to check control station output voltage.
- b. Check circuit breaker P6 or P7 output line voltage. If voltage across any two lines is 0, circuit breaker or power source is at fault. If circuit breaker voltage across all three line pairs is 440, replace power cable from circuit breaker to control station.
- c. Check control station output line voltage across points T1 and T2, T2 and T3, and T1 and T3. If voltage reading across any of the terminal pairs is 0, check motor controller thermal units using Figure 4-1 as given in step d below. If voltage across all terminal pairs is 440, pump motor is at fault and check motor as given in paragraph 4-7.2.1.
- d. Check voltage of overload protection thermal units across points K1 and K2, K2 and K3, and K1 and K3. If voltage across any terminal pair is 0, replace faulty overload protection thermal unit. If voltage across all terminal pairs is 440, go to step e.
- e. Check transformer output voltage from terminal board TB 12 to TB 19. If voltage is 110, go to step f. If voltage reading is not 110, check continuity of fuse and wire from transformer to TB12 and wire from transformer to TB19. Replace fuse or wire if at fault.
- f. Check transformer input voltage across points L1 and L2. If voltage is not 440, replace wires to transformer. If voltage is 440 and voltage in step e was 0, replace transformer. If voltage is 440 and voltage in step e was 110, go to step g.
- g. Open (OFF) and secure main circuit breaker P6 or P7 on switchboard and check control station continuity as follows:
 - (1) Check continuity of ON/OFF/START switch in ON position from terminal board TB12 to TB6. If check indicates a closed circuit, go to step (2). If check indicates an open circuit, check continuity of wires from points P1 to TB6 and TB12 to P3. If check indicates an open circuit in wire, replace faulty wire. If check indicates a closed circuit in both wires, replace faulty ON/OFF/START switch.
 - (2) Depress pump 1 or pump 2 local STOP switch and check continuity from TB14 to TB15. If check indicates closed circuit, go to step (3). If check indicates an open circuit, check continuity of wires from TB14 to S4 and TB 15 and S3. If check indicates an open circuit, replace faulty wires. If check indicates a closed circuit in both wires, replace faulty STOP switch.

- (3) Depress pump 1 or pump 2 local START switch and check continuity from P2 to L4. If check indicates closed circuit, go to step (4). If check indicates an open circuit, replace faulty wire. If check indicates an open circuit, check continuity of wires from P2 to S2 and L4 to S1. If check indicates closed circuit in all wires, replace faulty START switch.
 - (4) Check continuity of wires from L4 to M1, M2 to N1, and N2 to TB14. If check indicates closed circuit, go to step h. If check indicates an open circuit, replace faulty wires.
- h. If no fault was found in steps e thru g, replace main contactor.

4-7.2.7 Cooling pump motor controller

WARNING

Make sure cooling pump motor controller is electrically dead before starting repair or removal. Redtag power panel 1 circuit breaker 1P5 with: "WARNING - DO NOT ACTIVATE. REPAIRS BEING MADE."

4-7.2.7.1 Cleaning and inspection

- a. Make sure cooling pump motor controller is electrically dead by opening (OFF) power panel 1 circuit breaker 1P5. Redtag circuit breaker with: "WARNING - DO NOT ACTIVATE. REPAIRS BEING MADE."
- b. Wipe clean exterior of motor controller with clean rag. Open motor controller door and vacuum clean or clean inside with electrician's brush. Avoid using solvents for cleaning inside of motor controller. Solvents leave a greasy film on components that may reduce electrical continuity.
- c. Check fuse. Replace if necessary.
- d. Visually inspect for indications of burns, corrosion, loose connections, damaged parts, or chipped paint. Clean corrosion from contacts and terminals, tighten loose connections, and replace damaged parts. Clean electrical contacts with silver polish, fine sandpaper, or burnishing tool. DO NOT use emery paper or steel wool. Vacuum to remove residue. Touch up paint according to TB 43-0144.

4-7.2.7.2 Test and repair

- a. With power panel 1 circuit breaker 1P5 closed (ON), check motor controller input line voltage across points A1 and B1, B1 and C1, and A1 and C1 (Figure 4-2). If voltage across any terminal pairs is 0 power source is at fault, go to step b to correct problem. If voltage across all three terminal pairs of points is 440, go to step c.
- b. Check circuit breaker 1P5 output line voltage. If voltage across any terminal pairs is 0, circuit breaker or power source is at fault. If circuit breaker voltage across all three terminal pairs is 440, replace power cable from circuit breaker to motor controller.
- c. Close motor controller disconnect switch and check line voltage across points A2 and B2, B2 and C2, and A2 and C2. If voltage across any terminal pair is 0, check main contactor contacts. If bad or corroded, clean or replace contacts. If contacts are good, replace disconnect switch. If voltage across all three terminals is 440, go to step d to check motor controller output voltage.
- d. Check output voltage across points T1 and T2, T2 and T3, and T1 and T3. If voltage across any terminal pairs is 0, go to step e. If voltage across all three terminal pairs is 440, check motor connections and continuity of wires from motor controller to motor. If connections and wires are good, replace motor.
- e. Check voltage of overload protection thermal units across points N1 and T1, N2 and T2, and N3 and T3. If voltage across any terminal pair is 0, replace faulty overload protection thermal unit. If voltage across all terminal pairs is 440, go to step f.

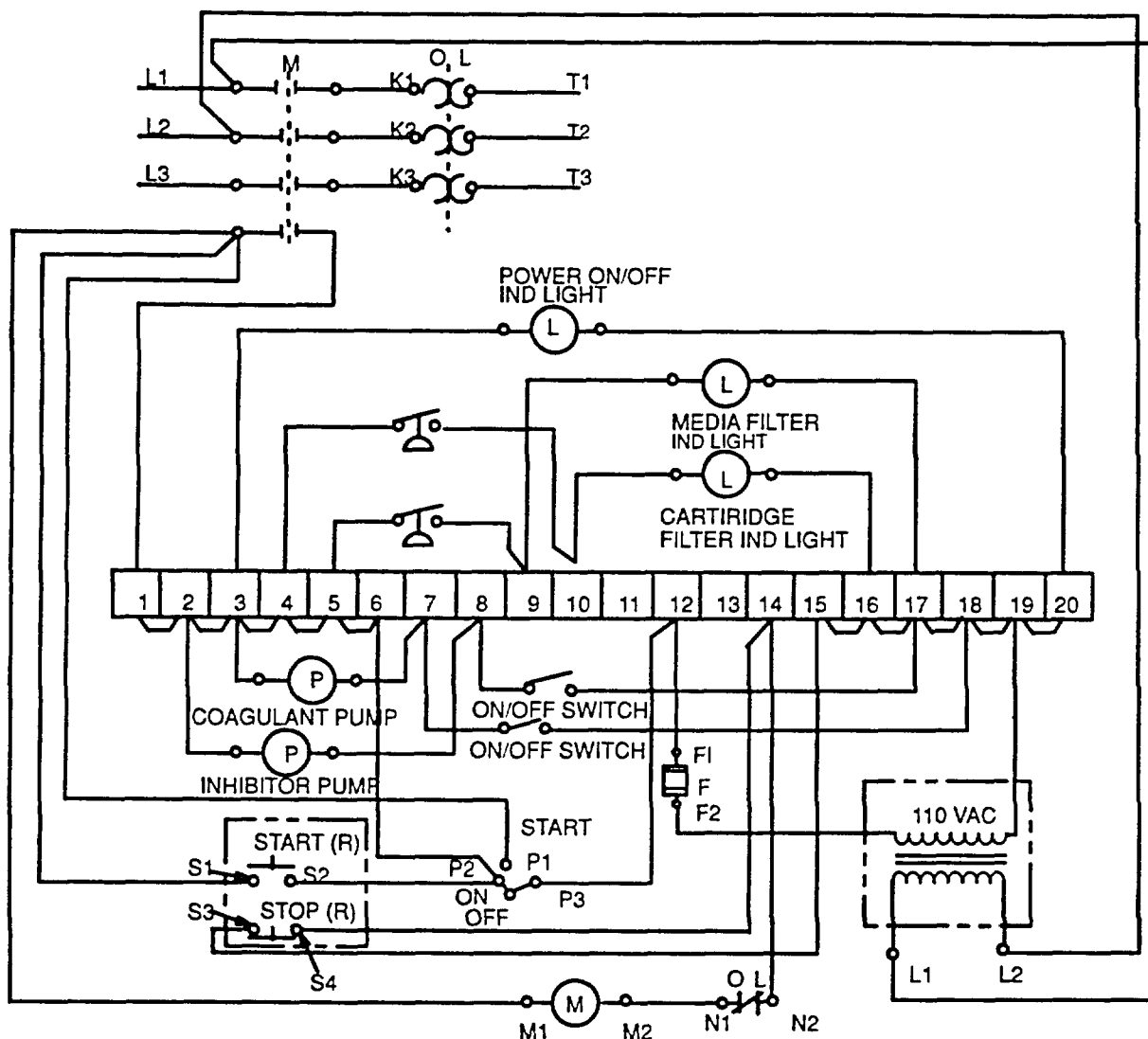

Figure 4-1. ROWPU Control Station Schematic

- f. Check transformer input voltage across points L1 and L2. If voltage is not 440, replace wires to transformers. If voltage is 440, check transformer output voltage across points X1 and X2. If voltage is not 110, replace transformer. If voltage is 110, go to step g.
- g. Open (OFF) and secure power panel 1 circuit breaker 1P5 and check motor controller continuity as follows:
 - (1) Check continuity of wires from X1 to TB1. If check indicates a closed circuit, go to step h. If check indicates an open circuit, check continuity of wire from points X1 to J1 and from points J1 to TB1. If check indicates an open circuit, replace faulty wire. If checks indicates all closed circuits, replace fuse.

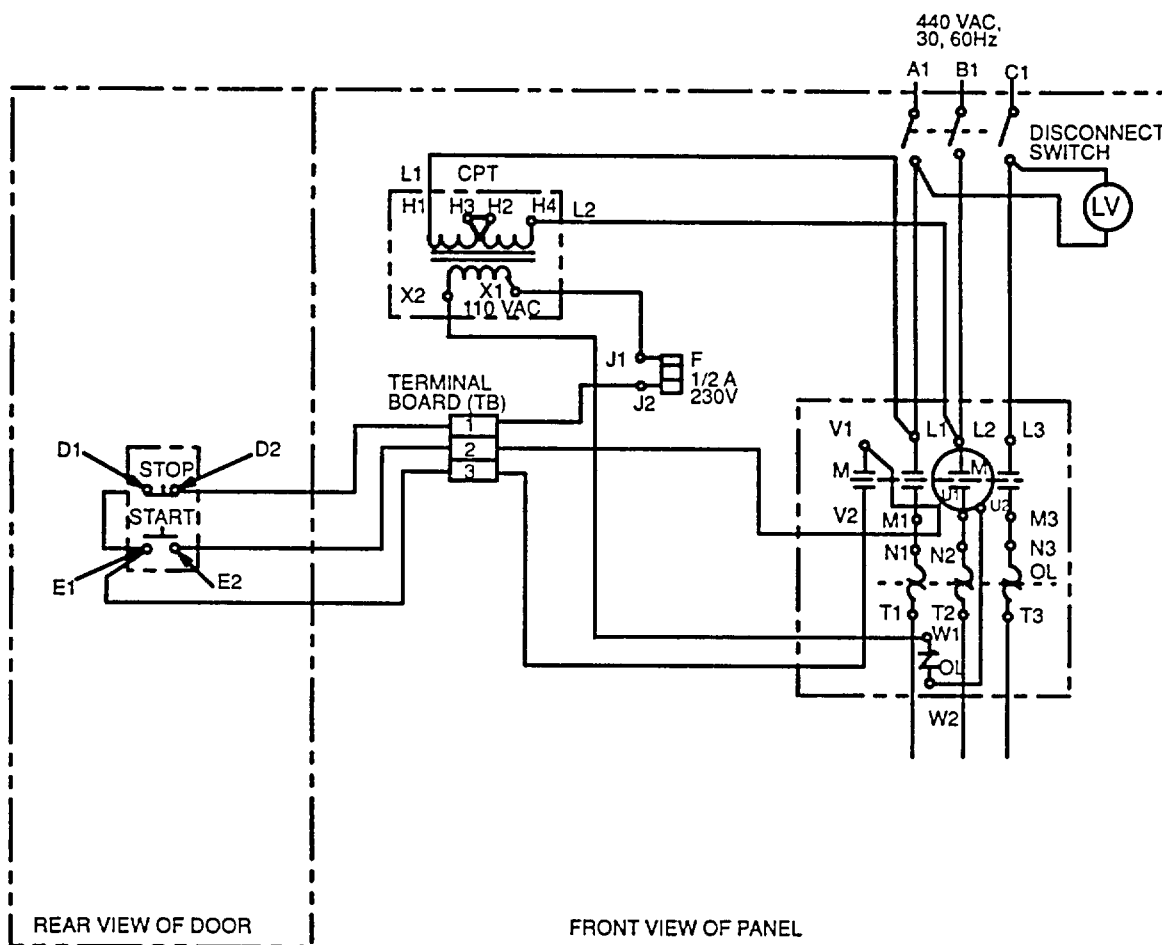

Figure 4-2. Cooling Pump Motor Controller Schematic

- (2) Depress STOP switch and check continuity of wires from TB1 to TB3. If check indicates a closed circuit, go to step (3). If check indicates an open circuit, check continuity of wires from TB1 to D2 and TB3 and D1. If check indicates an open circuit, replace faulty wires. If check indicates a closed circuit in all wires, replace faulty STOP switch.
 - (3) Depress START switch and check continuity of wires from TB2 to TB3. If check indicates a closed circuit, go to step (4). If check indicates an open circuit, check continuity of wires from TB2 to E2 and TB3 to E1. If check indicates an open circuit, replace faulty wires. If check indicates a closed circuit in all wires, replace faulty START switch.
 - (4) Check continuity of wires from main contactor coil connection U1 to TB2, auxiliary contact of main contactor connection V2 to TB3, overload contact connection W1 to transformer connection X2, and overload contact connection W2 to main contactor coil connection U2. If check indicates an open circuit, replace faulty wires. If check indicates a closed circuit in all wires, go to step h.
- h. If no fault was found in steps e thru g, replace main contactor.

4-7.2.7.3 Replacement

- a. Removal.

WARNING

Make sure cooling pump motor controller is electrically dead before starting repair by opening (OFF) circuit breaker 1P5 on power panel. Redtag circuit breaker with: "WARNING - DO NOT ACTIVATE. REPAIRS BEING MADE."

- (1) Tag and disconnect wiring with connection information.
 (2) Remove attaching hardware and remove motor controller.
- b. Installation
- (1) Install motor controller using attaching hardware
 (2) Connect wiring
 (3) Close (ON) circuit breaker 1P5 on power panel
 (4) Check operationally that motor controller operates normally.

4-7.2.8 Cooling pump

4-7.2.8.1 Cleaning and Inspection

- a. Pump.

- (1) Clean exterior of pump with brush and hot soapy water or with an approved solvent. Rinse thoroughly and dry with filtered compressed air.
 (2) Visually check pump for evidence of cracks, corrosion, or damage. Remove corrosion. Touch up paint according to TB 43-0144.

- b. Motor.

- (1) Clean motor exterior using filtered compressed air or vacuum. Wipe off using rag moistened with an approved solvent. Clean terminals and wipe wires free with lint-free cloth or electrician's brush.
 (2) Visually inspect for burned, bent, loose, corroded, or otherwise damaged terminals. Inspect wiring for breaks, loose connections, or other obvious damage. Tighten loose connections, replace damaged terminals, and replace damaged wiring. Touch up paint according to TB 43-0144.

4-7.2.8.2 Repair

- a. Removal. Remove cooling pump from mounting according to the following procedures:

WARNING

Make sure cooling pump motor is electrically dead before starting repairs. Redtag power panel circuit breaker 1P5 and controller main switch with: "WARNING - DO NOT ACTIVATE. REPAIRS BEING MADE."

- (1) Open power panel 1 circuit breaker 1P5 and open controller main switch (Figure 3-1).
 (2) Close cooling pump supply valve SW27 and discharge valve SW47. On Barges 2 and 3, also close valve SW28.
 (3) Tag and disconnect electrical wiring.
 (4) Disconnect all piping to pump assembly and allow water to drain to bilge.
 (5) Remove mounting bolts and remove pump assembly

- b. Disassembly and repair of cooling pump. Disassemble and repair cooling pump according to Aurora Pumps Instruction Manual In Appendix B. Use repair parts listed in Appendix G of TM 55-1930-209-14 & P-18.
- c. Reinstallation of cooling pump. Reinstall cooling pump according to following procedures:
 - (1) Reinstall pump assembly and tighten mounting bolts.
 - (2) Connect all piping.
 - (3) Connect electrical wiring.
 - (4) Energize cooling pump motor controller by closing power panel 1 circuit breaker 1P5. Close main switch on motor controller. Remove red tags.
 - (5) Open valves SW27, SW28 (Barges 2 and 3 only), and SW47. Make sure valve SW3 is open and seawater strainer 3 is not clogged.
 - (6) Momentarily start cooling pump and listen for pump moving water. If pump is moving water, repair is complete. Make appropriate entry in maintenance records. If pump is not moving water within 30 seconds, turn off pump and troubleshoot.

4-7.2.8.3 Replacement

- a. Removal.
 - (1) Close seawater valves SW27 and SW47. On Barges 2 and 3, also close valve SW28.
 - (2) Tag and disconnect wiring from motor.
 - (3) Disconnect piping from pump.
 - (4) Remove hardware securing pump assembly to foundation.
 - (5) Remove pump assembly.
- b. Installation. Install pump assembly in reverse order of removal in step a.

4-7.2.9 Pressure regulator (chlorination unit seawater supply line)

4-7.2.9.1 Cleaning and inspection

- a. Wipe clean exterior of pressure regulator with rag dampened with hot soapy water or an approved solvent. Wipe dry with clean cloth.
- b. Visually inspect for damage or leaks. Correct leak by tightening connection. Replace damaged regulator.

4-7.2.9.2 Replacement

- a. Removal.
 - (1) If chlorination unit valve CU11 is in position A, turn to position C. If chlorination unit valve CU11 is in position B, leave in that position.
 - (2) Close seawater valves SW47 and SW48.
 - (3) Remove pressure regulator.
- b. Installation. Install pressure regulator in reverse order of removal in step a.

4-7.2.10 Pressure gauge (chlorination unit seawater supply line)

4-7.2.10.1 Cleaning and inspection

- a. Wipe clean exterior of pressure gauge with rag dampened with hot soapy water or an approved solvent. Wipe dry with clean cloth.
- b. Visually inspect for damage or leaks. Correct leak by tightening connections. Replace damaged pressure gauge.

4-7.2.10.2 Replacement

- a. Removal.
 - (1) If chlorination unit valve CU11 is in position A, turn to position C. If chlorination unit valve CU11 is in position B, leave in that position.
 - (2) Close seawater valves SW47 and SW48.
 - (3) Remove pressure gauge.
- b. Installation. Install pressure gauge in reverse order of installation.

4-7.2.11 Seawater to chlorination In-line filter 3 (chlorination unit seawater supply line)**4-7.2.11.1 Cleaning and Inspection**

- a. Wipe clean exterior of filter (Figure 1-5) with rag dampened with hot soapy water or an approved solvent. Wipe dry with clean cloth.
- b. Visually inspect for damage or leaks. Correct leak by tightening connections. Replace damaged filter assembly. Replace filter element when pressure gauge pressure drops from 10 psi to about 8 psi.

4-7.2.11.2 Filter element replacement. When pressure gauge adjacent to filter drops in pressure from 10 psi to about 8 psi, replace filter element as follows:

- a. If chlorination unit valve CU11 is in position A, turn to position C. If chlorination unit valve CU11 is in position B, leave in that position.
- b. Close seawater valves SW47 and SW48.
- c. Use in-line hose bib to drain excess water from line, then close hose bib.
- d. Unscrew filter body and drain. Clean and replace filter element.
- e. Replace filter body to housing

4-7.2.11.3 Filter assembly replacement

- a. Removal.
 - (1) Perform steps a thru d.
 - (2) Disconnect piping from filter assembly.
 - (3) Remove filter assembly.
- b. Installation. Install filter assembly in reverse order of removal in step a.

4-7.2.12 Seachest and ballast tank air escape valve

4-7.2.12.1 Repair

- a. On face of valve located on top of deckhouse, remove three cap screws holding cap in place.
- b. Carefully remove cap, protective mesh, space ring, and flame screen from valve body.
- c. Clean all these components with soap and water using a stiff brush if necessary.
- d. Visually inspect parts for damage and replace damaged parts.
- e. Install parts in air escape body in reverse order of removal. Tighten three cap screws holding cap in place.

4-7.2.12.2 Replacement

- a. Removal. Burn off ballast tank escape valve and unscrew seachest escape valve.
- b. Installation. Weld on new ballast tank escape valve and screw on new seachest escape valve.

4-7.2.13 Generator cooling inlet and outlet temperature gauges

4-7.2.13.1 Cleaning and inspection

- a. Wipe clean temperature gauges listed below with rag dampened with hot soapy water or an approved solvent. Wipe dry with clean cloth.

<u>TEMPERATURE GAUGE LOCATION</u>	<u>GENERATOR BEING COOLED</u>
Void 4 port	Service generator 1
Void 4 starboard	Service generator 2
Void 4 starboard	Auxiliary generator 3

- b. Visually Inspect for damage or leaks. Correct leak by tightening connections. Replace damaged gauge.

4-7.2.13.2 Replacement

- a. Removal. Close following seawater valves as necessary:

<u>VALVE</u>	<u>VALVE LOCATION</u>
SW38 or SW39	Void 4 port (Service generator 1)
SW40 or SW41	Void 4 starboard (Service generator 2)
SW42 or SW43	Void 4 starboard (Auxiliary generator 3)

- b. Installation. Install temperature gauge in reverse order of installation in step a.

4-7.2.14 Ballast tank. Repair ballast tank when leak is noted at access plate as follows:

- a. Empty ballast tank as given in paragraph 3-3.6.
- b. Remove 24 screws attaching access plate with synthetic rubber gasket.
- c. Remove access plate with gasket.
- d. Remove gasket from access plate.
- e. Clean tank exterior and access plate gasket mating surface.
- f. Install access plate with new gasket.
- g. Secure access plate with 24 screws.
- h. Touch up paint in accordance with TB 43-0144.
- i. Check for leaks when tank is full.

4-7.2.15 Ballast tank liquid level Indicator

4-7.2.15.1 Cleaning and inspection

WARNING

Make sure equipment monitoring system is off before starting cleaning and inspection.

- a. Clean tank liquid level indicator connections and equipment monitoring system connections by vacuuming or cleaning with electrician's brush.
- b. Visually inspect for corrosion, loose connections, or damaged wiring. Clean corrosion, tighten loose connections, and replace damaged wiring.

4-7.2.15.2 Test

WARNING

Make sure equipment monitoring system is off before performing continuity check.

- a. Check continuity between sensor and monitoring system main processor. If continuity test indicates a closed circuit, perform sensor test in steps b thru e. If continuity test indicates an open circuit, clean, inspect, and repair as given in paragraph 4-7.2.15.1.

NOTE

Storage tank liquid level indicator test is to be performed using the equipment discussed in TM 55-1930-209-14 & P-11. This procedure is to be used when sensor readings are onscale and stable but are inaccurate.

- b. Check level indicated on visual flag level indicator. If level does not agree with monitor display page (Figure 3-3), go to step c.
- c. Select EDIT MENU option 1 to activate sensors as given in paragraph 3-6.2 in TM 55-1930-209-14&P-11.
- d. Check that the following span reference value as shown on Drawing 23285 in Appendix B and the value for drinking water tanks shown on the edit page agree.

<u>SCALE IN</u>	<u>OFFSET</u>	<u>SPAN</u>	<u>RANGE</u>	<u>CALIBRATION</u>
120	0	1832	0	6
107	0	1962	0	6
86	0	2255	0	6

- e. Calibrate sensor by calculating new offset using the following equation:

$$\left[\frac{(\text{Actual Reading} - \text{Displayed Reading}) \times 3840}{\text{Full Scale}} \right] + \text{Old Offset}$$

- f. Repeat calculation until monitor screen value is within ± 1 percent of desired reading.
- g. If desired reading cannot be obtained, notify shift leader or bargemaster that liquid level indicator ROLI transmitter must be replaced and that IGS should be notified.

4-7.2.15.3 Replacement

- a. Removal.
 - (1) Empty ballast tank as given in paragraph 3-6.2.
 - (2) Tag and disconnect all electrical wires.
 - (3) Disconnect two pipe unions connecting liquid level indicator to tank. Remove indicator.
 - (4) Remove liquid level indicator.
- b. Disassembly and repair.
 - (1) Unclamp ROLI transmitter.
 - (2) Unclamp flag channel assembly from casing.
 - (3) Remove top and bottom end caps and remove float assembly from inside of casing. Flush clean inside of casing with drinking water and wipe clean float assembly.
 - (4) Wipe clean flag channel assembly.
 - (5) Reinstall new ROLI transmitter, visual flag channel assembly, and switches as necessary. Orient parts as shown in Transamerica Delaval Drawing No. 87707 in Appendix B.
- c. Installation.
 - (1) Install liquid level indicator with two unions to tank.
 - (2) Connect all electrical wires tagged previously.
 - (3) Refill tank and recalibrate liquid level sensor as given in paragraph 4-7.2.15.1.

4-7.2.16 Piping and valves. Replace piping or valves, or repack worn or damaged valves according to procedures in TM 55-503.

CHAPTER 5 STORAGE

5-1 Short-term storage. If barge is to be taken out of service for more than 7 days but less than 30 days, and seawater system will not be used while in storage, follow normal shutdown procedures in paragraph 3-4. Inspections are not required for this system during short-term storage.

5-2 Administrative storage. If barge is to be taken out of service for more than 30 days but less than 6 months, barge remains a unit responsibility and shall be maintained by unit personnel.

5-2.1 Administrative storage procedures, generators in use. If barge is placed in administrative in-water storage, with generators in use, seawater system will be processed as follows:

NOTE

Valve numbers referred to in following procedures are the same as shown in Figures 1-3 and 1-4 for ROWPU and ballast seawater supply, Figures 1-5 and 1-1 for air conditioner and seawater cooling and Figures 1-6, 1-7, and 1-8 for diesel engine generator seawater cooling.

- a. Make sure barge is at desired trim. If not, follow procedures in paragraphs 3-3.5 and 3-3.6 to obtain desired trim.
- b. Shutdown seawater supply to ROWPU's by following procedures in paragraph 3-4.1.
- c. Shutdown seawater supply to chlorination and air conditioning units by following procedures in paragraph 3-4.3.
- d. Open switchboard circuit breakers P6 and P7.
- e. Open power panel 1 circuit breaker 1P5.
- f. Make sure valves SW1 thru SW4, SW18, and SW26 are closed.
- g. Open all remaining seawater system valves; SW5 thru SW13, SW16 thru SW36, SW47, and SW48.
 - h. Open pipes at lowest point and drain into bilge.
 - i. Clean glass pressure gauges and indicators with a clean, lint-free cloth.
 - j. Clean grease coated surfaces with a clean, lint-free cloth moistened with cleaning solvent. Scrub off hard deposits with a bristle brush that has been dipped in solvent. Dry surfaces with a clean, lint-free cloth.
 - k. Thoroughly clean all other external surfaces to remove any corrosion or other foreign matter. Clean all surfaces except electrical parts with soapy water and a stiff bristle brush. Then flush with clean water. Clean motor controllers and remote START/STOP switches by wiping with a clean cloth moistened with silicone spray lubricant. Remove corrosion by wire brushing or sanding.
 - l. Touch up paint, as necessary, to match surrounding areas (TB 43-0144). Do not paint threads or labels.

5-2.2 Administrative storage procedures, generators off. If barge will be placed in administrative in-water storage, with generators inactivated, seawater system shall be processed as required in paragraph 5-2.1 with these additional procedures:

- a. Make sure generators are inactivated in accordance with procedures in TM 55-1930-209-14 & P-9.
- b. Close valves SW37 and SW49.
- c. Open valves SW38 thru SW46.
- d. Open pipes at lowest point and drain into bilge.

5-2.3 Administrative storage inspection. When barge is in storage, seawater system shall be inspected at least every 30 days. Check for corrosion, damage, and pilferage. Correct as necessary.

5-3 Long-term storage. If barge is to be taken out of service for 6 months or more, turn it in to depot for preparation and placement into long-term storage. If barge is in administrative storage and is to be taken out of service and placed in depot long-term storage (6 months or more), process seawater system for normal operations as specified below before releasing to depot

- a. Perform before operation checks in Appendix C.
- b. Check that seawater system operates satisfactorily while performing procedures in Chapter 3, Section III.
- c. Perform during operation checks in Appendix C.
- d. Upon successful completion of Inspection, including after operation checks, release seawater system to depot for long-term storage.

CHAPTER 6 MANUFACTURERS' SERVICE MANUALS/INSTRUCTIONS

6-1 General. The manufacturers' service manuals/instructions listed below provide additional information on components of the seawater system. A copy of each manual/set of instructions is contained in Appendix B. It may be necessary to refer to both these manuals/instructions and to drawings listed in Appendix A while performing the procedures in this TM.

<u>Component</u>	<u>Document title</u>	<u>Manufacturer</u>
Seawater pump size 2x4x9 TC-30	Repair instructions for Turbocraft Single Stage Centrifugal Pumps	Hydraunautic 6338 Lindnar Drive Goleta, CA 9301
Duplex Strainer Series No 50	Hayward Duplex Strainers Model 50	Hayward Industrial Products Inc. 900 Fairmont Ave. Elizabeth, NJ 07207 (201) 351- 5400
Cooling pump, series 321, M1X1-1/2X6	Aurora Pumps Instruction Manual, Model 321	Aurora Pump 800 Airport Road North Aurora, IL 60542 (312) 859-7600
Lakos separator	L-FD Industrial Service Separators	Claude Laval Corp. 1911 N Helm Fresno, CA 93703 (209) 255-1601
Tank air escape valve type 1600T and 1600W	Tank Air Escape Valves, Model 1600	Robert H Wager Co, Inc. Passaic Avenue Chatham, NJ 07928 (201) 635-9200
Sure site day tank liquid level indicator part no. 86210, type 2	Gems Liquid Level Indicators Gems Sensors Division	Transamerica DeLaval Inc. Cowles Road Plainsville, CT 06062 Ph: (203) 677-1311
Storage tank liquid level indicator part no. 86615, Type C, w/ ROLI 4-10ma	Gems Liquid Level Indicators Dwg no. 87707, flag position	
Cooling pump motor controller	See Square D Class 8538 Combination Starter Catalog in TM 55-1930-209-14 & P-9	
Storage tank level sensor	Drawing No. 23285 Rev. A, Sensor Specifications; General, Gems Tank Level Sensor	Tracor Marcon, Inc. 13433 NE 20th Street Bellevue, WA 98005 Ph: (206) 643-0912

CHAPTER 7 MANUFACTURERS' WARRANTIES/GUARANTEES

7-1 General. Information on the warranty/guarantee for components of the seawater system is supplied below.

<u>Component</u>	<u>Manufacturer</u>	<u>Duration</u>	<u>Coverage</u>
Duplex strainer series no. 50	Hayward Industrial Products Inc. 900 Fairmont Ave Elizabeth, NJ 07207 Ph: (201) 351-5400	1 year from date of shipment	Material and workmanship
Cooling pump series 321, M1X 1-1/2X6	Aurora Pump 800 Airport Road North Aurora, IL 60542 Ph: (312) 859-7600	1 year from date of purchase	Material and workmanship
Lakos separator L-4042-FD-SC	Claude Laval Corp. 1911 N. Helm Fresno, CA 93703 Ph: (209) 255-1601	1 year from date of delivery	Material and workmanship
Tank air escape valve 1600T	Robert H. Wager Co., Inc Passaic Avenue Chatham, NJ 07928 Ph: (201) 635-9200	1 year from date of purchase	Material and workmanship
Sure site day tank liquid level indicator part no. 86210, type 2	Transamerica DeLaval Gems Sensors Division Cowles Road Plainsville, CT 06062 Ph: (203) 677-1311	1 year from date of purchase	Material and workmanship
Storage tank liquid level indicator part no. 86615, type C w/ ROLI 4-10ma			
Cooling pump motor Electrical Power Systems	See TM 55-1930-209-14&P-9		

APPENDIX A

REFERENCES

A-1 Drawings

US Army Belvoir Research, Development and Engineering Center (97403)

13226E1892	ROWPU/Barge Arrangement
13226E1893	List of Label Plates
13226E1898	Seawater System
13226E1899	Seawater System Operational Instruction Placard
13226E1900	ROWPU Installation
13226E1904	ROWPU Operational Instruction Placard
13226E1911	Generators Cooling System
13226E1920	Compressed Air System
13226E1921	Compressed Air System Operational Instruction Placard
13226E1928	Alarm/Casualty Monitoring System
13226E1932	Electrical Power Schematic Diagram
13226E1933	Communication System
13226E1935	Electrical Power System Layout
13226E1939	Motor Controllers Schematic and Wiring Diagram
13226E1942	Ballast System
13226E1944	Equipment Shut Down System
13226E1952	Multimedia Filter Assembly (Barge 1 only)
13226E1953	Tank, Multimedia Filter (Barge 1 only)
13226E1954	Plate, Information Multimedia Filter (Barge 1 only)
13226E1955	Distributor Assy, Bottom, Multimedia Filter (Barge 1 only)

A-2 Painting

TB 43-0144	Painting of Vessels
------------	---------------------

A-3 Demolition To Prevent Enemy Use

TM 750-244-3	Procedures for Destruction of Equipment to Prevent Enemy Use
--------------	--

A-4 Maintenance

DA PAM 738-750	The Army Maintenance Management System (TAMMS)
TM 55-503	Marine Salvage and Hull Repair

APPENDIX B

MANUFACTURERS' SERVICE MANUALS/INSTRUCTIONS

<u>Component</u>	<u>Document title</u>	<u>Manufacturer</u>
Duplex Strainer Series No. 50	Hayward Duplex Strainers Model 50	Hayward Industrial Products Inc 900 Fairmont Avenue Elizabeth, NJ 07207 (201) 351-5400
Cooling pump, series 321, M1X1-1/2x6	Aurora Pumps Instruction Manual, Model 321	Aurora Pump 800 Airport Road North Aurora, IL 60542 (312) 859-7600
Lakos separator	L-FD Industrial Service Separators	Claude Laval Corp 1911 N Helm Fresno, CA 93703 (209) 255-1601
Tank air escape valve type 1600T and 1600W	Tank Air Escape Valves, Model 1600	Robert H. Wager Co., Inc. Passaic Avenue Chatham, NJ 07928 (201) 635-9200
Sure site day tank liquid level indicator part No. 86210, type 2	Gems Liquid Level Indicators	Transamerica DeLaval Inc. Gems Sensors Division Cowles Road Plainsville, CT 06062 (203) 677-1311
Storage tank liquid level indicator part No 86615, Type C, w/ROLI 4-10ma	Gems Liquid Level Indicators Dwg No. 87707, flag position	
Storage tank level sensor	Drawing No. 23285 Rev A, Sensor Specifications, General, Gems Tank Level Sensor	Tracor Marcon, Inc 13433 NE 20th Street Bellevue, WA 98005 (206) 643-0912
Cooling pump motor controller	See Square D Class 8538 Combination Starter Catalog in TM 55-1930-209-14&P-9	

APPENDIX C

Preventive maintenance checks and services (PMCS) for Seawater System

C-1 Introduction to PMCS

NOTE

TM 55-1930-209-14&P-19 contains PMCS for all systems on the ROWPU Barge. This appendix contains only PMCS for the Seawater System

a. General.

- (1) Systematic (B) before, (D) during, (A) after, and scheduled periodic PMCS are essential to ensure that the Reverse Osmosis Water Purification Barge is in operational readiness at all times. The purpose of the PMCS program is to discover and correct deficiencies and malfunctions before they cause serious damage or failure of the barges and their support systems. An effective PMCS program requires that operators report all unusual conditions noticed before, during and after operation as well as while performing periodic PMCS. All deficiencies and malfunctions discovered during maintenance inspections must be recorded, together with the corrective action taken, on DA Form 2404 (Equipment Inspection and Maintenance Worksheet).
- (2) A schedule for preventive maintenance inspections and service should be established and adhered to. When operating under unusual conditions, such as extreme heat or cold, it may be necessary to perform PMCS more frequently.
- (3) The PMCS items have been arranged and numbered in a logical sequence to provide for greater efficiency and the least amount of downtime required for maintenance.

b. PMCS columnar entries.

- (1) Item Number Column. Checks and services are numbered in chronological order regardless of interval. This column is used as a source of item numbers for the "Item Number" column on DA Form 2404, Equipment Inspection and Maintenance Worksheet, in recording results of PMCS.
- (2) Interval Column. The interval columns tell you when to do a certain check or service: before, during, or after operation. Sometimes a dot may be placed in more than one interval column which would mean you should do the check or service at each of those intervals.
- (3) Item to Be Inspected Column. This column lists the common name of the item to be inspected such as "Air Filters."
- (4) Procedures Column. This column tells you how to do the required checks and services. Carefully follow these instructions.
- (5) Equipment is Not Ready/Available if Column. This column tells you when and why your equipment cannot be used.

NOTE

The terms "Ready/Available" and "Mission Capable" refer to the same status: equipment is on hand and is able to perform its combat missions. (See DA PAM 738-750).

- (6) Increased Inspections. Perform weekly as well as Before Operations PMCS if:
 - (a) You are the assigned operator and have not operated the item since the last weekly PMCS.
 - (b) You are operating the item for the first time.
- (7) Leakage definitions. In checking for fluid leaks, the following leakage definitions apply to all ROWPU barges and barge equipment, product water, and seawater leakage by class type.

- (a) Class I - Seepage of fluid (as indicated by wetness or discoloration) not great enough to form drops.
- (b) Class II - Leakage of fluid great enough to form drops, but not enough to cause drops to drip from the item being checked/inspected.
- (c) Class III - Leakage of fluid great enough to form drops that fall from the item being checked/inspected.

CAUTION

Equipment operation is allowable with minor leakages (Class I or II). However, the fluid level or operating pressure of the item being checked/inspected must be considered. When in doubt, notify the shift leader or bargemaster.

When operating with Class I or Class II leaks, continue to check fluid levels as required by PMCS and operating instructions.

- (8) The following fuel and hazardous material leakage procedures apply for any fuel, chemical, or bilge system.

WARNING

Class I, II or III leaks or seepage occurring in a fuel, chemical, or bilge container, tank, line, piping, or valve can cause fire or health hazards.

- (a) If any leaks or seepage from a fuel, chemical, or bilge container, tank, or fluid line is detected, it must be immediately reported to the shift leader or bargemaster for corrective action.
- (b) To prevent combustible or toxic fumes from collecting or contaminated material from spilling, exercise extreme caution after detecting leaks or seepage of flammable or hazardous material.
- c. Continuous operation. When equipment must be kept in continuous operation for extended periods of time, check and service only those items that can be checked and serviced without disturbing operations. Perform complete checks and services when the equipment can be shut down.
- d. Maintenance log. Always record the time and date of PMCS, any deficiencies noted, and corrective action taken in the PMCS log book.

C-2 Major components. The seawater system consists of the Reverse Osmosis Water Purification Unit (ROWPU) and ballast seawater supply, the air conditioner cooling and chlorination unit seawater supply, and the diesel engine generator cooling and seawater supply. System components include; seachests, seawater strainers, pressure gauges and regulators, seawater filters, pumps, water supply, ballast and chemical tanks, piping, valves, and associated electrical circuitry and control panels. Tables NO TAG through NO TAG list the major components of the seawater system, their basic function and location on the barge.

C-3 Seawater system description. The seawater system supplies seawater to the ROWPUs for processing, to the air conditioning unit for cooling, to the ballast tank (Figures C-1 and C-2) for barge trimming, to the chlorination unit for priming and cooling (Figure C-3 and C-4), and to the diesel generators (Figures C-5 and C-6) for cooling. There are three sources for supplying seawater; a forward seachest in void 2 starboard, a shell penetration in void 2 starboard and an aft seachest in void 4 port. The seachest in void 2 starboard supplies sufficient seawater to ROWPUs for processing when the barge is anchored in 15 feet or more of water. When anchored in from 10 to 15 feet of water, the starboard shell intake supplies sufficient seawater to ROWPUs for processing. When the barge is anchored or is pierside, seachest in void 2 starboard can be used to supply seawater for the air conditioner and the chlorination unit. Also, when the barge is anchored or pierside, the seachest in void 4 port can be used to supply seawater for cooling diesel generators.

Table C-1. Preventive Maintenance Checks and Services for Seawater System

B - Before
D - During
A - After

D - Daily
W - Weekly
M - Monthly

Q - Quarterly
S - Semiannually
A - Annually

ITEM NO.	INTERVAL										ITEM TO BE INSPECTED	PROCEDURES CHECK FOR AND HAVE REPAIRED OR ADJUSTED AS NECESSARY	EQUIPMENT IS NOT READY/ AVAILABLE IF
	B	D	A	D	W	M	Q	S	A				
											SEAWATER SYSTEM	<p>WARNINGS</p> <p>Be sure electrical power is OFF before performing any maintenance or repair on this system. OPEN circuit breakers. Redtag circuit breakers or motor controller with "WARNING - DO NOT ACTIVATE. REPAIRS BEING MADE." Observe safety precautions listed at the beginning of this manual and in manufacturers' manuals/instructions. High voltages and hazardous materials are used in the operation of this equipment The power supply to the equipment must be shut off before performing PMCS.</p> <p>NOTE</p> <p>Open (OFF) switchboard circuit breakers:</p> <ul style="list-style-type: none"> a. ROWPU 1 and 2 control station-switchboard circuit breakers P6 and P7 are open (OFF) b. Cooling pump controller-power panel 1 circuit breaker 1P5 is open (OFF) 	
1	•		•	•	•						All Components	<ul style="list-style-type: none"> a. Wipe components clean, especially gauges and control panels (void 2 starboard) b. Check for leaks, paying special attention to all joints, valves, fittings and piping Report leaks to shift leader or bargemaster for corrective action c. Check for damage, especially to pressure gauges, filters and control panels 	<p>Class III leaks.</p> <p>Pressure gauge inoperable</p>

Table C-1. Preventive Maintenance Checks and Services for Seawater System (Continued)

B - Before
 D - During
 A - After
 D - Daily
 W - Weekly
 M - Monthly
 Q - Quarterly
 S - Semiannually
 A - Annually

ITEM NO.	INTERVAL										ITEM TO BE INSPECTED	PROCEDURES CHECK FOR AND HAVE REPAIRED OR ADJUSTED AS NECESSARY	EQUIPMENT IS NOT READY/ AVAILABLE IF
	B	D	A	D	W	M	Q	S	A				
2	•		•	•							Wiring	d. Check for loose or missing securements and fasteners. Tighten and replace as necessary.	Securements and/or fasteners loose or missing.
	•			•								a. Check wiring for loose connections and frayed cables. Secure as necessary. Repair or replace damaged cables using insulated tools	Cables frayed.
			•										b. Visually check wiring for loose connections. If sparks are visible, immediately stop operation and report to shift leader or bargemaster.
3	•	•		•							Seawater Strainer	a. Ensure that seawater strainer baskets (void 2 port and starboard) are dean and properly installed.	
				•								b. Change flow, remove and clean, or replace as follows. 1) To change flow. <ul style="list-style-type: none"> • Loosen diverter plug locking flange by turning locking T-bolt handle/ handlewheel counterclockwise. • Turn handle toward clean basket until it stops. <p style="text-align: center;">CAUTION Never operate strainer with diverter plug unseated. Sediment may collect under plug and prevent a tight seal causing damage to equipment.</p> <ul style="list-style-type: none"> • Tighten locking flange by turning locking T-bolt handle/handlewheel clockwise to seat diverter plug. Do not overtighten. 2) To remove and clean seawater basket: <ul style="list-style-type: none"> • Loosen yoke screw until yoke swings free. 	

Table C-1. Preventive Maintenance Checks and Services for Seawater System (Continued)

B - Before
D - During
A - After

D - Daily
W - Weekly
M - Monthly

Q - Quarterly
S - Semiannually
A - Annually

ITEM NO.	INTERVAL										ITEM TO BE INSPECTED	PROCEDURES CHECK FOR AND HAVE REPAIRED OR ADJUSTED AS NECESSARY	EQUIPMENT IS NOT READY/ AVAILABLE IF
	B	D	A	D	W	M	Q	S	A				
												<ul style="list-style-type: none"> • Pull basket handle straight up to remove basket <p style="text-align: center;">CAUTIONS</p> <p>Do NOT leave basket well open for more than 10 minutes. Diverter plug does not completely cut off water and water will seep into open well.</p> <p>Do NOT use any petroleum based products to clean basket Be careful not to damage basket Do not use wire brush.</p> <ul style="list-style-type: none"> • Clean basket on weatherdeck with soft brush and flush with drinking water. <p style="text-align: center;">WARNINGS</p> <p>DO NOT use compressed air to clean clothing or work space. High pressure (HP) air turns small particles into dangerous projectiles that may injure people.</p> <p>When using compressed air to clean equipment, ALWAYS use protective shield to protect eyes and face from flying particles. Wear gloves and avoid skin damage by closing buttons and collars and rolling down shirt sleeves on work clothing.</p> <ul style="list-style-type: none"> • Use compressed air to discharge difficult particles • Flush with drinking water • Wipe interior of basket with dean cloth before reinstalling <p>3) To replace strainer basket</p> <ul style="list-style-type: none"> • Lower cleaned or new basket into well • Swing yoke over basket well until end fits over stud 	

Table C-1. Preventive Maintenance Checks and Services for Seawater System (Continued)

B - Before
 D - During
 A - After
 D - Daily
 W - Weekly
 M - Monthly
 Q - Quarterly
 S - Semiannually
 A - Annually

ITEM NO.	INTERVAL										ITEM TO BE INSPECTED	PROCEDURES CHECK FOR AND HAVE REPAIRED OR ADJUSTED AS NECESSARY	EQUIPMENT IS NOT READY/ AVAILABLE IF
	B	D	A	D	W	M	Q	S	A				
4	•	•		•							Seawater Pumps	<ul style="list-style-type: none"> • Be sure O-rings on cover rest in machined grooves before tightening yoke screw securely Do not overtighten. <p>c. Lubricate seawater pump motors and fittings, if necessary, with grease as specified In manufacturer's manual</p> <p>d. Be alert for unusual equipment noises, smells or overheating that might indicate pending equipment or system malfunction</p> <p>a. When using seawater pumps 1 and 2 (void 2 starboard).</p> <ol style="list-style-type: none"> 1) Check seawater system components for normal operation and for leaks 2) Inspect mounting bolts 3) Regularly monitor seawater strainer input and output pressure gauges for: <ul style="list-style-type: none"> • A pressure difference of 2-4 Hg between the pressure gauges is normal • If the pressure difference reaches 8 Hg, turn handle on strainer to route seawater flow through clean strainer basket. • Remove and clean dirty strainer basket 	<p>O-ring damaged or missing</p> <p>Class III leaks</p>
5	•	•		•							Seawater Filters	<p>b. Check gauges and tubing for cracks or leakage</p> <p>a. Drain seawater filters as follows:</p> <p style="text-align: center;">NOTE</p> <p>Drain only filter(s) In active use. If only one ROWPU system is In use with Just one seawater pump, then drain only filter(s) In use.</p> <p style="text-align: center;"><u>Clean Water Operations</u> Drain filter 15 seconds every 8 hours</p>	<p>Class III leaks</p>

Table C-1. Preventive Maintenance Checks and Services for Seawater System (Continued)

B - Before
 D - During
 A - After
 D - Daily
 W - Weekly
 M - Monthly
 Q - Quarterly
 S - Semiannually
 A - Annually

ITEM NO.	INTERVAL										ITEM TO BE INSPECTED	PROCEDURES CHECK FOR AND HAVE REPAIRED OR ADJUSTED AS NECESSARY	EQUIPMENT IS NOT READY/ AVAILABLE IF								
	B	D	A	D	W	M	Q	S	A												
6		•		•							Cooling Pump	<p><u>Dirty Water Operations</u></p> <p>Drain filter 15 seconds per each hour of operation.</p> <p>1) Drain seawater filters by:</p> <table border="0"> <tr> <td>Seawater Filter No</td> <td>Open seawater Valve No</td> </tr> <tr> <td>1</td> <td>22 and 26</td> </tr> <tr> <td>2</td> <td>23 and 26</td> </tr> <tr> <td>1 and 2</td> <td>22, 23 and 26</td> </tr> </table> <p>2) After draining, close valves SW22 and/or 23, and SW26</p> <p>3) Record time/date of purging in operations log</p> <p>a. While supplying seawater to air conditioning unit and/or chlorination system using cooling pump (void 2 port) perform the following:</p> <ol style="list-style-type: none"> 1) Check for normal operation and leaks 2) Check cooling water strainer input and output pressure gauges for normal operation <ul style="list-style-type: none"> • Pressure differences between the two reading gauges is normal. • If pressure difference between the two gauges reaches 2 HG, turn handle on the cooling water strainer to route the seawater flow through dean strainer basket • Remove and clean dirty strainer basket. • Record date/time of strainer basket change in operation log 3) When regulator outlet pressure gauge drops 10 psi, replace in-line filters 4) Inspect mounting bolts 	Seawater Filter No	Open seawater Valve No	1	22 and 26	2	23 and 26	1 and 2	22, 23 and 26	<p>Class III leaks</p> <p>Gauges inoperable</p>
Seawater Filter No	Open seawater Valve No																				
1	22 and 26																				
2	23 and 26																				
1 and 2	22, 23 and 26																				

Table C-1. Preventive Maintenance Checks and Services for Seawater System (Continued)

B - Before
 D - During
 A - After

D - Daily
 W - Weekly
 M - Monthly

Q - Quarterly
 S - Semiannually
 A - Annually

ITEM NO.	INTERVAL										ITEM TO BE INSPECTED	PROCEDURES CHECK FOR AND HAVE REPAIRED OR ADJUSTED AS NECESSARY	EQUIPMENT IS NOT READY/ AVAILABLE IF
	B	D	A	D	W	M	Q	S	A				
												<ul style="list-style-type: none"> If chlorination unit valve CU11 is In OPEN position, turn to CLOSE position Close seawater valves SW47 and SW48 Use in-line bib to drain excess water from line, then close hose bib Unscrew filter body and drain Clean or replace filter element. Replace filter body In housing. Return CU11 and SW47 and SW48 to OPEN. 	Class III leaks.
		•		•							<p>b. When supplying seawater for generator cooling,</p> <ol style="list-style-type: none"> 1) Check for normal operation and leaks 2) Regularly monitor generator cooling strainer input and output pressure gauges(void 4 port on barges 2 and 3 only). <ul style="list-style-type: none"> Pressure difference of 2-4 psi between the two groups is normal. If pressure differences between input and output gauges reaches 8 psi, turn handle on generator cooling system to route seawater through clean strainer. Remove and clean dirty strainer basket <p>c. Remove rust and corrosion. Touch up or paint in accordance with TB 43-0144 as necessary. Do not paint thread or labels.</p> <p>d. Lubricate air conditioning cooling pump motor and fittings, if necessary, with grease in each oil hole as specified in the manufacturer's manual.</p>		

Table C-1. Preventive Maintenance Checks and Services for Seawater System (Continued)

B - Before
 D - During
 A - After

D - Daily
 W - Weekly
 M - Monthly

Q - Quarterly
 S - Semiannually
 A - Annually

ITEM NO.	INTERVAL										ITEM TO BE INSPECTED	PROCEDURES CHECK FOR AND HAVE REPAIRED OR ADJUSTED AS NECESSARY	EQUIPMENT IS NOT READY/ AVAILABLE IF
	B	D	A	D	W	M	Q	S	A				
											<ul style="list-style-type: none"> Liquid Level Indicator 	<p>e. Flush liquid level indicator with drinking water as follows:</p> <ol style="list-style-type: none"> Empty seawater ballast tank Disconnect 2 pipe unions connecting indicator to tank Remove indicator. Flush indicator by allowing drinking water to flow into top pipe connector and out of bottom pipe connector Connect indicator to tank by tightening pipe unions Check for leaks and for indication on equipment monitoring system. Check visual flag indicator when ballast tank is refilled <p>f. If seawater source is high in debris perform BLOWDOWN as follows</p> <p style="text-align: center;">CAUTION</p> <p>During seachest blowdown, be sure regulator 2 pressure gauge reads 40 psi. Reset if necessary by turning adjusting screw.</p> <ol style="list-style-type: none"> <u>Prestart</u> <ul style="list-style-type: none"> Make sure air compressor is operating. If not, start up in accordance with air compressor system operation Check that compressed air pressure regulator 2 is set to 40 psi as shown on regulator gauge Make sure seachest is not in use. 	

Table C-1. Preventive Maintenance Checks and Services for Seawater System (Continued)

B - Before
 D - During
 A - After

D - Daily
 W - Weekly
 M - Monthly

Q - Quarterly
 S - Semiannually
 A - Annually

ITEM NO.	INTERVAL										ITEM TO BE INSPECTED	PROCEDURES CHECK FOR AND HAVE REPAIRED OR ADJUSTED AS NECESSARY	EQUIPMENT IS NOT READY/ AVAILABLE IF
	B	D	A	D	W	M	Q	S	A				
												2) Operation <ul style="list-style-type: none"> • Close seawater (SW) valves SW11, SW2 and SW3 • Turn valve SW30 to position C, SEACHEST. • When regulator gauge reading stabilizes at 3-5 psi, turn valve SW30 to position A - VENT. <p style="text-align: center;">NOTE</p> <p>If seachest obstruction is not cleared, repeat BLOWDOWN procedures.</p> <p style="text-align: center;">WARNING</p> <p>Do not open seachest unless valve SW30 is in position A - VENT.</p>	

Hayward® Duplex Strainers

Sizes from 3/4" to 8"

Model 50

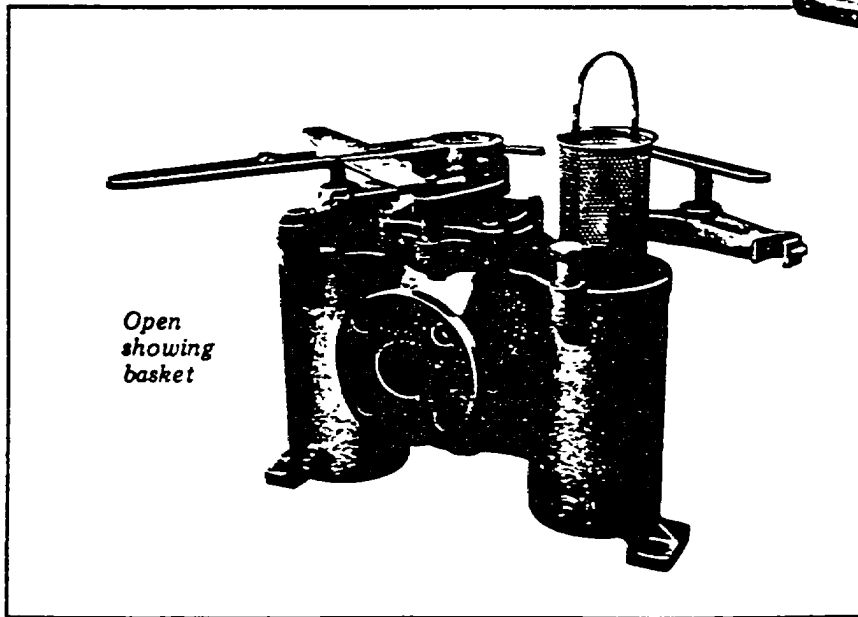
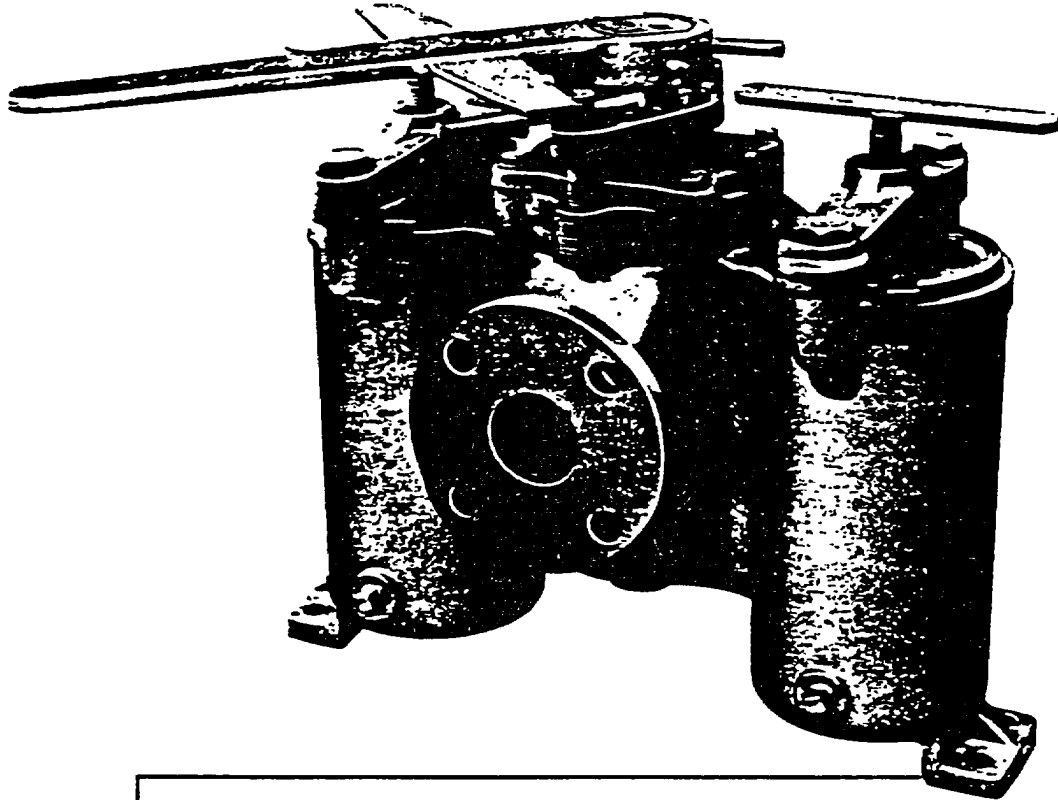

Hayward®

Model

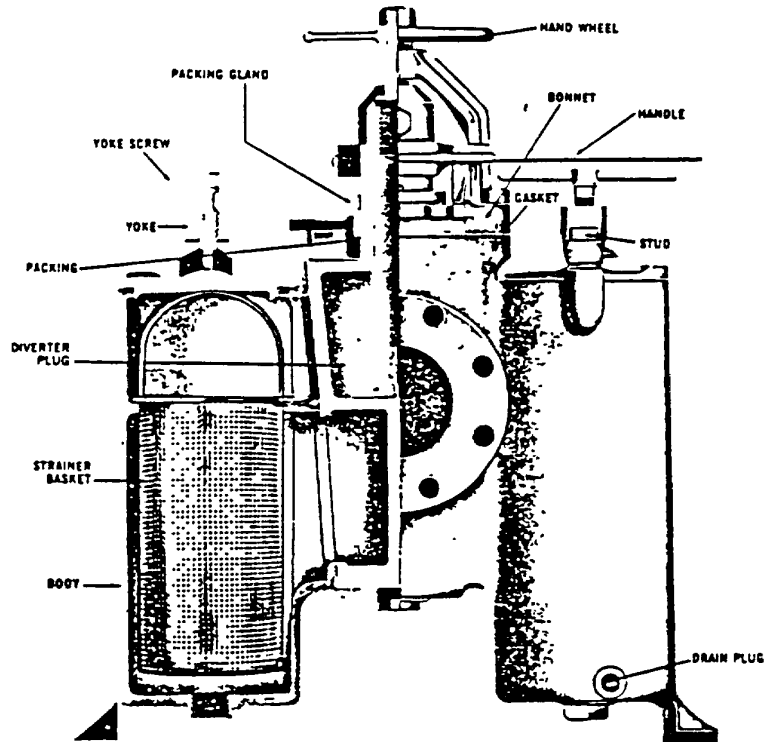

Type	All Wetted Parts	Exterior Trim	Baskets	Cover Gaskets	Stem Packing
Iron	ASTM A-48 Class 30 bodies, bonnets and covers. Bronze Diverter Plug	Ductile iron	Brass, SS or Monel	Buna-N	Buna-N
Bronze	ASTM B-62 valve bronze	Ductile iron	Brass, SS or Monel	Buna-N	Buna-N
Stainless Steel	ASTM A-296 Grade CF-8M Type 316	Ductile iron	SS or Monel	Viton-A	Viton-A
Carbon Steel	ASTM A-216 Grade WCB carbon steel, Bronze Diverter Plug	Ductile iron	SS or Monel	Buna-N	Buna-N
Material	Pressure Rating*	End Connections			
		Screwed	Flanged		
Iron	200 psi WOG	NPT Threads	125 lbs. ANSI Dimensions		
Bronze	200 psi WOG	NPT Threads	150 lbs. ANSI Dimensions		
Stainless Steel	200 psi WOG	NPT Threads	150 lbs. MSS Dimensions		
Carbon Steel	200 psi WOG *At 75°F	NPT Threads	150 lbs. ANSI Dimensions		

Materials shown are standard.

Hayward[®]

Model

Sizes from 3/4" to 8"

Available in Iron, Bronze, Stainless,
Carbon Steel.

For flow rates up to 1000 gpm.

For sizes up to 8" we use the time tested tapered plug principle. It is the simplest, most economical and trouble-free design for a duplex basket strainer in smaller sizes. Several hundred thousand Hayward strainers of this type have been sold and installed during the past fifty years and almost all of them are still in service.

This type of unit is actually a high quality, pressure rated plug valve with integral strainers. Switching flow is accomplished by moving the handle through a 90 degree arc. It is impossible for this operation to stop the flow because of the unique port design in the diverter plug. Hayward duplex strainers are tight. Every one is hydrostatically tested at 1½ times its maximum rated pressure.

The high ratio of free straining area to the cross-sectional pipe area results in low pressure drop and unusually large straining capacity.

Tightness is assured by careful matching of each diverter plug to its mating body. An adjustable packing gland and high grade stem packing permit compensation to take care of wear, etc. With reasonably proper maintenance, Hayward strainers will remain tight almost indefinitely.

The 4", 5", 6" and 8" models have a lifting jack to make switching baskets easier. A few turns of the handwheel lift the diverter plug off its seat very slightly. After it has been rotated, the handwheel is turned back and the plug is re-seated. This locks it into place and prevents leakage.

On sizes up to and including 3", the plug is firmly seated by a locking flange. It can be tightened or loosened with our sliding bolt handles. No tools are needed — (*The whole basket switching operation takes less than 30 seconds*). All Hayward duplex strainer handles are removable, insuring tamper-proof operation if this is desired.

If desired, the same lifting jack and handwheel features as supplied on the larger models are also available as optional extras for the smaller units up to 3".

The cover features our quick opening, swing away, yoke

Hayward®

Model

design. No tools needed, just a pair of hands to open and remove the basket in seconds. Each basket compartment has both a side and a bottom drain outlet (fitted with plugs). All strainers are provided with legs for bolting to the floor. Basket seats are precision machined to give a tight, positive seal, eliminating the possibility of any material by-passing the basket.

The diverter plugs in Hayward Duplex Strainers are used only for the diversion of flow. While they are built to stand the full rated pressure of the strainer, they cannot be depended upon for dead-tight shutoff.

A general criterion of tightness is that it should take at least 20 minutes to fill the basket well.

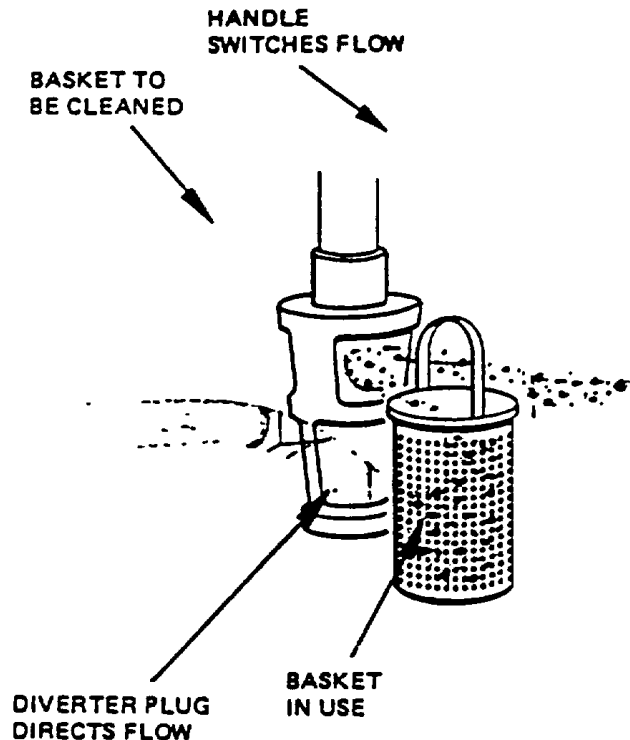

Hayward®

Model

Dimensions

Flanged

Pipe Sizes: 2" - 2½" - 3"

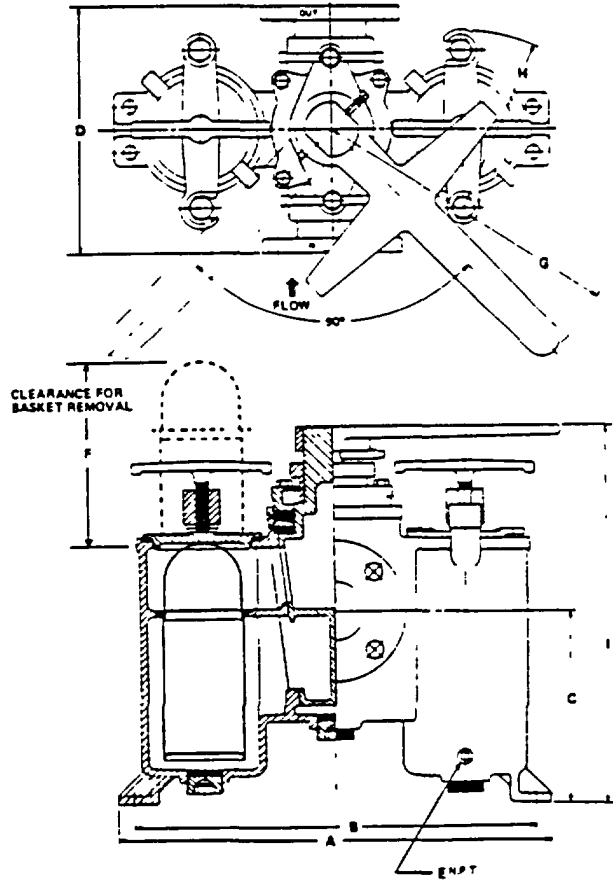
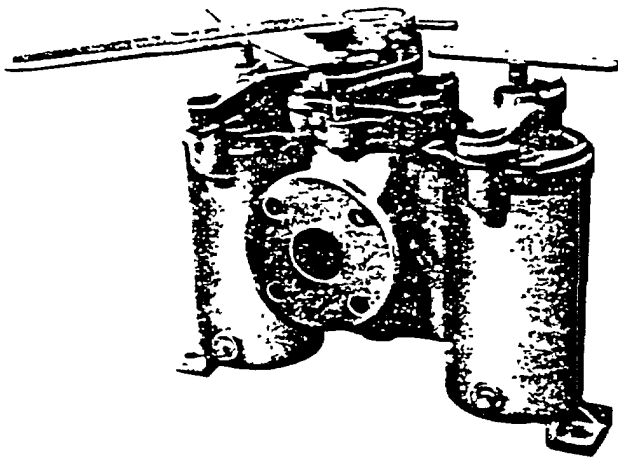

Flanges are to 150 lb. ANSI dimensions.

Pipe Size	Net Weight (lbs.)				A	B	C	D	E	F	G	H	I
	Iron	Bronze	Stainless	Carbon Steel									
2	111	114	120	120	18 ³ / ₈	17 ³ / ₈	8 ³ / ₈	10 ³ / ₈	3 ¹ / ₈	10 ¹ / ₂	13 ¹ / ₂	7 ⁵ / ₈	16 ³ / ₈
2½	118	119	138	135	18 ³ / ₈	17 ³ / ₈	8 ³ / ₈	10 ³ / ₈	3 ¹ / ₈	10 ¹ / ₂	13 ¹ / ₂	7 ⁵ / ₈	16 ³ / ₈
3	177	220	198	204	22	20 ³ / ₈	8 ⁷ / ₈	13 ¹ / ₂	3 ¹ / ₈	13 ¹ / ₈	16 ¹ / ₄	9	17 ⁷ / ₈

FLANGED

Dimensions are in inches

These dimensions are for reference only. For installation purposes, request certified drawings.

Hayward®

Model

Dimensions

Flanged

Pipe Sizes: 2" - 2½" - 3"

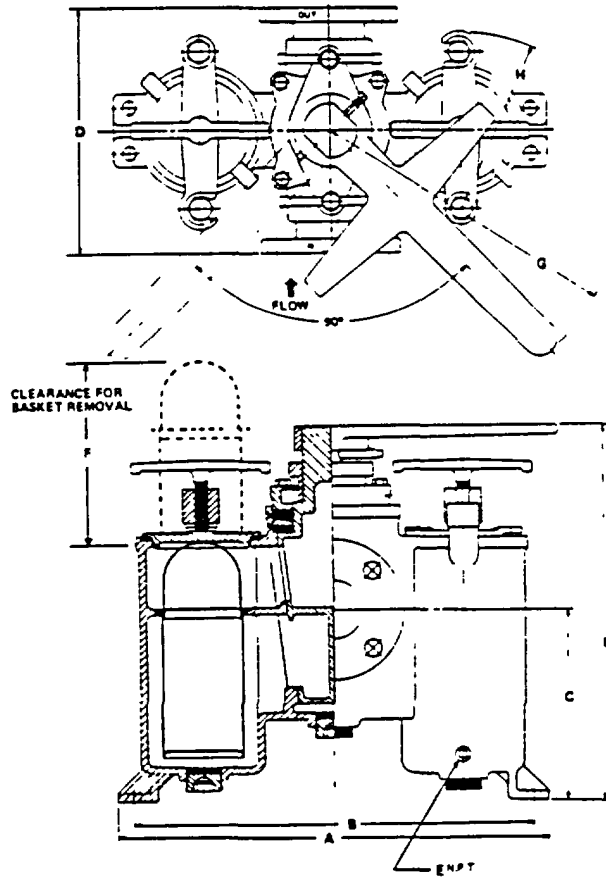
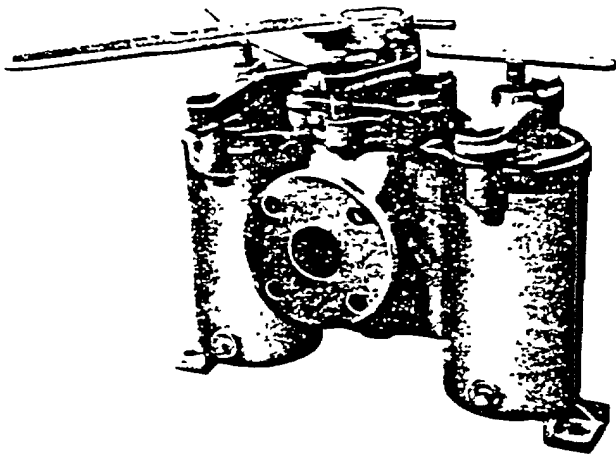

Flanges are to 150 lb. ANSI dimensions.

Net Weight (lbs.)

Pipe Size	Net Weight (lbs.)				A	B	C	D	E	F	G	H	I
	Iron	Bronze	Stainless	Carbon Steel									
2	111	114	120	120	18 ³ / ₈	17 ³ / ₈	8 ³ / ₈	10 ³ / ₈	3 ¹ / ₈	10 ¹ / ₂	13 ¹ / ₂	7 ⁵ / ₈	16 ³ / ₈
2½	118	119	138	135	18 ³ / ₈	17 ³ / ₈	8 ³ / ₈	10 ³ / ₈	3 ¹ / ₈	10 ¹ / ₂	13 ¹ / ₂	7 ⁵ / ₈	16 ³ / ₈
3	177	220	198	204	22	20 ³ / ₈	8 ⁷ / ₈	13 ¹ / ₂	3 ¹ / ₈	13 ¹ / ₈	16 ¹ / ₄	9	17 ¹ / ₄

FLANGED

Dimensions are in inches

These dimensions are for reference only. For installation purposes, request certified drawings.

Hayward®

Model

Flanged with lifting jack handwheel

Pipe Size: 4"

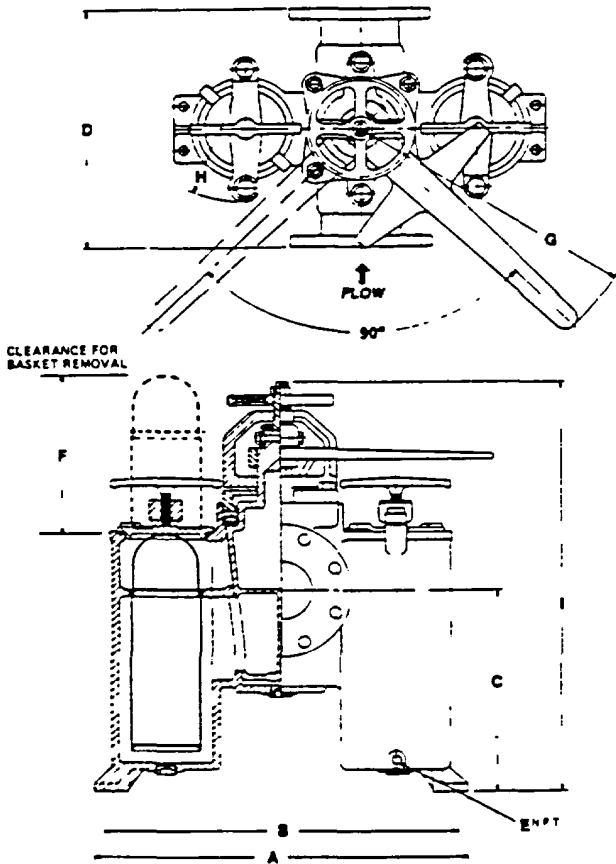

Flanged with lifting jack handwheel

Pipe Sizes: 5" - 6" - 8"

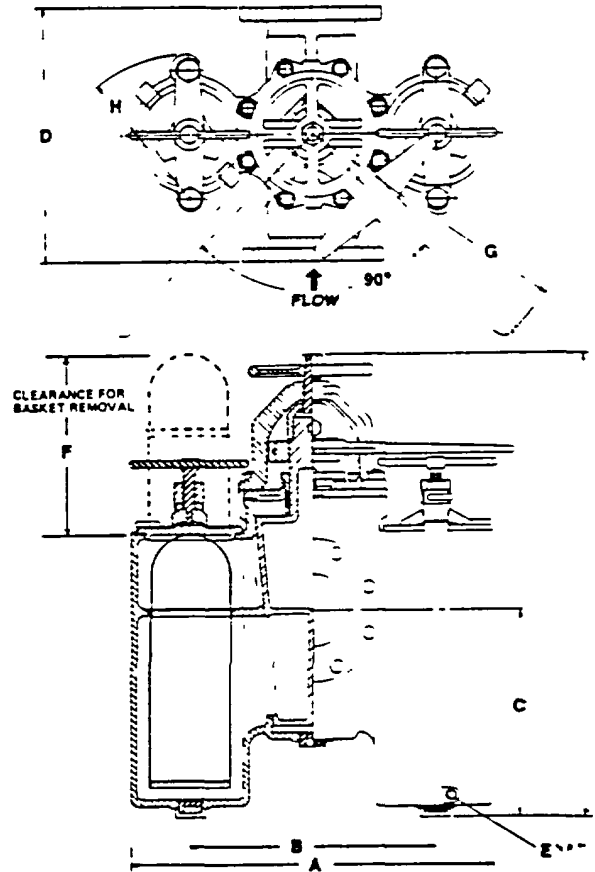

Flanges are to 150 lb ANSI dimensions

	Net Weight (lbs)				A	B	C	D	E	F	G	H	I	
	Pipe Size	Iron	Bronze	Stainless Steel										
FLANGED	4	260	283	282	300	23	21½	13¼	16	¾	15¾	19¼	9	30
	5	403	412	—	—	26	17¼	14¾	18¾	¾	19¼	19¾	10¼	33¼
	6	500	—	—	—	32	20¾	19½	22	¾	19¾	19¾	11¾	34¼
	6	—	583	—	—	32	21¼	15½	21½	¾	19¾	19¾	11¾	34¼
	6	—	—	615	—	31¼	20¾	18½	22	¾	19¾	19¾	11¾	35
	6	—	—	—	580	31¼	20¾	18½	22	¾	19¾	19¾	11¾	35
	8	1500	1800	1670	1610	45½	30¾	23	25	½	26¾	28½	—	50¾

Dimensions are in inches

These dimensions are for reference only. For installation purposes, request certified drawings



INSTRUCTION MANUAL

REPAIR

MODEL 321 (GAHA)

6

SERVICE

Your Aurora pump requires no maintenance other than periodic inspection and occasional cleaning. The intent of inspection is to prevent breakdown, thus obtaining optimum service life. The pump is lubricated by the liquid being pumped and therefore does not require periodic lubrication. The motor, however may require lubrication, in which case, the motor manufacturer's recommendation should be followed.

REPAIRS

The pump may be disassembled using the illustrations and text provided. Although complete disassembly is covered, it will seldom be necessary to completely disassemble your Aurora pump.

The illustrations accompanying the disassembly instructions show the pump at various stages of disassembly. The illustrations are intended to aid in the correct identification of the parts mentioned in the text.

Inspect removed parts at disassembly to determine their reusability. Cracked castings should never be reused. All packing and gaskets should be replaced with new ones at reassembly simply as a matter of economy; they are much less expensive to replace routinely than to replace as the need occurs. In general it is economical to return to the manufacturer for repair only the motor and motor controller.

Disassembly of the Pump. Disassemble only what is needed to make repairs or accomplish inspection.

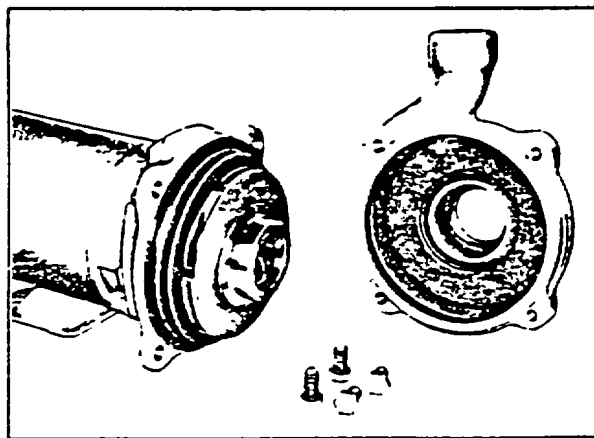

A Pump casing removed.

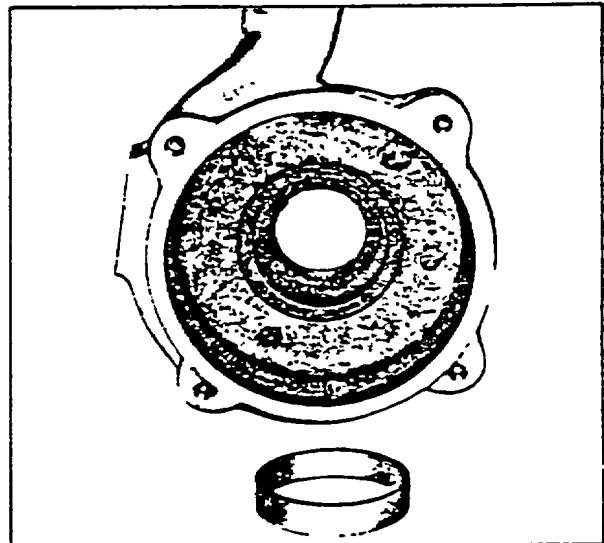

B Wearing ring removed from casing

Proceed to disassemble the pump as follows: (See Figure 2.)

1. Remove the four nuts (1) or screws (2) and separate the pump casing (4), from seal bracket (18). Tap the casing with a soft hammer to loosen it.
2. Unscrew the plugs (3) from the casing (4).
3. Use a puller to extract the wearing ring (5) from pump casing.

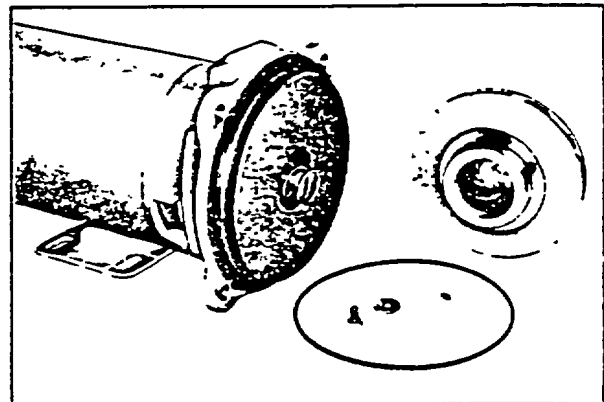

C Impeller with retaining screw, washer, key, and "O" ring Note seal spring in seal bracket.

NOTE

The wearing ring (5) is pressed into the casing with a press fit. It is likely that during removal this fit will be lost. For this reason the wearing ring should never be removed from the casing unless it is to be replaced.

4. Remove studs (6) if pump is so equipped.

5. Remove screw (7) and washer (8) securing impeller (9) to the motor shaft.

6. Remove impeller (9) and key (10) from the motor shaft.

NOTE

A puller may be used to remove the impeller or it may be pried loose. Care should be taken that the impeller is not damaged during removal.

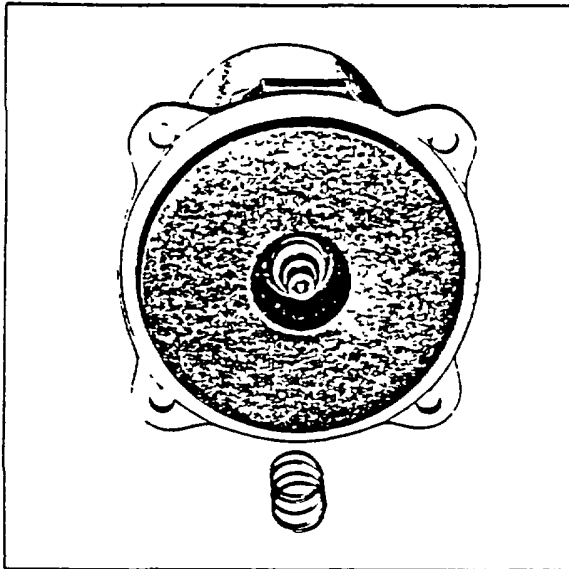

D Seal spring removed with remaining seal parts still on shaft.

7. Pry out "O" ring (12) only if it is damaged.

8. Remove the pipe plug (13) from the seal bracket.

9. Remove screws (16) and washers (17) if so equipped and carefully slide the seal bracket (18) and mechanical seal (11) off the motor shaft.

NOTE

The seal spring can be removed prior to the removal of the seal bracket.

10. Carefully push the seal seat and cup out of the seal bracket.

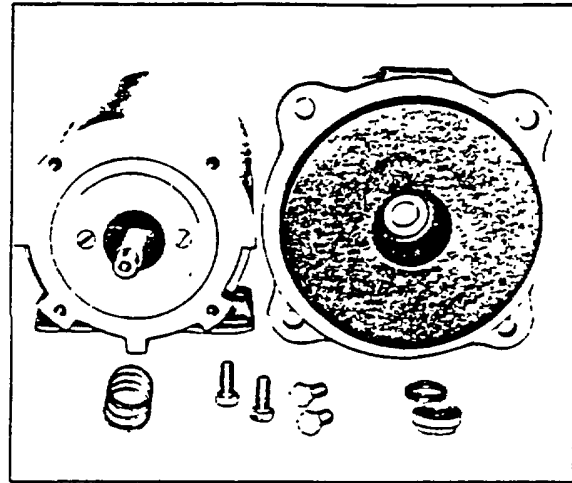

E. Seal bracket removed with seal drive ring, retainer, and flexible bellows assembled and seal washer loose. Note seal cup and seat still in bracket.

CAUTION

The mechanical seal (see Figure 1) is a precision product and must be treated as such. During removal great care must be taken to avoid dropping any part of the seal. Take particular care not to scratch the lapped faces on the washer on the sealing seat. Do not put a seal back into service until the sealing faces of the washer and seat have been lapped or the washer and seat have been replaced.

12. Remove the pump nameplate (15) and screws (14) only if replacement is necessary.

13. Remove rubber slinger (19) from motor shaft.

INSPECTION

When the pump is disassembled, the parts should be cleaned and inspected for damage. Specifically inspect:

1. The seal faces for chips, scratches and other damage that may have occurred during removal. The seal faces are lapped surfaces and must be relapped or the washer and seat replaced before reassembly.

2. The seal cavity in the seal bracket for burrs or nicks that could damage the flexible cup of the seal.

3. The impeller hub and casing wearing ring for signs of excessive wear.

4. The "O" ring for abrasions, cuts or other damage.

Also inspect all castings for cracks or other damage that could impair pump operation.

MODEL 321

REASSEMBLY

Reassembly of the pump will generally be in reverse order of disassembly, but not exactly so. If disassembly was not complete use only those steps related to your particular repair program.

1. Position the pump bracket (18) on the motor and secure with washers (17) and screws (16). Tighten screws evenly.

2. Install plug (13) to the seal bracket. Position "O" ring (12) on the seal bracket and gradually slip into its groove.

NOTE

The mechanical seal (11) (see Figure 1) cannot be installed as an assembly. It is necessary to have the seal seat properly in place before the balance of parts can be added.

3. Apply a film of soap paste or light oil (not grease) to the flexible cup and seal seat. Insert the seat in the cup and install in the pump bracket (18). If it is not possible to insert seat with fingers, place cardboard protecting ring, furnished with seal, over lapped face of seat and press into place with a piece of tubing having end cut square. Tubing should be slightly larger than the diameter of the shaft. Remove cardboard ring after seat is firmly seated.

4. Apply a film of soap paste only (not oil or grease) to the washer and bellows of the seal, and slide the remaining seal parts onto the shaft, making sure the washer is seated against the seal seat.

Refer to figure 1 for correct assembly of seal parts.

5. Install key (10) on shaft and assemble impeller (9). Be sure spring of mechanical seal is properly positioned on back side of impeller. Secure impeller with washer (8) and screw (7).

6. Assemble studs (6) if used, into pump casing.

7. Install the wearing ring (5) into the casing (4). The wearing ring must be pressed into pump casing. Do not attempt to hammer it into position. An arbor press would be ideal, however, placing a block of wood over the ring and pressing it in will work satisfactorily.

CAUTION

Because the wearing ring is a press fit it must be given special care. Be sure the ring is positioned squarely over the casing bore. With a soft hammer tap the ring gently so it enters the bore evenly.

8. Install two pipe plugs (3) in the pump casing. Position the pump casing against the seal bracket and secure with screws (2) or nuts (1) as required.

9. Attach the nameplate (15) to the casing with screws (14) if it has been removed.

Starting Pump After Reassembly. Do not start pump until all air and vapor has been bled and making sure that there is liquid in the pump to provide the necessary lubrication. It is possible that the mechanical seal may drip during first few minutes of operation.

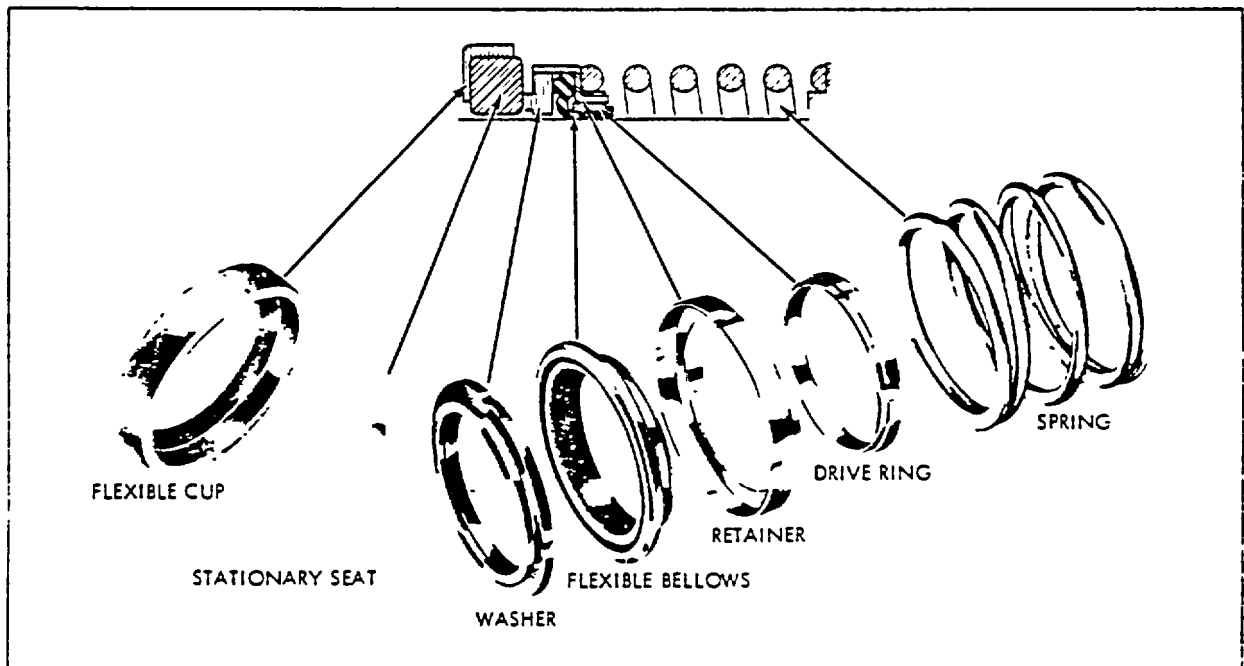
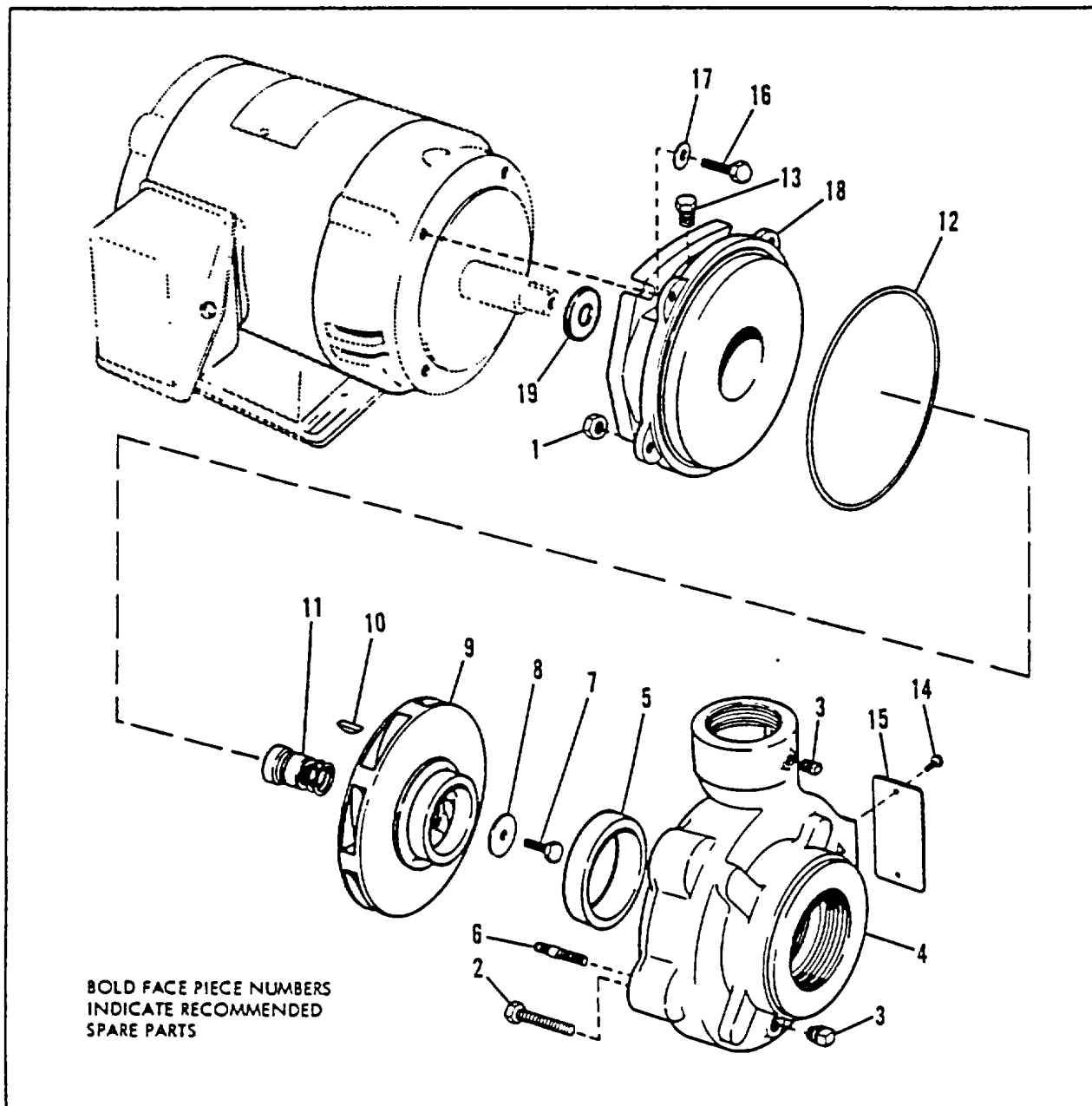

Figure 1. Mechanical Seal

MODEL 321



**BOLD FACE PIECE NUMBERS
INDICATE RECOMMENDED
SPARE PARTS**

- | | | |
|-----------------|---------------|---------------|
| 1. Nut | 8. Washer | 14. Screw |
| 2. Capscrew | 9. Impeller | 15. Nameplate |
| 3. Pipe Plug | 10. Key | 16. Capscrew |
| 4. Casing | 11. Seal | 17. Washer |
| 5. Wearing Ring | 12. Gasket | 18. Bracket |
| 6. Stud | 13. Pipe Plug | 19. Slinger |
| 7. Capscrew | | |

Figure 2. GAHA Pump Exploded View

NOTE

WHEN ORDERING SPARE PARTS ALWAYS INCLUDE THE PUMP TYPE, SIZE, SERIAL NUMBER, AND THE PIECE NUMBER FROM THE EXPLODED VIEW IN THIS MANUAL.

ORDER ALL PARTS FROM YOUR LOCAL AUTHORIZED DISTRIBUTOR, FACTORY BRANCH SALES OFFICE OR THE FACTORY AT AURORA, ILLINOIS

22½° Profile

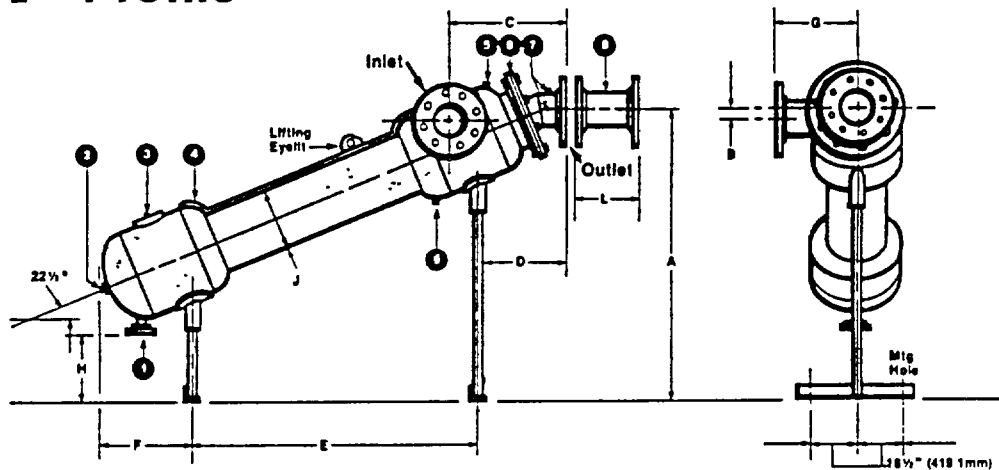

1. Primary purge outlet.
2. Auxillary bleed outlet.
3. Inspection/Cleanout port, 4½"x6" (114.3mm x 152.4mm).
4. Venturi pressure relief line for improved quiescent (calm) solids collection.

5. Air relief port, ¾" N.P.T., female
6. Removable upper dome for internal access.
7. Gauge/flow meter connections, ½" N.P.T., female. One on inlet & two on outlet.

8. Flanged spool (recommended — not included with separator) to allow for removal of upper dome.
9. Inspection plug, 2" N.P.T., female.

90° Vertical Profile

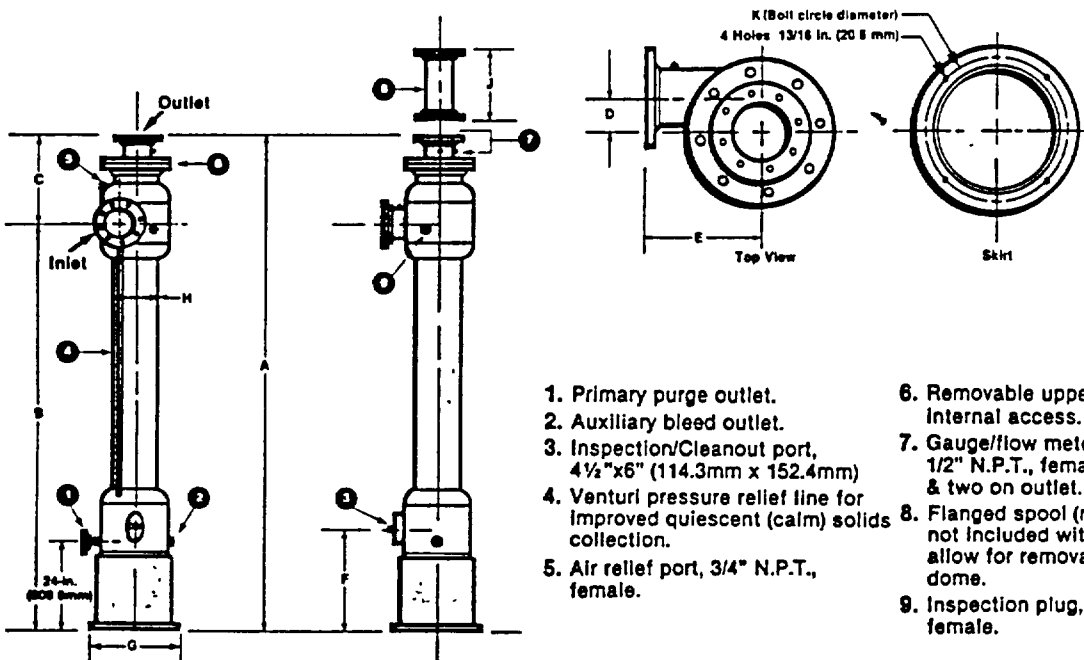

1. Primary purge outlet.
2. Auxillary bleed outlet.
3. Inspection/Cleanout port, 4½"x6" (114.3mm x 152.4mm)
4. Venturi pressure relief line for improved quiescent (calm) solids collection.
5. Air relief port, ¾" N.P.T., female.

6. Removable upper dome for internal access.
7. Gauge/flow meter connections, ½" N.P.T., female. One on inlet & two on outlet.
8. Flanged spool (recommended — not included with separator) to allow for removal of upper dome.
9. Inspection plug, 2" N.P.T., female.

Dimensions

Inches/Millimeters

MODEL	A	B	C	D	E	F	G	H	J	L*
L-4042-FD	65-1/4 1657.4	2-3/4 69.8	17-7/8 454.2	14-13/16 376.2	53 1346.2	10 254.0	11-3/4 298.4	30 762.0	6-5/8 168.4	22 558.8
L-4052-FD	74-7/8 1901.9	3-11/16 93.7	22-7/8 581.2	19-1/8 485.9	63-9/16 1614.4	15-1/4 387.4	14 355.6	30 762.0	8-3/4 222.2	24 609.6
L-4062-FD	75-1/8 1908.3	3-3/4 95.2	23-1/16 585.7	19-1/2 495.3	63-9/16 1614.4	15-1/4 387.4	14 355.6	30 762.0	10-3/4 273.1	24 609.6
L-4082-FD	84-1/2 2146.3	4-1/8 104.9	28-3/4 730.2	23-1/16 585.7	75-15/16 1928.9	21 533.4	15-3/4 400.1	30 762.0	12-3/4 323.8	36 914.4
L-4102-FD	95-1/8 2416.3	5-7/16 138.2	34-1/2 876.3	25-3/4 654.1	83-11/16 2125.7	22 558.8	20 508.0	32 812.8	16 408.4	36 914.4
L-4122-FD	103-7/8 2638.5	6-3/8 162.1	39-3/8 1000.2	30-1/4 768.4	99-5/16 2522.5	28 711.2	21-1/2 546.1	32 812.8	18 457.2	38 965.2

Millimeters shown in shaded bands

*Indicates required length of flanged spool (not included) for removal of L-FD's flanged dome, should internal access ever be necessary.

Dimensions

Inches/Millimeters

MODEL	A	B	C	D	E	F	G	H	J*	K
L-4049-FD	99-1/8 2517.9	82-15/16 2108.7	16-1/8 409.7	2-3/4 69.8	11-3/4 298.4	25-2/5 645.2	16 406.4	6-5/8 168.4	26 660.4	13 330.2
L-4059-FD	116-7/8 2968.7	96-1/4 2444.7	19-11/16 500.1	3-11/16 93.7	14 355.6	26-2/5 670.6	20 508.0	8-3/4 222.2	28 711.2	17 431.8
L-4069-FD	116-15/16 2970.3	97-3/8 2473.4	19-11/16 500.1	3-11/16 93.7	14 355.6	26-2/5 670.6	20 508.0	10-3/4 273.0	28 711.2	17 431.8
L-4089-FD	138-3/16 3510.0	112-3/4 2863.8	25-7/16 646.2	4-1/16 103.1	15-3/4 400.0	27-5/8 701.8	26 660.4	12-3/4 323.8	34 863.6	22 558.8
L-4109-FD	154-1/8 3914.9	123 3124.2	31-1/8 790.7	5-5/8 143.0	20 508.0	29 736.6	30 762.0	16 406.4	38 965.2	26 660.4
L-4129-FD	178-1/2 4533.9	143-7/8 3654.6	34-5/8 879.6	6-3/8 162.0	21-1/2 546.1	30-1/2 774.7	32 812.8	18 457.2	42 1066.8	28 711.2

Millimeters shown in shaded bands

*Indicates required length of flanged spool (not included) for removal of L-FD's flanged dome, should internal access ever be necessary.

L-FD Industrial Service Separators



Practical solids-removing filtration equipment for high flow rate applications.

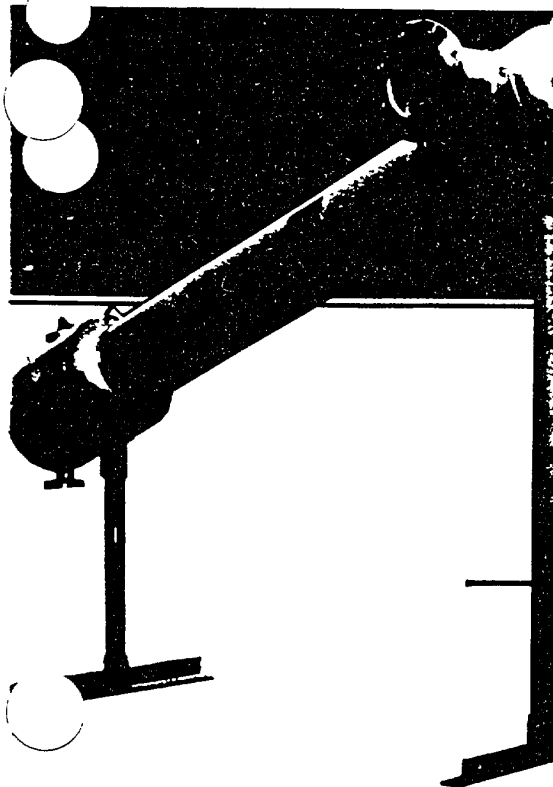

Featuring the patented Lakos method of centrifugal-style filtration, the L-FD Separator offers an effective solution for solids removal in virtually any liquid system. Like all Lakos Separators, the L-FD Series has no moving parts to wear out, no screens, cones, cartridges or filter elements to

clean or replace, requires no backflushing or media replacement and operates within a pressure loss range of 4.5-12 psi (.3-.8 kg/cm²). Other than purging (a simple task easily automated), Lakos L-FD Separators require no routine maintenance and need never be shutdown for routine servicing. Compact in size and simple in operation (see inside pages), its easy installation and sure performance highlight many valuable features.

- **Small, large & fibrous solids removal** — Unique internal construction helps the L-FD Series to effectively remove a broad range of solids and heavy concentrations without plugging or loss of efficiency.

Often, no pre-filters or polishing filters are even necessary. The solids removal capabilities of this series, especially when the application involves heavy industrial/process solids, consistently exceeds the typical Lakos sand-from-water rating of 98% of all particles 200 mesh (74 microns) and larger. See page 3 regarding maximum separable particle sizes.

- **Easy internal access** — When an application threatens troublesome solids or conditions, the L-FD's flanged, removable upper dome and a convenient inspection/clean-out port at the collection chamber offer direct accessibility to the separator's chambers for either inspection or removal of unusual solids.
- **Auxiliary bleed/purge outlet** — This series has been designed with deluxe purging accommodations for maximum control of solids evacuation. Actual purge outlets have been sized per unit so that every model can be fully purged within 15 seconds. Standard elevations have also been pre-

determined to allow for proper installation of purge hardware (see diagram, page 2). A secondary purge outlet is also provided for use either as a stand-by (should the primary purge system require servicing) or as a supplemental bleed line to help evacuate especially heavy purged solids loads. See Maintenance/Purging, page 2.

- **Pressure relief line for effective solids collection** — This patented feature encourages the quiescent (calm) accumulation of separated solids in the Lakos Separator's lower chamber, thereby maximizing its temporary storage capacity and effective purge characteristics.
- **Two profiles accommodate space limitations** — Standard 22½° low profile typically minimizes the need to elevate installation piping and keeps all components at a serviceable level. Optional 90° vertical profile requires little floor space and fits well into many existing piping schemes. See page 3 for specific details.
- **Optional coatings & material construction** — Standard carbon steel may be coated or replaced with other metals to improve resistance to chemicals, caustics and other abrasive liquids/solids. Typical coatings: Scotchkote® and Kynar®. Consult your Lakos representative for details.

Flow Range:

220-3,300 U.S. gpm
(50.0-749.4m³/hr)

Maximum Pressure Rating:
125 psi (8.8 kg/cm²)

This series consists of six models. For higher flow rates, refer to Lakos R-FD Series Separators.

Ask your Lakos representative about the many other Lakos Separators and equipment available for a wide variety of solids from liquids applications.

Contents

Product Description
Operation

Installation Instructions
Maintenance/Purging

Engineering Data
Sample Specifications

I. Operation

Lakos L-FD Separators are designed specifically to remove solids from liquids. Each model is designed for use within a prescribed flow range for maximum performance and solids removal. Flow rates above or below the recommended range (see page 5)

may affect such performance.

Upon tangential entry, the liquid/solids are accelerated by Lakos' Annular Transfer Ring into the separation chamber, where solids heavier than the carrying liquid are centrifugally separated and allowed to

accumulate in the unit's collection chamber for eventual purging (see Section III). The liquid (free of separable solids) is then drawn to the vortex and up through the separator's outlet.

II. Installation Instructions

1. Lakos L-FD Separators are shipped on a wooden skid with their two support legs detached (22½° profile only). A large ring, located on the unit's side (22½° profile only), is provided for hoisting as necessary.

2. A suitable foundation is necessary to accommodate the Lakos Separator's weight *including liquid* (see data, page 5). Tie-down bolts are recommended in the base of the legs (22½° profile) or skirt (90° profile).

3. Prior to installation, the inlet, outlet and purge of each unit should be inspected for the presence of any foreign objects which may have entered the unit during shipping or storage.

4. Other than attaching the support legs, no other preparations are necessary prior to installation. Purge hardware, however, is required before start-up (See Section III).

5. Pipe connections to the inlet and outlet of Lakos L-FD Separators should be a straight run of at least five pipe diameters to minimize turbulence. A flanged spool of appropriate length (see diagrams, page 3) is necessary at the L-FD Separator's outlet to allow for removal of the upper dome should inspection/clean-out ever be necessary.

6. All Lakos Separators operate within a prescribed flow range (see data, page 5). **Pipe size is not a factor in model selection.** Use appropriate hardware to match inlet and outlet flange sizes. Flange bolts and gaskets are not included with separator.

7. Minimum inlet pressure should be at least 15 psi (1.0 kg/cm²) or equal to the pressure loss anticipated through the separator (see graph, page 5) *plus* the system's down-stream pressure requirements.

8. Lakos L-FD Separators are typically installed on the discharge of a pumping system. Consult your Lakos representative for suction side installation. No other pressure or power is required to operate Lakos L-FD Separators.

9. In a pressurized system (vs. open discharge), pressure gauges are recommended at both inlet and outlet to monitor pressure loss and proper system flow (see flow graph, page 5).

10. Winterizing is important if the Lakos Separator is to remain idle in sub-freezing locations. Unless measures are taken to insulate the separator from such temperatures, unit should be drained of all liquid to avoid bursting due to ice expansion. Note: All Lakos automatic purging hardware provide a manual override to allow for easy draining via the purge opening.

III. Maintenance/Purging

1. *Lakos L-FD Separators must be purged regularly.* Otherwise, the accumulation of separated solids will overflow the separator's collection chamber, substantially affecting performance.

2. Several purging options are available and all may be performed while the Lakos L-FD Separator is in full operation.

a. **Manual:** A full-port, straight-through valve may be installed on the standard purge opening and actuated manually as necessary to purge separated solids.

b. **Automatic:** The use of Lakos L-FD Separators in a given application typically implies the need for heavy or unusual solids removal. **A Lakos Auto-Purge System & Pneumatic Pinch Valve** is therefore recommended. Should compressed air be unavailable, consult your Lakos representative for details on motorized ball valves and other systems.

c. **Continuous Bleed:** With either a manual pinch valve or **Lakos' Auto-Purge System & Pneumatic Pinch Valve**, a controlled rate of

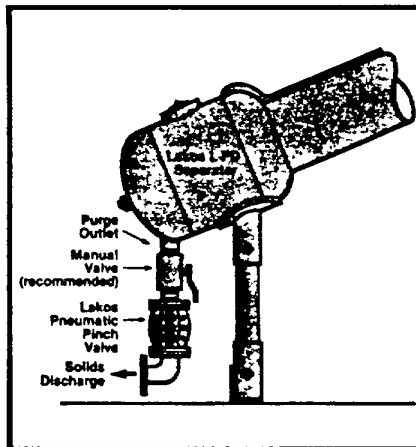

purging is also acceptable and effective. Periodic inspection of a manual valve or programmed full purge of the Lakos Auto-Purge system is recommended to avoid plugging of the reduced bleed orifice.

3. Lakos L-FD Separators feature both a standard purge outlet and a smaller auxiliary bleed outlet. Prior

to start-up, the installation of a manual valve on the auxiliary outlet is recommended so that this outlet may be serviceable at any time for either supplemental purging or as a stand-by, should the primary purge line ever require servicing.

4. Important: All purge hardware should be installed prior to any elbows or turns in the purge piping (see diagram, this page). Avoid "uphill" purging which can clog piping and hinder effective solids evacuation.

5. For best results, actual purging is recommended while the Lakos L-FD Separator is in operation. To determine the necessary frequency, purge often at first and calculate the proper rate with regard to the actual volume of separated solids. Ask your Lakos representative for specific recommendations regarding your application.

6. When operating in sub-freezing temperatures, be sure to protect the L-FD Separator's collection chamber and all purge line piping from freezing. (See Section II, Item 10 regarding winterizing.)

22½° Profile

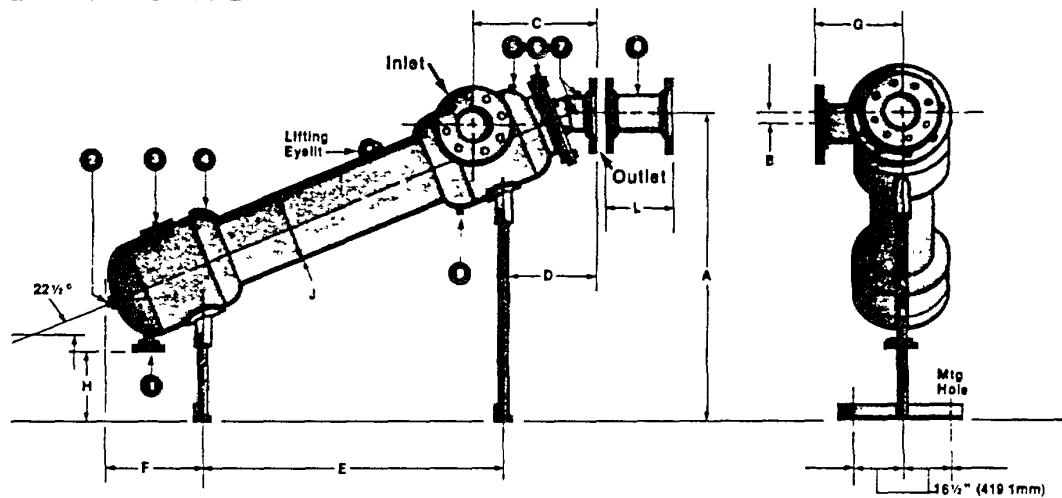

1. Primary purge outlet.
2. Auxiliary bleed outlet.
3. Inspection/Cleanout port, 4½"x6" (114.3mm x 152.4mm).
4. Venturi pressure relief line for improved quiescent (calm) solids collection.
5. Air relief port, 3/4" N.P.T., female.
6. Removable upper dome for internal access.
7. Gauge/flow meter connections, 1/2" N.P.T., female. One on inlet & two on outlet.
8. Flanged spool (recommended — not included with separator) to allow for removal of upper dome.
9. Inspection plug, 2" N.P.T., female.

90° Vertical Profile

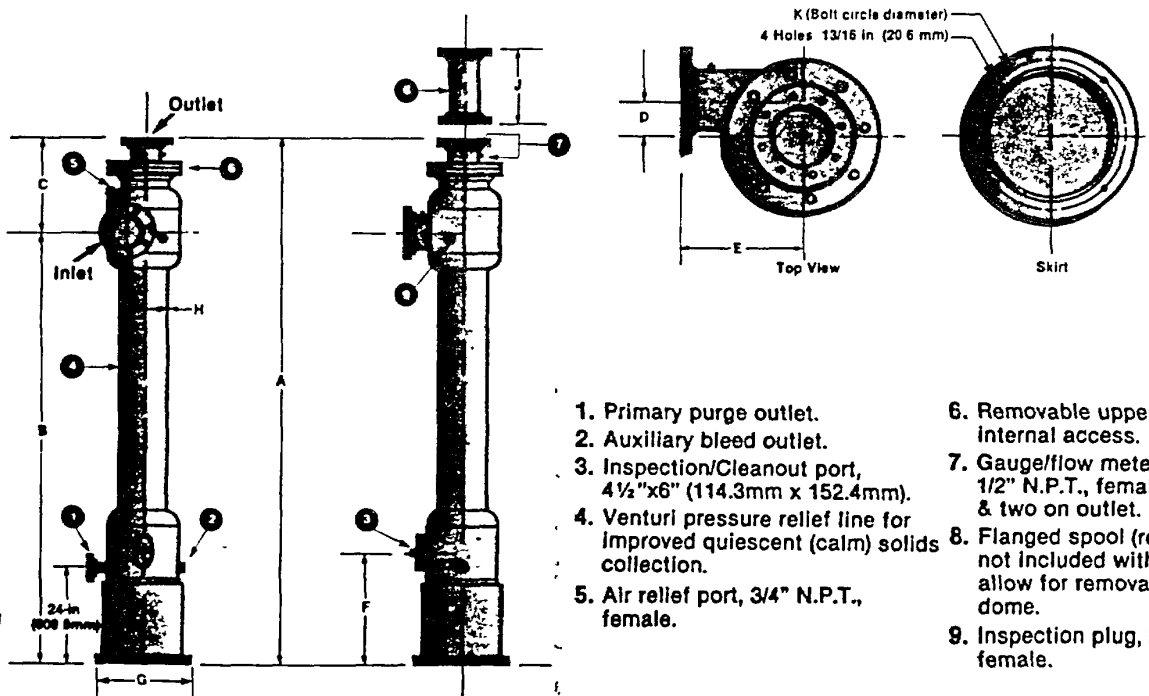

1. Primary purge outlet.
2. Auxiliary bleed outlet.
3. Inspection/Cleanout port, 4½"x6" (114.3mm x 152.4mm).
4. Venturi pressure relief line for improved quiescent (calm) solids collection.
5. Air relief port, 3/4" N.P.T., female.
6. Removable upper dome for internal access.
7. Gauge/flow meter connections, 1/2" N.P.T., female. One on inlet & two on outlet.
8. Flanged spool (recommended — not included with separator) to allow for removal of upper dome.
9. Inspection plug, 2" N.P.T., female.

Sample Specifications

Separator Function:

A centrifugal vortex separator(s) shall be furnished for installation in the liquid supply/circulation system to remove separable* solids from the system. The Separator(s) shall remove 98%, by weight, of separable* solids 200 mesh (74 microns) and larger.

**Separable Solids: Typical performance efficiency criteria applies to moderate viscosity (minus 100 SSU) liquids in the 1.0 specific gravity range and moderate density solids with a specific gravity of 1.8 or greater.*

Separator Design Features:

The separator shall be designed with tangential entry into the acceptance chamber. Upon directed tangential entry, the liquid/solids are accelerated through the internal annular transfer ring into the reduced diameter separation cylinder. The solids heavier than the carrying liquid are centrifugally spiraled down the perimeter of the separation cylinder past the deflector stool and allowed to accumulate in the separator's collection chamber. The liquid (free of separable solids) will follow the vortex created and centered on the deflector stool up through the interior of the separation cylinder and into the vortex finder which becomes the separator outlet.

The separator shall also incorporate a pressure relief line from the collection chamber to the venturi located in the tangential inlet to enhance separation by facilitating quiescent solids sedimentation in the collection chamber. Quiescent solids accumulation shall also be facilitated by the baffle spin arrestor below the deflector stool in the collection chamber. Separation and collection of solids shall not promote excessive wear nor require a continuous "involuntary" underflow

Separator Criteria:

- A. The separator shall have a _____-inch flanged tangential inlet and a _____-inch flanged outlet.
- B. The separator shall have a _____-inch purge outlet a _____-inch auxiliary bleed outlet.
- C. The separator shall operate within a flow range of _____-_____ U.S. gpm with a minimum inlet pressure of _____ psi and a corresponding pressure loss range of _____-_____ psi.
- D. The separator shall be designed for maximum operating pressure of 125 psi.

Separator Construction:

- A. The separator shall be fabricated of carbon steel with shell and head material of minimum 3/16-inch thickness. All flanges will be 125 pound, Class D.
- B. The separator shall have a flanged, removable dome to facilitate any potential servicing or inspection of the acceptance chamber or the separation cylinder.
- C. The separator shall have a 4-inch x 6-inch hand-hole clean-out, conveniently located to allow for the potential servicing or inspection of the collection chamber.
- D. Paint coating shall be Mactek M-Line Enamel, F-9056 Laval Blue.

Separator Identification:

The separator(s) shall be Lakos Separator

Model(s) _____
as manufactured and marketed by Claude Laval Corporation of Fresno, California.

Limited Warranty

All products manufactured and marketed by this corporation are warranted to be free of defects in material or workmanship for a period of one year from date of delivery.

If a fault develops, notify us, giving a complete description of the alleged malfunction. Include the model number(s), date of delivery and operating conditions of subject product(s). We will subsequently review this information and, at our option, supply you with either servicing data or shipping instructions and returned goods authorization. Upon prepaid receipt of subject product(s) at the instructed designation, we will then either repair or replace such product(s), at our option and, if determined to be a

warranted defect, we will perform such necessary product repairs or replace such product(s) at our expense.

This limited warranty does not cover any products, damages or injuries resulting from misuse, neglect, normal expected wear, improper installation or operation contrary to factory recommendations. Nor does it cover equipment which has been modified, tampered with or altered without authorization.

No other extended liabilities are stated or implied and this warranty in no event covers incidental or consequential damages, injuries or costs resulting from any such defective product(s).



Lakos Separators are manufactured and sold under one or more of the following U.S. Patents: 3,289,608; 3,512,651, 3,568,837, 3,701,425, 3,947,364; 3,963,073; 4,072,481; 4,120,795; 4,140,638, 4,147,630, 4,148,735; 4,305,825, and corresponding foreign patents, other U.S. and foreign patents pending.

Claude Laval Corporation

Not connected with The DeLaval Separator Company

1911 N. Helm • P.O. Box 6119 • Fresno, California 93703
(209) 255-1601 • Telex: 355-355 Laval/FSO

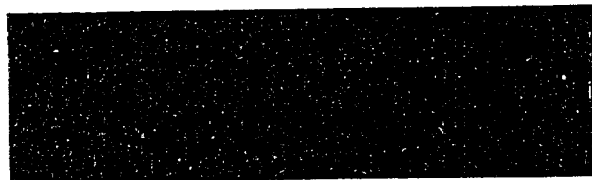

Dimensions

Inches/Millimeters

MODEL	A	B	C	D	E	F	G	H	J	L*
L-4042-FD	65-1/4 1657.4	2-3/4 69.8	17-7/8 454.2	14-13/16 376.2	53 1346.2	10 254.0	11-3/4 298.4	30 762.0	6-5/8 168.4	22 558.8
L-4052-FD	74-7/8 1901.9	3-11/16 93.7	22-7/8 581.2	19-1/8 485.9	63-9/16 1614.4	15-1/4 387.4	14 355.6	30 762.0	8-3/4 222.2	24 609.6
L-4062-FD	75-1/8 1908.3	3-3/4 95.2	23-1/16 585.7	19-1/2 495.3	63-9/16 1614.4	15-1/4 387.4	14 355.6	30 762.0	10-3/4 273.1	24 609.6
L-4082-FD	84-1/2 2146.3	4-1/8 104.9	28-3/4 730.2	23-1/16 585.7	75-15/16 1928.9	21 533.4	15-3/4 400.1	30 762.0	12-3/4 323.8	36 914.4
L-4102-FD	95-1/8 2416.3	5-7/16 138.2	34-1/2 876.3	25-3/4 654.1	83-11/16 2125.7	22 558.8	20 508.0	32 812.8	16 406.4	36 914.4
L-4122-FD	103-7/8 2638.5	6-3/8 162.1	39-3/8 1000.2	30-1/4 768.4	99-5/16 2522.5	28 711.2	21-1/2 546.1	32 812.8	18 457.2	38 965.2

Millimeters shown in shaded bands

*Indicates required length of flanged spool (not included) for removal of L-FD's flanged dome, should internal access ever be necessary.

Dimensions

Inches/Millimeters

MODEL	A	B	C	D	E	F	G	H	J*	K
L-4049-FD	99-1/8 2517.9	82-15/16 2106.7	16-1/8 409.7	2-3/4 69.8	11-3/4 298.4	25-2/5 645.2	16 406.4	6-5/8 168.4	26 660.4	13 330.2
L-4059-FD	116-7/8 2968.7	96-1/4 2444.7	19-11/16 500.1	3-11/16 93.7	14 355.6	26-2/5 670.6	20 508.0	8-3/4 222.2	28 711.2	17 431.8
L-4069-FD	116-15/16 2970.3	97-3/8 2473.4	19-11/16 500.1	3-11/16 93.7	14 355.6	26-2/5 670.6	20 508.0	10-3/4 273.0	28 711.2	17 431.8
L-4089-FD	138-3/16 3510.0	112-3/4 2863.8	25-7/16 646.2	4-1/16 103.1	15-3/4 400.0	27-5/8 701.8	26 660.4	12-3/4 323.8	34 863.6	22 558.8
L-4109-FD	154-1/8 3914.9	123 3124.2	31-1/8 790.7	5-5/8 143.0	20 508.0	29 736.6	30 762.0	16 406.4	38 965.2	26 660.4
L-4129-FD	178-1/2 4533.9	143-7/8 3654.6	34-5/8 879.6	6-3/8 162.0	21-1/2 546.1	30-1/2 774.7	32 812.8	18 457.2	42 1066.8	28 711.2

Millimeters shown in shaded bands

*Indicates required length of flanged spool (not included) for removal of L-FD's flanged dome, should internal access ever be necessary.

Flow vs. Pressure Loss Chart

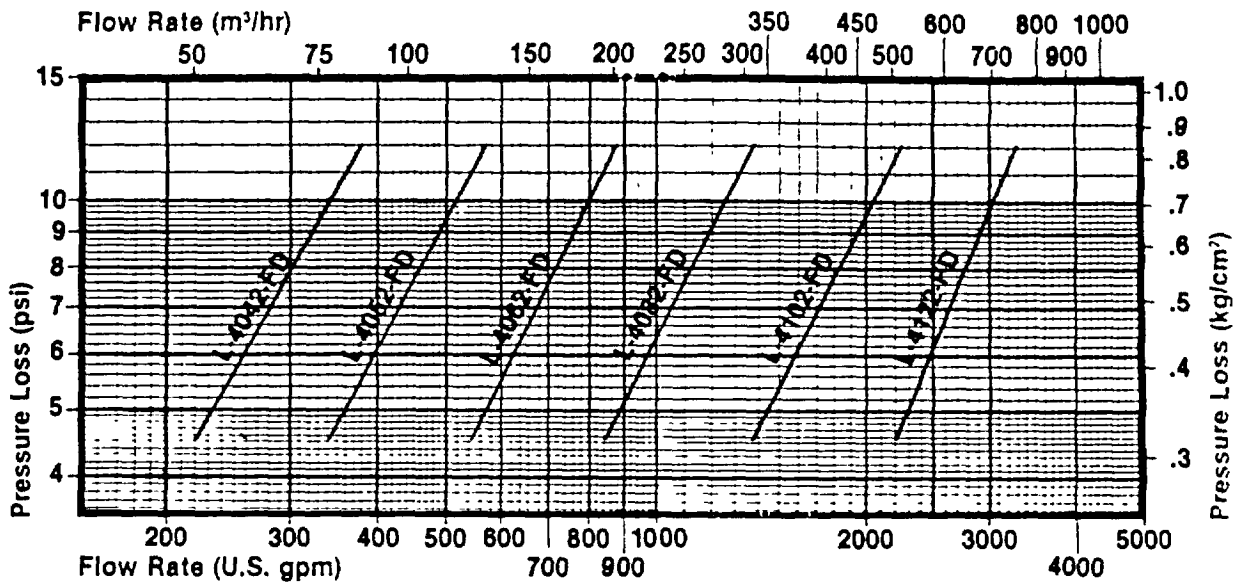

General Specifications

MODEL	FLOW RANGE		INLET/OUTLET Flanged	MAXIMUM PARTICLE		COLLECTION CHAMBER CAPACITY		PURGE SIZES		WEIGHT		WEIGH WITH WA.	
	U.S. gpm	m³/hr		in.	mm	U.S. Gal.	Liters	Standard*	Auxiliary**	lbs	kg	lbs.	kg.
L-4042-FD	220-380	50- 86	4-inch	.4	9.5	3.5	13.2	1-1/2	3/4	325	147	460	209
L-4049-FD						5.6	21.1			308	140	443	201
L-4052-FD	340-570	77-129	6-inch	4	9.5	8.0	30.3	2	1	515	234	805	365
L-4059-FD						12.8	48.5			500	227	790	358
L-4062-FD	540-870	123-198	6-inch	5	12.7	8.0	30.3	2	1	580	263	870	395
L-4069-FD						12.8	48.5			565	256	855	388
L-4082-FD	840-1,390	191-316	8-inch	8	20.6	17.0	64.3	2	1	800	363	1360	617
L-4089-FD						27.2	102.9			775	351	1335	606
L-4102-FD	1,360-2,250	309-511	10-inch	10	25.4	35.0	132.5	3	1-1/2	1275	578	2240	1016
L-4109-FD						56.0	212.0			1235	560	2200	998
L-4122-FD	2,200-3,300	500-749	12-inch	11	28.6	45.0	170.3	3	1-1/2	1860	844	3165	1436
L-4129-FD						72.0	272.5			1795	814	3100	1406

*Standard purge outlet is a screw-on flange (inches)

**Auxiliary purge outlet is N.P.T., female threads (inches)

Maximum Pressure Rating: 125 psi (8.8 kg/cm²)

Pressure Loss Range: 4.5-12 psi (.3-.8 kg/cm²)

Flange Connections: 125 lb., Class D, AWWA, C207.

Material (Standard Carbon Steel): DOMES — S.E. 285C Material, .19-inch (4.83mm) minimum thickness.

OTHER PARTS — SA-36, SA-53B, A-120 or other quality grade, minimum .25-inch (6.4 mm) thickness.

Paint Coating: Mactek M-Line Enamel, F-9056 "Laval Blue".

The information, specifications and performance data stated in this literature are representative of engineering and production standards at the time of publication. Despite quality control, slight variations due to manufacturing, product design improvements and/or sample selection may occur. Actual data may also be revised without notice and you are encouraged to verify pertinent data with the manufacturer when appropriate.



Tank Air Escape Valves

Model 1600



Description: Model 1600 Wager Tank Air Escapes consist of a body (of any material) equipped with a 30 x 30 mesh monel flame screen and a 1/4 x 1/4 mesh monel protecting screen, separated by a spacer ring. These parts are held in place on the body by means of a monel cap and #316 stainless steel screws.

Connections are either screwed IPS, flanged ASA or weld type as required.

Although somewhat similar in design to the Wager Inverted Vent Check Valves, these Tank Air Escapes are *not* equipped with a ball float.

Function: Wager Tank Air Escapes serve to allow the free passage of air into tanks, dry cargo holds, or storage spaces . . . and prevent vacuum or pressure build-up during pumping operations. Since these valves have no float for automatic closing, they should be placed in locations which are not accessible to sea water. The fine monel flame screen protects tank fluids or dry

cargo dust from igniting in the event of deck fires and prevents the entrance of insects into areas serviced by these valves.

A coarse monel Protecting Screen, separated from the Flame Screen by a spacer ring, prevents any mechanical damage to the Flame Screen and acts as a deterrent to clogging this inner screen with paint.

Features:

- 1— OPEN AREA RATIO: Meets latest requirements for ABS, USMA, USCG and U. S. Navy.
- 2— ACCESSIBILITY OF PARTS: Removal of the cap screws facilitates cleaning, inspection and/or replacement.
- 3— RESISTANCE TO CORROSION: Monel and Stainless Steel are used for trim insuring long life.
- 4— BODY MATERIAL: Steel, Stainless Steel, Cast Iron or Bronze.

Exploded View

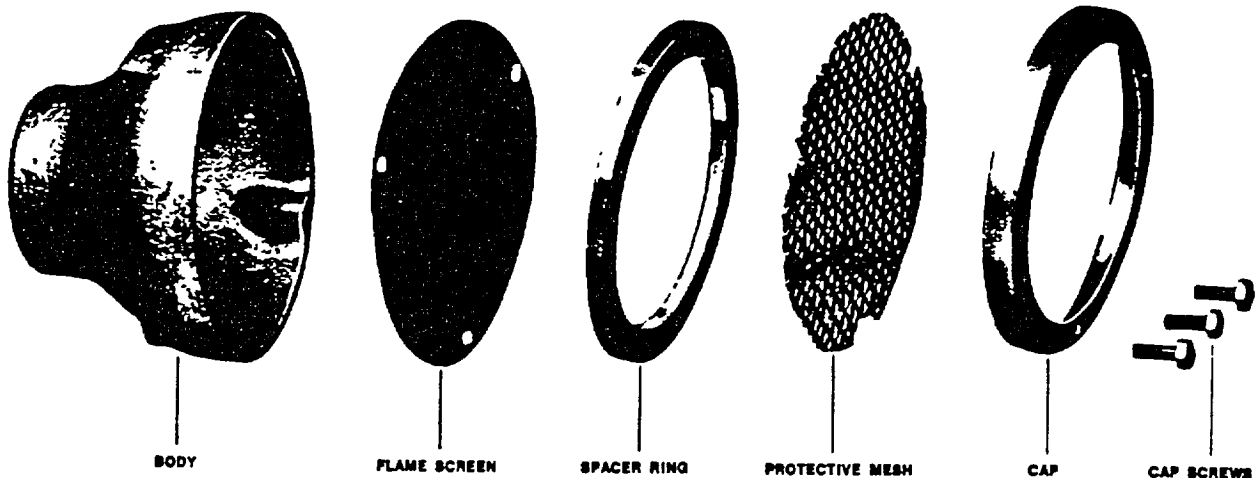

Robert H. Wager Co., Inc.—Passaic Ave., Chatham, N. J. 07928 • Tel. 201-635-9200

Tank Air Escape Valves

Weld Type 1600-W

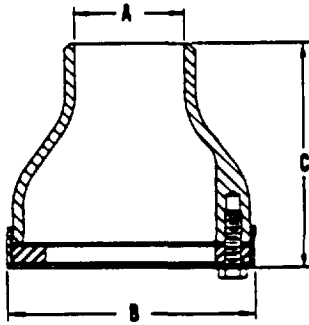

A	1-1/2	2	2-1/2	3	3-1/2	4	5	6	8	10	12
B	3-5/8	4-1/2	5-3/8	6-1/4	-	7-1/4	10-1/4	11-1/2	14-1/2	17-1/8	23-3/4
C	3-11/32	3-11/32	3-27/32	3-27/32	-	4-11/32	7-3/4	8-3/4	9-3/4	12-3/4	16-1/8
WL	2-1/2	3-1/4	4-1/4	5	-	6-1/2	26-1/2	36	52	86	196

Flanged Type 1600-F

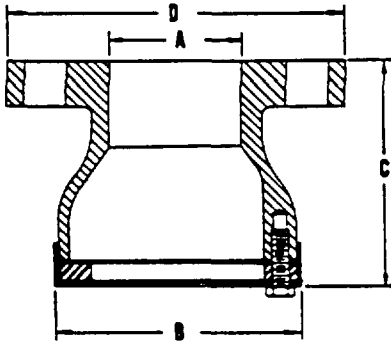

A	1-1/2	2	2-1/2	3	3-1/2	4	5	6	8	10	12
B	3-5/8	4-1/2	5-3/8	6-1/4	-	7-1/4	10-1/4	11-1/2	14-1/2	17-1/8	23-3/4
C	3-11/32	3-11/32	3-27/32	3-27/32	-	4-11/32	7-3/4	8-3/4	9-3/4	12-3/4	16-1/8
D	5	6	7	7-1/2	-	9	10	11	13-1/2	16	19
WL	6-1/2	8-1/4	10	12	-	16-1/2	41	52	87	129	260

Threaded Type 1600-T

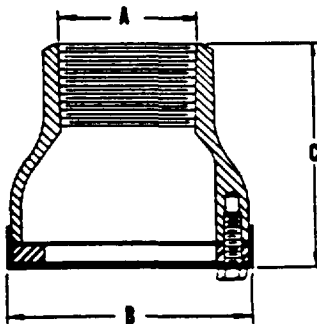

A	1-1/2	2	2-1/2	3	3-1/2	4	5	6	8	10	12
B	3-5/8	4-1/2	5-3/8	6-1/4	-	7-1/4	10-1/4	11-1/2	14-1/2	17-1/8	23-3/4
C	3-11/32	3-11/32	3-27/32	3-27/32	-	4-11/32	7-3/4	8-3/4	9-3/4	12-3/4	16-1/8
WL	2-1/2	3-1/4	4-1/4	5	-	6-1/2	26-1/2	36	52	86	196

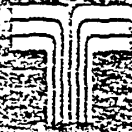

**Transamerica
Delaval**

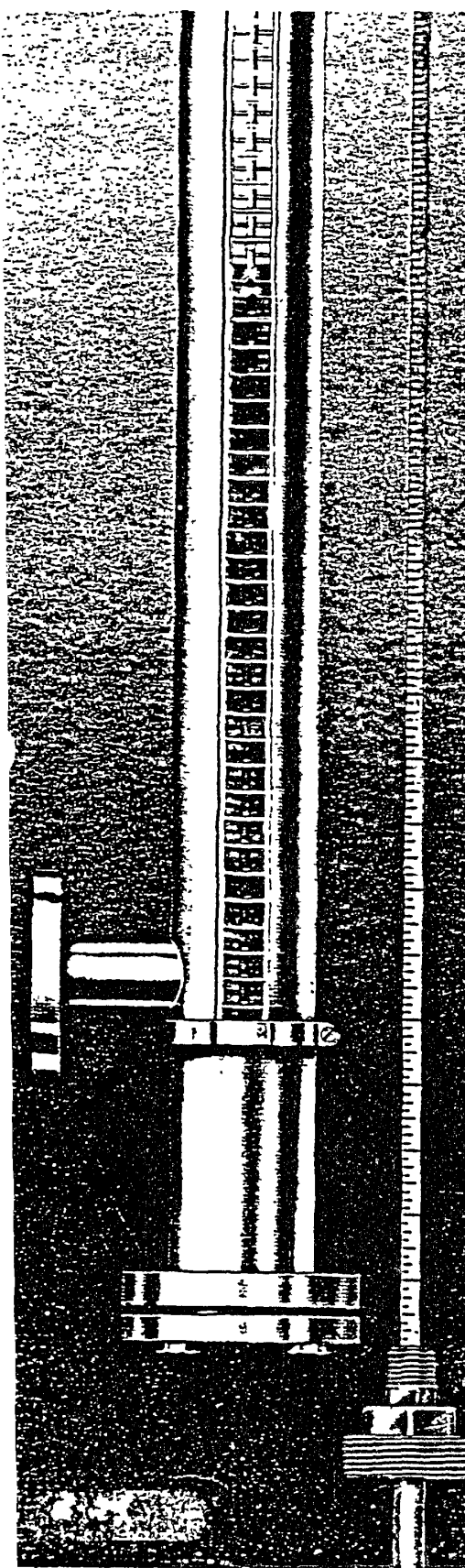

GEMS[®]

LIQUID LEVEL INDICATORS

Copyright 1984, Transamerica Delaval Inc., Gems Sensors Division

Innovative GEMS® designs provide practical solutions.

**GEMS® SureSite®
Visual Level
Indicators...**

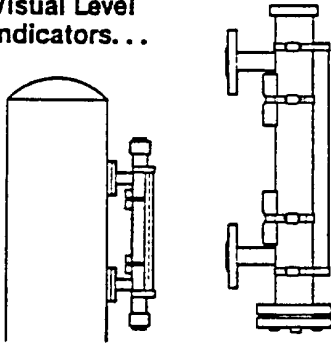

Externally mounted unit provides continuous visual readout of liquid level in the tank ... and automatically, electrically controls pumping equipment or high- and low-level alarms. Easily read visual indicator is non-electrical. Electrical indicator and high- and low-level switches are magnetically actuated by a float within the unit.
See Pages 3-5.

**GEMS® FabriSite®
Liquid Level Indicator
Components...**

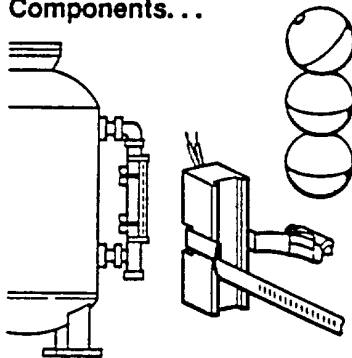

Components offering quick and easy custom assembly of Liquid Level Indicators. Create your own FabriSite custom system with GEMS Flag Assemblies, Float Assemblies, Clamps and Switch Modules using standard casings and fittings available at your local distributor.
See Pages 6-7.

**GEMS® SureSite®/FabriSite®
Liquid Level Indicator
Options...**

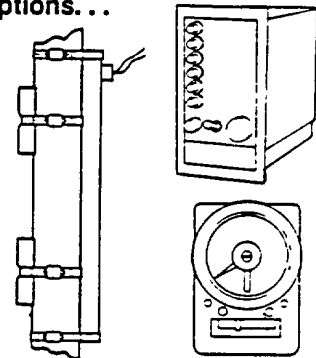

GEMS SureSite/FabriSite accessory options give you the versatility to meet all your specific liquid level indicating needs.
Transmitters ... Standard and High Temperature Switch Modules ... Indicating Scales ... Modular Alarm Panels and Modular Receiver.
See Pages 8-11.

**GEMS® Dipstick
Liquid Level
Indicators...**

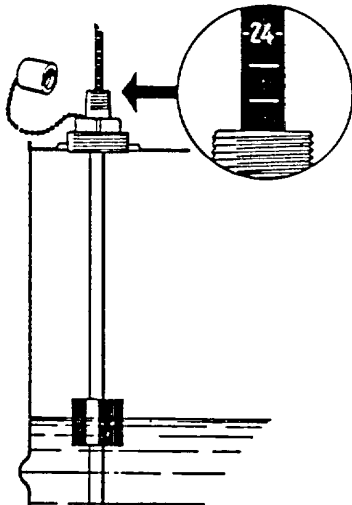

Simple, non-electrical, float-type indicator for storage tanks, drums, vats, etc. Calibrated indicator is manually raised for reading; lowered back out of the way in the unit when not in use.
See Pages 12-13.

**GEMS® Hand-Held
Sounding Tape/Ullage
Indicator...**

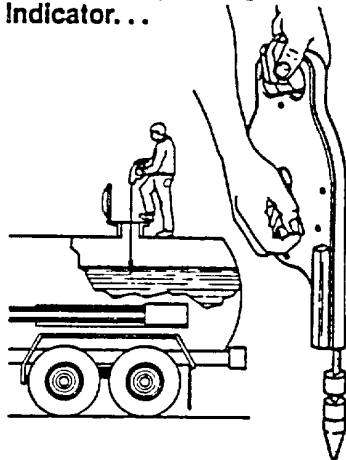

Portable, self-contained unit provides convenient intrinsically safe measurement of ullage in shipboard and barge tanks ... truck tanks and railroad tankers ... underground storage tanks, etc. Easily read, calibrated tape with plumb bob reels in and out of tape gun. Indicator is accurate to 1/8" (3.17 mm).
See Pages 14-15.

Product adaptability to broaden the versatility of our products is an ongoing consideration at Gems. Configurations for specific mounting, electrical connection and installation requirements can be engineered to suit the application, as typically shown here.

Copyright 1984,
Transamerica Delaval Inc.,
Gems Sensors Division

GEMS® LIQUID LEVEL INDICATORS

SureSite®

GEMS SureSite Level Indicators. Safe, easy-to-read, continuous visual indication of liquid levels.

You see it in Gems SureSite, all eight models. Continuous visual indication of liquid level. Rugged construction with virtually maintenance-free design that's adaptable to a variety of tank dimensions. Gems SureSite is ideal whenever level indication, alarm or control applications are required. Ideal for water, oil . . . corrosive, flammable or explosive liquids. Another outstanding product from the famous family of Gems liquid level sensing devices.

Standard Features . . .

- Rugged design . . . easy installation, low maintenance.
- High visibility . . . colored-flag level indicators are easy to read.
- Safety . . . monitored liquid is within float housing.
- Constant indication . . . magnetically interlocked flags are unaffected by shock, vibration or contaminated liquids.
- Stainless steel wetted components are compatible with most liquids.
- Top- or side-mounted models.

Optional Features . . .

- Aluminum flag construction for high temperatures . . . to 500°F (260°C).
- Float configurations and materials for liquid specific gravities down to 0.75.
- Independent SPST switches for control or alarm functions.
- Indicating Scales, 'ROLI' Transmitter, signal conditioners.

Operating Principle . . .

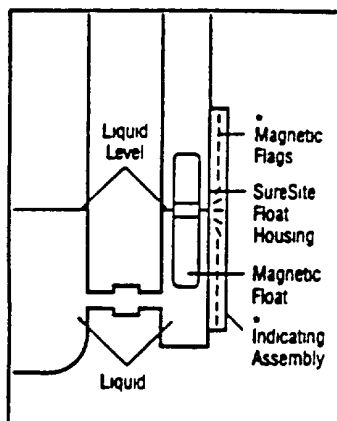

A magnetic float moves up and down with changing liquid levels. An external indicating assembly contains a column of bi-colored flags, each containing a magnet. As the magnetic float moves with the changing liquid level, these interlocking flags provide a highly visible red and white level reading.

*Patent Pending

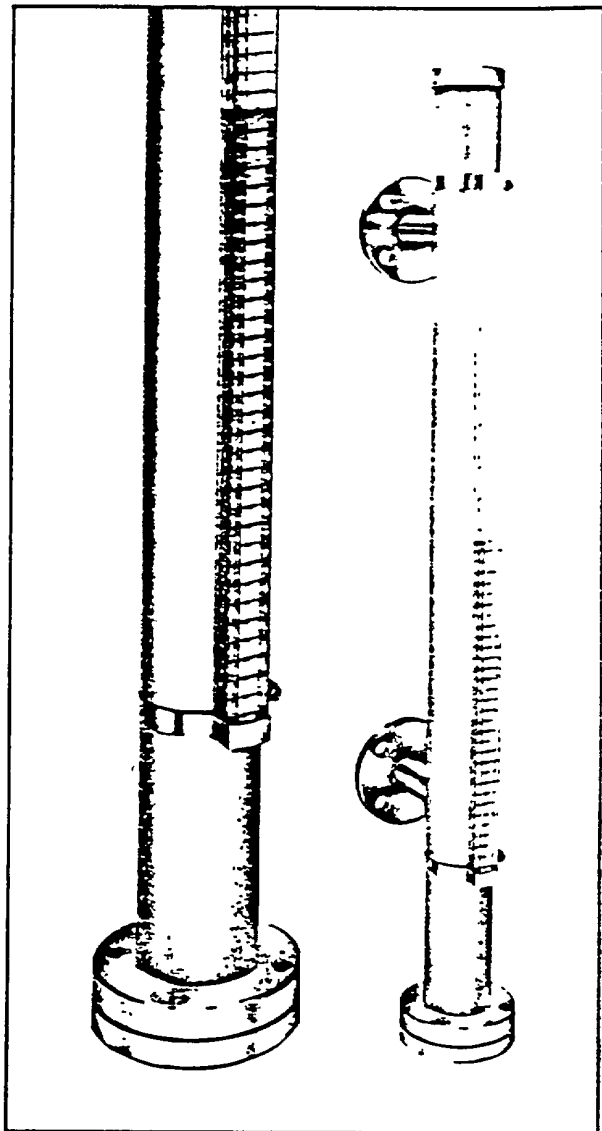

Typical Applications . . .

- Hydraulic reservoirs
- Water treatment
- Refineries
- Chemical and Petrochemical plants
- Beverage processing

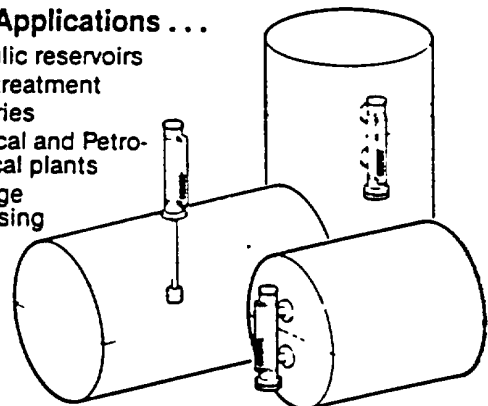

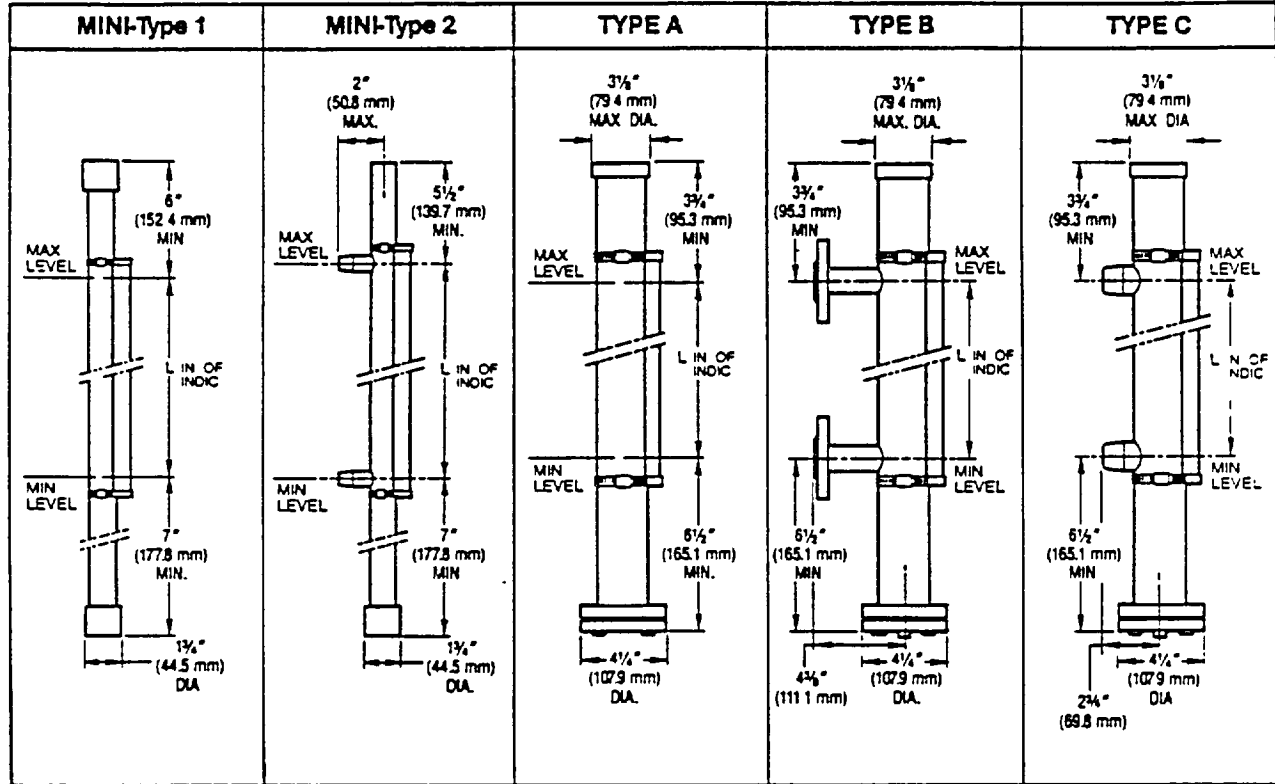
DIMENSIONAL DATA...

SPECIFICATIONS...

	Design Type	Model Number	Housing Material	Float Material	Flag Material	Max. Pressure	Max. Temperature	Connection	Max. Length of Indication	Max. Overall Unit Length
MINI	1	86210	304 SS	304 SS Buna N	P P	150 PSI 150 PSI	300°F (149°C) 180°F* (82°C)	End 1/2" NPT	167" (4241.8mm)	15' (4.57m)
	2		304 SS	304 SS Buna N	P P	150 PSI 150 PSI	300°F (149°C) 180°F* (82°C)	Side, 1/2" NPT	167" (4241.8mm)	15' (4.57m)
STANDARD	A	86500	316 SS	316 SS	P	150 PSI	300°F (149°C)	Top & Bottom 1" NPT (Female)	165" (4191.0mm)	15' (4.57m)
		87055		316 SS	P	600 PSI	300°F (149°C)			
		87110		316 SS	A	600 PSI	500°F (260°C)			
	B	86501	316 SS	316 SS	P	150 PSI	300°F (149°C)	Side, 1"-150# Flange**	165" (4191.0mm)	15' (4.57m)
		87040 87120		316 SS 316 SS	P A	600 PSI 600 PSI	300°F (149°C) 500°F (260°C)	Side, 1"-600# Flange		
	B Inverted ++	86503	316 SS	316 SS	P	150 PSI	300°F (149°C)	Side, 1"-150# Flange**	165" (4191.0mm)	15' (4.57m)
		87140 87125		316 SS 316 SS	P A	600 PSI 600 PSI	300°F (149°C) 500°F (260°C)	Side, 1"-600# Flange		
	C	86502	316 SS	316 SS	P	150 PSI	300°F (149°C)	Side, 1" NPT (Male)	165" (4191.0mm)	15' (4.57m)
87050		316 SS		P	600 PSI	300°F (149°C)				
87130		316 SS		A	600 PSI	500°F (260°C)				
C Inverted ++	86504 87150 87135	316 SS	316 SS 316 SS 316 SS	P P A	150 PSI 600 PSI 600 PSI	300°F (149°C) 300°F (149°C) 500°F (260°C)	Side, 1" NPT (Male)	165" (4191.0mm)	15' (4.57m)	

GEMS® LIQUID LEVEL INDICATORS

SureSite®

DIMENSIONAL DATA...

TYPE D	TYPE E	TYPE F	FLANGES
	<p>SS-3 = 2 1/8" (73.0 mm) MIN DIA SS-5 = 4 1/2" (114.3 mm) MIN DIA CS-3 = 2 1/4" (63.5 mm) MIN DIA</p> <p>B' - SUPPLIED BY CUSTOMER C' - REMAINDER OF FLOAT NOT SUBMERGED D' - FLOAT SUBMERGENCE</p>	<p>B' - SUPPLIED BY CUSTOMER C' - REMAINDER OF FLOAT NOT SUBMERGED D' - FLOAT SUBMERGENCE</p>	<p>1"-150# ANSI FLANGE</p> <p>1"-500# ANSI FLANGE</p>

SPECIFICATIONS...

	Design Type	Model Number	Housing Material	Float Material	Flag Material	Max. Pressure	Max. Temperature	Connection	Max. Length of Indication	Max. Overall Unit Length	
STANDARD	D	86195	PVC	PVC	P	40 PSI	140°F (60°C)	Side, 1"-150# Flange	125" (3175.0mm)	12' (3.65m)	
	E	86200	SS-3	304 SS 316 SS	304 SS	P	150 PSI	300°F (149°C)	Top, 3"-150# SS Flange	60" (1524.0 mm) ...	11'5" (3.48m)
			SS-5	304 SS 316 SS	304 SS	P	150 PSI	300°F (149°C)	Top, 5"-150# SS Flange	60" (1524.0 mm) ...	11'3" (3.43m)
			CS-3	CS 316 SS	Buna N	P	150 PSI	180°F (82°C)	Top, 3"-150# CS Flange	60" (1524.0 mm) ...	11'3" (3.43m)
	F	86205	PVC	PVC	P	40 PSI	140°F (60°C)	Top, 3"-150# Flange	60" (1524.0 mm) ...	11'4" (3.45m)	

Ordering Information... Specify the SureSite part number(s) P/N, design type(s) from the charts (above); and 'L' dimension. Use GEMS SureSite Inquiry/Order Sheet for complete ordering specifications and special options required

- P - Plastic
- A - Aluminum
- * 230°F (110°C) Maximum in oil
- ** Other Flange Sizes Available.
- *** Specific gravity of 1.0 and up
- † Mounting Bracket - P/N 36406 recommended on Type 'A' unit only - Over 10' (3.048 m) Length
- †† Use Inverted Units when Float removal MUST COME FROM TOP OF UNIT
- When Inverting Units Type B or C, MIN. Dimension indicated in above drawings must be reversed

VISCOSITY EFFECTS: Increased viscosity increases time response.

- * MINI-Type 1 & MINI-Type 2 - 1" (25.4mm) REF Top and Bottom
- * STANDARD Type A, B & C - 2" (50.8mm) REF. Top and Bottom.
- * STANDARD Type D E & F - 1" (25.4mm) REF Top and Bottom.

**GEMS FabriSite Components,
Easy To Assemble In Your Plant,
To Your Exact Requirements**

GEMS, foremost name in liquid level detection and indication, introduces GEMS FabriSite Components. Available are 4 Flag Assemblies; 3 Float Assemblies; 2 Clamps; 2 Switch Module and Clamp Assemblies. Each component offers quick and easy custom-assembly without the need of any special tools. Components are rugged, stand-up to pressure, shock, and vibration. Use non-magnetic standard 2½" I.P.S. SCH 40 Pipe, 2" I.P.S. SCH 80 Plastic Pipe or

1½" (31.8mm) Dia. Tubing, .083 wall thickness, for MINI FabriSite Casing which is available from your local plumbing distributor, as are all needed fittings. GEMS FabriSite Liquid Level Indicator Assemblies are ideal wherever liquid level indication accuracy is called for. They are safer than sight glass assemblies, and provide greater visibility — will not cloud up — and they have the capability to replace your present sight glass assemblies. Whether you are presently using GEMS Liquid Level Indicators, or have the need to create your own GEMS FabriSite custom system, GEMS high quality FabriSite components and optional custom assemblies deliver both dependability and economy.

**Liquid Level Indicator Assembly
using GEMS FabriSite Components . . .**

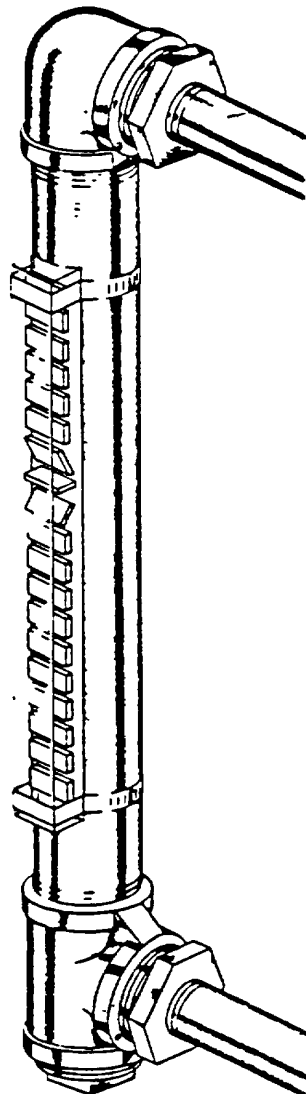

*Patent Pending

TYPICAL INSTALLATIONS . . .

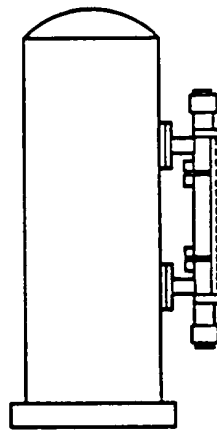

**WATER
TREATMENT**

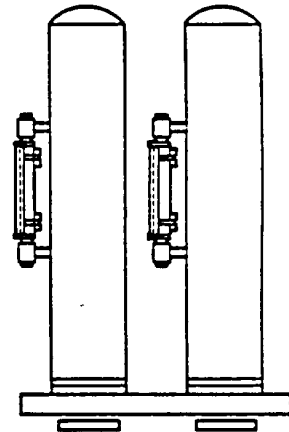

**LIQUID DISTILLING
EQUIPMENT**

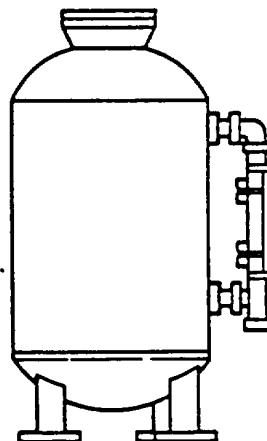

**FOOD PROCESSING
EQUIPMENT**

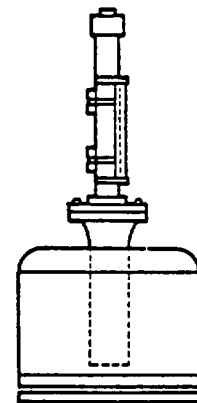





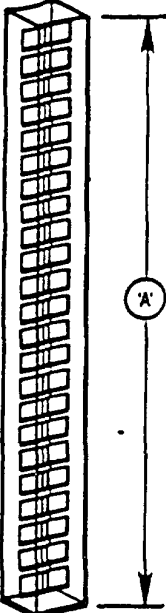

**UNDERGROUND
TREATMENT**

GEMS® LIQUID LEVEL INDICATORS

FabriSite® COMPONENTS

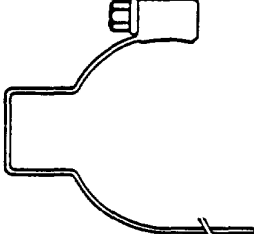
Individual Components Available . . . When ordering — specify part number(s) and quantities required. All components are also available for stocking

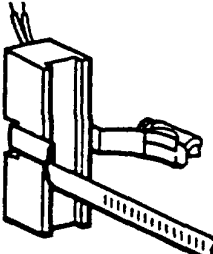
 <p style="text-align: center;">*FLAG ASSEMBLY</p> <table border="1" style="width: 100%; border-collapse: collapse; margin-bottom: 5px;"> <thead> <tr> <th style="text-align: center;">LENGTH "A"</th> <th style="text-align: center;">PART NUMBER</th> </tr> </thead> <tbody> <tr> <td style="text-align: center;">6" (152.4mm)</td> <td style="text-align: center;">72216</td> </tr> <tr> <td style="text-align: center;">1' (304.8mm)</td> <td style="text-align: center;">70411</td> </tr> <tr> <td style="text-align: center;">2' (609.6mm)</td> <td style="text-align: center;">70412</td> </tr> <tr> <td style="text-align: center;">4' (1219.2mm)</td> <td style="text-align: center;">75266</td> </tr> </tbody> </table> <p style="font-size: small;">Material: Polysulfone Max. Temp.: 300 °F (149 °C)</p>	LENGTH "A"	PART NUMBER	6" (152.4mm)	72216	1' (304.8mm)	70411	2' (609.6mm)	70412	4' (1219.2mm)	75266	 <p style="text-align: center;">FLOAT ASSEMBLY P/N 86523</p> <p style="font-size: x-small;">Size: 2½" (57.2mm) Dia. (Nom.) Float Length: 7" (177.8mm) (Ref.) Material: 316SS Max. Temp.: 300 °F (149 °C) Max. Pressure: 600 PSI Specific Gravity: .66</p>	 <p style="text-align: center;">MINI FLOAT P/N 85206</p> <p style="font-size: x-small;">Size: .984 (25.0mm) Dia. (Nom.) Float Length: 6.30" (160.3mm) (Ref.) Material: 304SS Max. Temp.: 300 °F (149 °C) Max. Pressure: 150 PSI Specific Gravity: 0.65 ± .01</p>	 <p style="text-align: center;">PVC FLOAT P/N 87248</p> <p style="font-size: x-small;">Size: 1.78 (45.2mm) Dia (Nom.) Float Length: 6" (152.4mm) (Ref.) Material: PVC Max. Temp.: 140 °F (60 °C) Max. Pressure: 40 PSI Specific Gravity: .63</p>
	LENGTH "A"	PART NUMBER											
6" (152.4mm)	72216												
1' (304.8mm)	70411												
2' (609.6mm)	70412												
4' (1219.2mm)	75266												
 <p style="text-align: center;">STANDARD CLAMP P/N 85579</p> <p style="font-size: x-small;">Size: 2½" (53.9mm) (Ref.) Material: 18-8SS For use with SureSite Standard Indicator — Types A,B,C,D,E,F.</p> <p style="text-align: center;">MINI CLAMP P/N 86139</p> <p style="font-size: x-small;">Size: 1½" (44.5mm) (Ref.) Material: 18-8SS For use with SureSite Mini Indicator — Types 1, 2.</p>	 <p style="text-align: center;">SWITCH MODULE P/N 85350</p> <p style="font-size: x-small;">Size: 3½" (88.9mm) (Ref.) Material: Polysulfone Max. Temp.: 300 °F (149 °C)</p>												
 <p style="text-align: center;">STANDARD SWITCH MODULE WITH CLAMP P/N 86435</p> <p style="text-align: center;">SWITCH MODULE WITH MINI CLAMP P/N 86567</p>													

NOTES:

1. See Pages 4 and 5 for approximate FabriSite Fabrication Dimensions.
2. When ordering components — Specify Part Number(s) and quantities required. All components are available for stocking
3. Pipes must be non-magnetic including welding material Bore must be smooth and dirt-free.
4. With metal pipe use 2½" I.P.S. non-magnetic schedule 40 for Standard Series or 1½" (31.8mm) Dia., .083 wall thickness for Mini Series
5. With plastic pipe use 2" I.P.S. schedule 80

*Patent Pending

6. Units are designed for use with liquid specific gravities from 0.75 to 1.1. Maximum differential between liquid and Flag position can be 1.6" depending on specific gravity of liquid.
7. Using above floats within specific gravity ranges (Note 6) will provide a safe condition from spilling since Flags will indicate exact level or higher level.
8. Switch assemblies must be directly opposite Flag assembly for proper operation. ROLI Transmitter assembly may not be used with SureSite Mini Series or FabriSite.
9. Two clamps are recommended for each Flag assembly or every 24" (609.6mm) on longer assemblies
10. See pages 8, 9, 10 and 11 for SureSite, FabriSite options

GEMS 'ROLI' Transmitter
for SureSite Liquid
Level Indicators — P/N 85875

Principle of 'Roli' Transmitter operation — A Float moves with liquid level inside SureSite casing along the Transmitter containing a Voltage Divider to vary a tapped-off Electrical Signal which is transmitted to an Indicating Meter or a Signal Conditioner. This signal, and therefore the readout, are proportionate to the level of the liquid.

Transmitter Housing: Polysulfone. **3 Conductor Cable:** 22 Gage Standard 7/30 in PVC Jacket.

Transmitter Resolution: 1" (25.4mm) Max. Accuracy: $\pm 1"$ (25.4 mm), Non-Cumulative. Max. Temp.: 225 °F (129 °C). Recommended Minimum Loading Ratio = 20:1

Therefore $\frac{IR-B}{IW} = 20$.

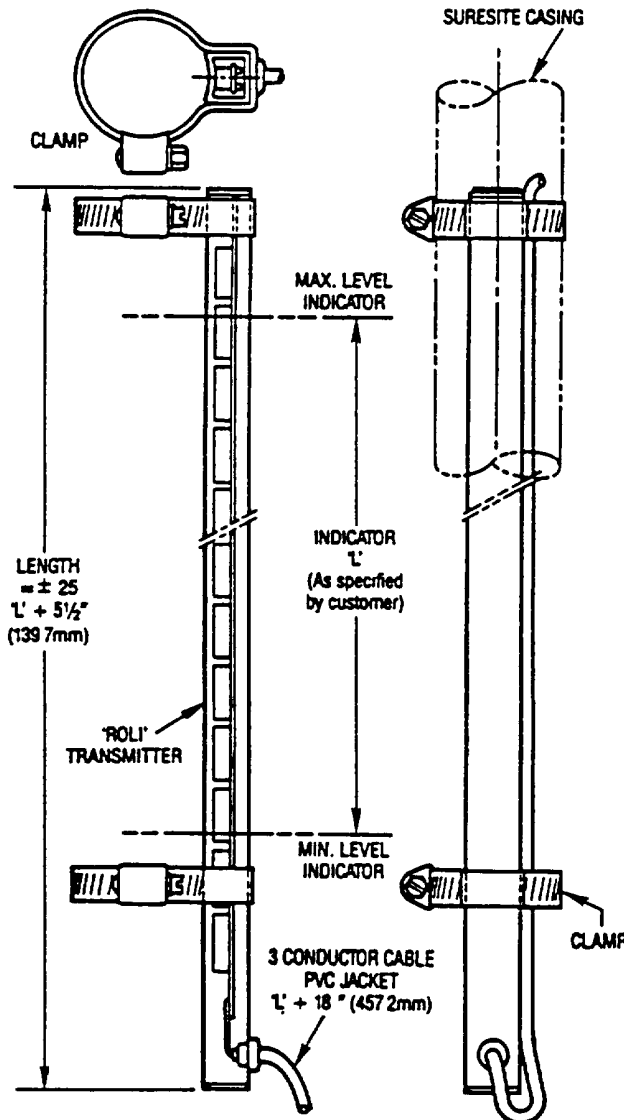

Transmitter Principle of Operation

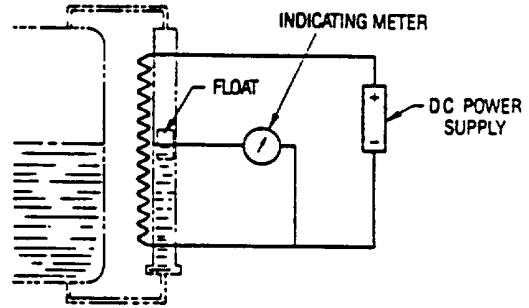

Basic Transmitter System

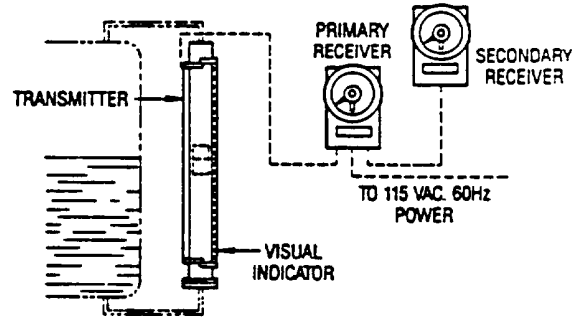

Wiring Diagram

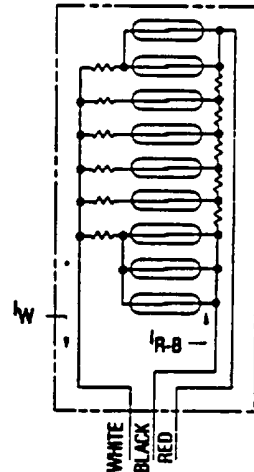

NOTES:

1. Transmitter option NOT available on SureSite Types D,F and Mini Units or FabrSite.
2. The Transmitter is positioned opposite of Flag assembly. Locate at 180° from Flag channel.
3. When ordering 'Roli' Transmitter — Specify Part Number(s) and quantities required. Also specify inches of indication. (Must be given in 1" (25.4mm) increments).
4. Signal output may not always increase in a continuous positive mode.

GEMS® LIQUID LEVEL INDICATORS SureSite® OPTIONS

GEMS Meter/Receiver Station Type RE-77500

Gems Meter/Receiver is designed for mounting in either singular or multiple panel arrangements. Receiver can be used in conjunction with Gems continuous type transmitter and 'Roli' transmitter on SureSite liquid level indicators.

Various models are available. Some features will include built-in or remote power supply Hi-Lo alarm contacts for remote alarms. Lights to indicate alarm set points for Hi-Lo alarms.*

Connections will also be available for secondary or remote meters. Blank or marked meter faces will be available based on information supplied by customer.

*When used with 'Roli' type transmitter, alarm points may fluctuate depending on voltage signal output, since signal output may not always increase in a continuous positive mode.

Features Available . . .

1. Hi and Lo Alarm Contacts.
2. Various Input Voltages: 24 VDC; 115 VAC; 230 VAC.
3. Indicating Lights.
4. Panel Mounting.
5. Ease of Adjustment.
6. Blank or Marked Meter Faces.

Consult GEMS For Modular Receiver requirements to meet your specific needs.

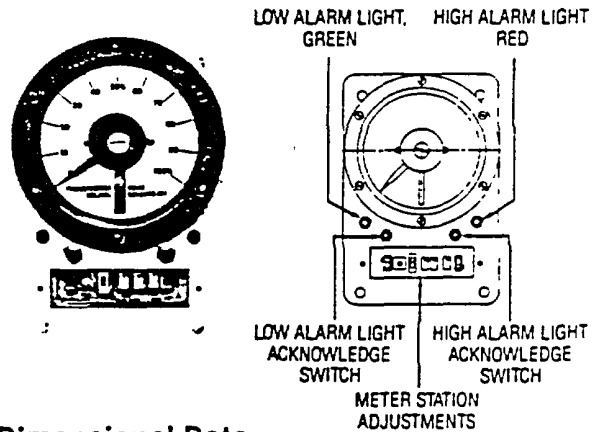

Dimensional Data . . .

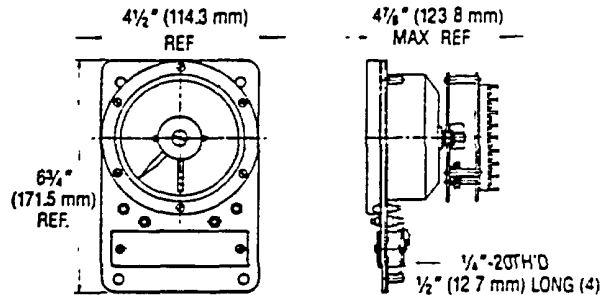

GEMS Modular-Conditioned Transmitter J-Box Outputs and Functions

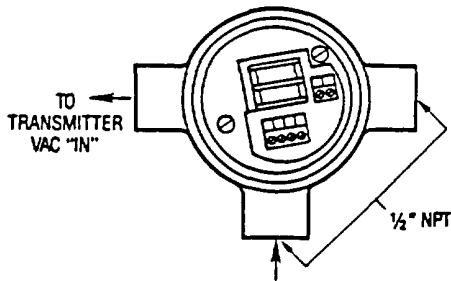

Transmitter J-Box output configuration with built-in power supply

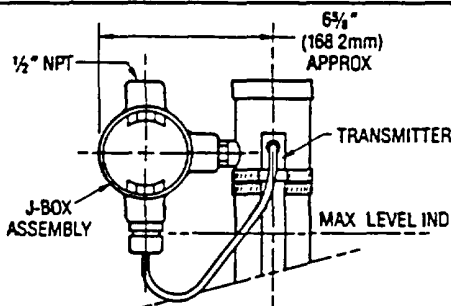

Transmitter J-Box output configuration mounted to Type 'A' SureSite unit

A variety of GEMS electrical Junction Boxes with built-in Terminal Block or Signal Conditioners are available for most GEMS SureSite units.

PART NUMBER	INPUT SOURCE/V	CONFIGURATION	OUTPUT SIGNAL
86140	—	Terminal Block	—
86156	8-24 VDC	Signal Conditioner	0-5 VDC
85997	14-30 VDC	Signal Conditioner	0-12 VDC
86157	18-30 VDC	Signal Conditioner with Alarms	0-12 VDC
86158	10-40 VDC	Two Wire Converter	4-20 MA
52560	115 VAC	Power Supply	24 VDC
52570	230 VAC	Power Supply	24 VDC

For additional options available, consult GEMS SENSORS DIVISION.

GEMS® LIQUID LEVEL INDICATORS

SureSite®, FabriSite® OPTIONS

Optional GEMS Switch Modules for SureSite Liquid Level Indicators . . .

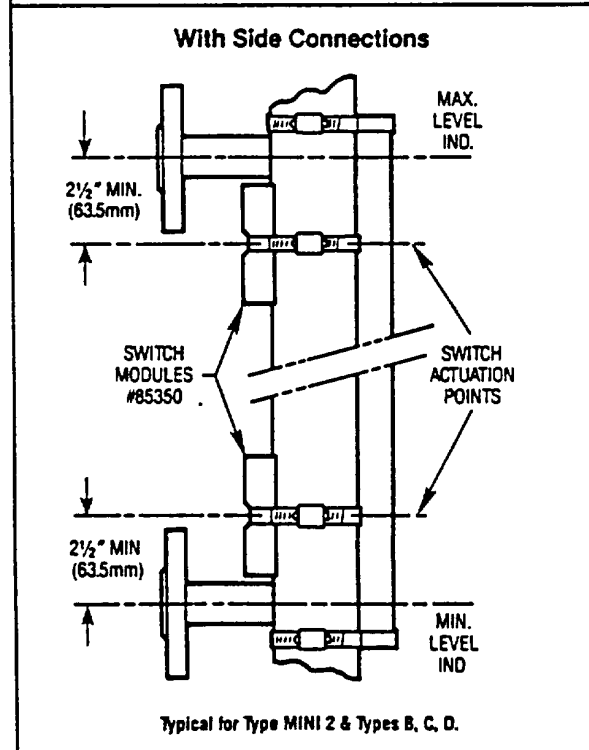
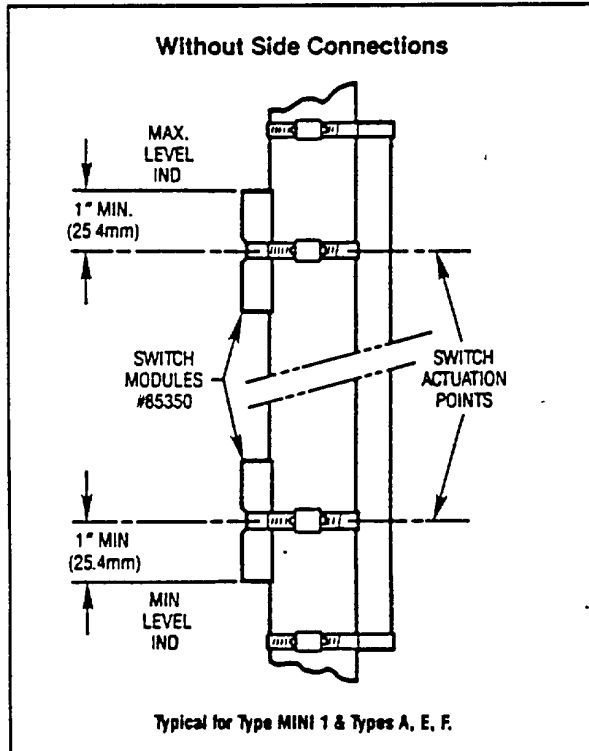

Optional Switch Modules can be used with GEMS SureSite Indicators as alarm and/or control logic. Dimensions for locating switch modules on SureSite unit housing are shown in illustrations on left.

Switch Module Operation:

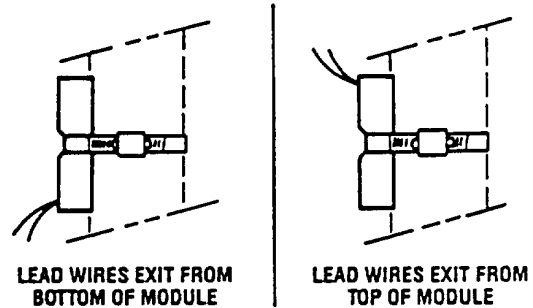

Switch Module Logic:

1. Switch mounted with lead wires exiting from top of module — switch closes on rising level and remains closed until falling level opens switch again.
2. Switch mounted with lead wire exiting from bottom of module — switch opens on rising level and remains opened until falling level closes switch again.

NOTE:

1. Switch modules may be located between specific Hi and Lo alarm levels noted. Minimum distance between individual switch modules is 3/4" (88.9mm).
2. Correct switch module position on unit housing should be 180° from flag indication rail.
3. Switches are SPST-20VA, latching reed type; N.O or N.C.

GEMS High Temperature Switch Module — P/N 85825

High Temperature Switch Module should be used with SureSite Types A, B, C, D, E and F Liquid Level Indicators only.

Switch is SPST — 20VA, Latching Reed Type, N.O. or N.C. For Switch Module Logic see 1 and 2 above.

Max. Temp.: 500°F (260°C).

Material: Aluminum. Comes with 3 Conductor Cables — 10' (3.05 m) long.

High Temperature Switch Module is available with Clamp Assembly (18-8SS) . . . Use P/N86440 when ordering.

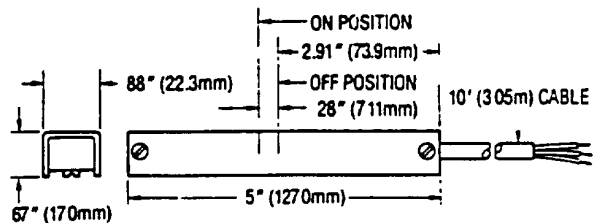

GEMS® LIQUID LEVEL INDICATORS

SureSite®, FabriSite® OPTIONS

GEMS Indicating Scale — P/N 85555

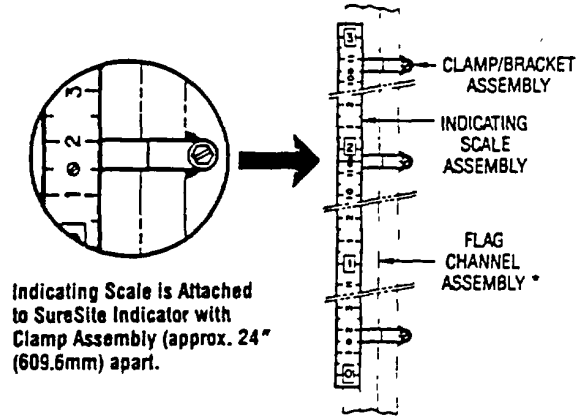

Available when in addition to Flag indication, numerical indication is required. Graduations marked in inches and feet. Scale is made of aluminum. It's attached to Flag Assembly with special bracketed clamps — See illustration on left. 2 Clamp assemblies are available. When ordering indicate P/N and Length required.

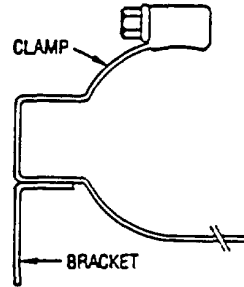

CLAMP ASSEMBLIES . . .
For SureSite Indicators Type A thru F refer to clamp assembly — P/N85733

For SureSite Indicators Mini Series — Type 1 & 2 refer to clamp assembly — P/N85734

GEMS Accessory Modular Alarm Panels

Multiple alarm functions for a wide variety of instrumentation control applications are conveniently grouped and displayed on these compact, modular units. GEMS alarm panels provide a built-in, audible alarm and six independent alarm lights for actuation by up to six separate switch closures . . . flow, level, pressure or any other dry contact type.

Contacts are provided for connection of a remote alarm, which sounds whenever the local audible alarm on the panel is actuated. An alarm silencing switch (on the panel) silences both local and remote alarms. The single, local audible alarm and remote alarm contacts serve all six alarm stations

Use of GEMS zener barriers with these alarm panels, which are located in a non-hazardous area, provides intrinsic safety for non-voltage-producing sensors located in hazardous areas.

Two standard models . . . Differing alarm light operation, only:

Model P/N 32915 . . . When an alarm switch closure is applied, the related light on the panel turns "on" and the audible alarm sounds. Depressing the alarm silencing switch silences the audible alarm, and the light remains "on" until the alarm condition is cleared.

Model P/N 58938 . . . When an alarm switch closure is applied, the related light on the panel begins flashing and the audible alarm sounds. Depressing the alarm silencing switch silences the audible alarm. The light will continue to flash until the light lens is "pressed to acknowledge". The light will then revert to steady "on" until the alarm condition is cleared

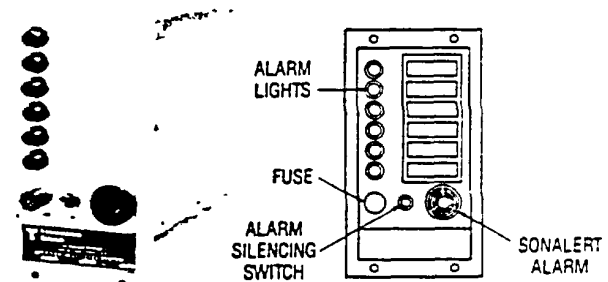

Dimensional Data . . .

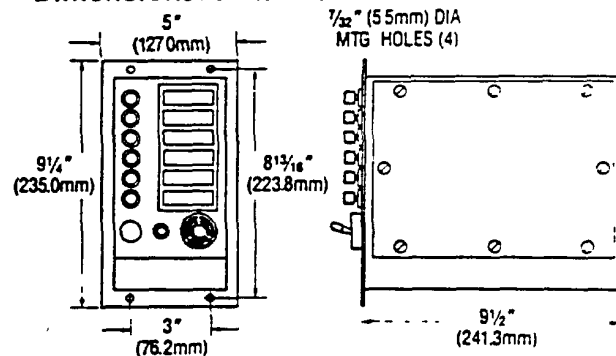

Specifications . . .

	P/N 32915*	P/N 58938*
Input Power	109 to 121 VAC, 60 Hz	115 VAC, ± 10%, 47 to 440 Hz
Operating Temp.	+ 32° to + 140°F (0° to 60°C)	
Light Assemblies	Press to test	Press to acknowledge
Audible Alarm Output	80 db at 2 ft.	
Remote Alarm Contact Rating	Internally powered 115VAC, 1 amp, resist.	

Construction . . .

Units are ruggedly built throughout. All controls and labeling for alarm functions are grouped on the front panel for easy reading and accessibility.

* Note: When alarm panels are used with zener barriers:

Unit P/N 32915 . . . Use with GEMS Zener Barriers P/N 50635, 54804 or 54807 only

Unit P/N 58938 . . . Use with GEMS Zener Barriers P/N 50625 or 54806 only

Installation . . .

Accessory racks are available for simple panel- or wall (bulk-head)-mounting. All cable connections are located on the underside of the unit housing

*Patent Pending

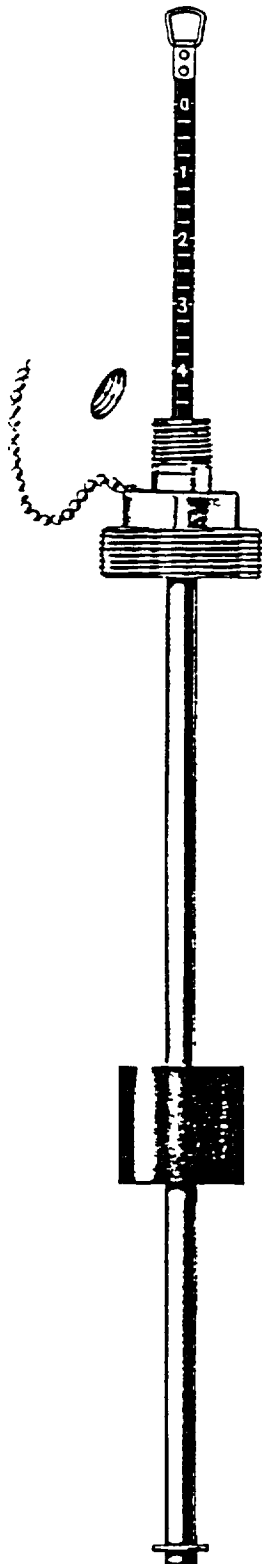

**Accurate, non-electrical,
liquid level indicator for
drums, vats, small storage
tanks . . .**

The GEMS DIPSTICK Series are compact, entirely self-contained, liquid level indicating units, designed primarily for use in storage drums, vats, tanks, etc. Non-electrical and manually actuated, these units work anywhere . . . in any environment . . . no power necessary. The DIPSTICK is ideal for accurate, "on-the-spot" level readout in a wide variety of storage vessels . . . in locations where power is not available. Units are available in standard models . . . and as "specials" in various lengths, mounting types and floats. (See "Options Available").

DRUMSTICK models (included in the GEMS Dipstick series) are supplied in a choice of standard materials for compatibility with most liquids and chemicals. Only the float and stem assembly contact the liquid. Units 22" (558.8mm) or 33" (838.2mm) in length for 55 gallon drums and 17 1/2" (444.5mm) or 26 1/2" (673.1mm) in length for 30 gallon drums, with 2" NPT mountings, are standard.

Simple, Manual Operation . . .

A magnet-equipped float moves with liquid level along the unit stem, inside the storage vessel. Level readout is obtained by simply removing the protective cap atop the unit and lifting the calibrated indicator (within the unit) until magnetic interlock with the float is felt. The indicator is held at this point and level is read where the calibration aligns with the top of the unit mounting. The indicator is then lowered back inside the unit for storage and is protected by the screw type cap when not in use.

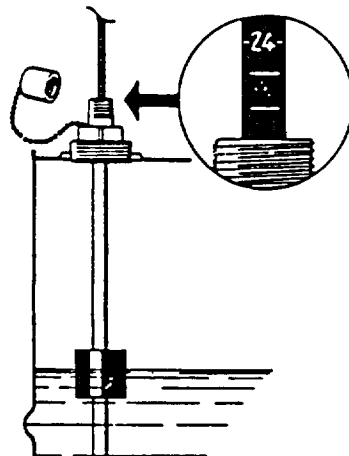

Specifications . . .

**DIPSTICK
Units**

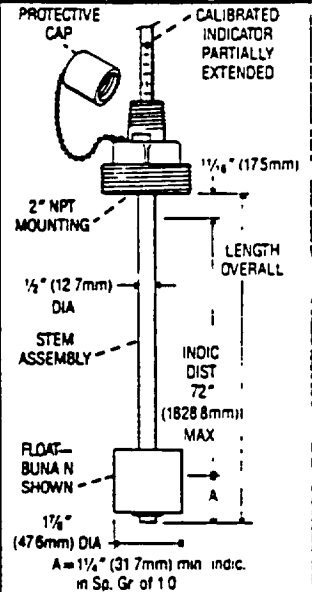

Stem & Mtg. Material	Brass or 316 SS
Float Material	Buna N or 316 SS
Mounting	2" NPT
Operating Temp. Range	+ 33°F (0.1°C) to + 180°F (82°C) Water 0°F (- 17.8°C) to + 230°F (110°C) Oil
Operating Pressure, Max.	150 psi—w/Buna N Float 750 psi—w/316SS Float
Indicating Length	6" (152.4mm)-72" (1828.8mm)
Std. Indic. Markings	Inches (1/4" increments)

Applications . . .

- Standard drums (typically 30 to 55 gallons) storing virtually any type of liquid.
- Storage tanks for chemicals, lube oils, fuels, etc.
- Pressure vessels . . . hazardous liquid storage drums or tanks . . . operation does not open or disturb the tank.
- Wherever a quick, periodic check of liquid level is required, and power is not at hand.

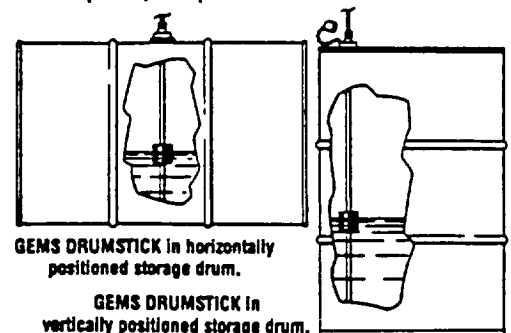

GEMS DRUMSTICK in horizontally positioned storage drum.

GEMS DRUMSTICK in vertically positioned storage drum.

GEMS® LIQUID LEVEL INDICATORS DIPSTICK

<p>PROTECTIVE CAP CALIBRATED INDICATOR PARTIALLY EXTENDED 3/4" (19.05mm) 3"-150# ANSI FLANGE MOUNTING 1/2" (12.7mm) DIA STEM ASSEMBLY INDIC DIST 72" (1828.8mm) LENGTH OVERALL FLOAT—316SS SHOWN 2" (50.8mm) DIA A=1 3/4" (34.9mm) min indic in Sp Gr of 10</p>	<p>PROTECTIVE CAP CALIBRATED INDICATOR PARTIALLY EXTENDED 3/4" (6.4mm) 2" NPT MOUNTING 1/2" (12.7mm) DIA STEM ASSEMBLY INDIC DIST 72" (1828.8mm) MAX LENGTH OVERALL FLOAT—PVC SHOWN 1 1/2" (38.1mm) DIA A=1 1/8" (47.6mm) min indic in Sp Gr of 10</p>	<p>PROTECTIVE CAP CALIBRATED INDICATOR PARTIALLY EXTENDED 1 1/8"-PP 1/2"-PVDF 1 1/8"-PVC 3"-150# ANSI FLANGE MOUNTING 1/2" (12.7mm) DIA STEM ASSEMBLY INDIC DIST 72" (1828.8mm) MAX LENGTH OVERALL FLOAT—PVC SHOWN 3" (76.2mm) DIA 1 1/4"-PP 2 3/8"-PVDF 1 3/4"-PVC</p>	<p>PROTECTIVE CAP CALIBRATED INDICATOR PARTIALLY EXTENDED 1 1/8"-PP 1/2"-PVDF 1 1/8"-PVC 3" NPT MOUNTING 1/2" (12.7mm) DIA STEM ASSEMBLY INDIC DIST 72" (1828.8mm) MAX LENGTH OVERALL FLOAT—PVC SHOWN 3" (76.2mm) DIA 1 3/8"-PP 2 3/8"-PVDF 1 3/4"-PVC</p>
316 SS	PVC	PVC, PVDF, Polypropylene	
Buna N or 316 SS	PVC	PVC, PVDF, Polypropylene	
3" 150#—Carbon Stl. Flange 3" 150#—316 SS Flange	2" NPT or 3" 150# Flange	3" 150# Flange	3" NPT
0°F (-17.8°C) to +300°F (149°C)	0°F (-17.8°C) to +140°F (60°C)	+40°F (0.5°C) to 140°F (60°C)	
150 psi—w/Buna N Float 750 psi—w/316SS Float	15 psi	50 psi	
6" (152.4mm)-72" (1828.8mm)		6" (152.4mm)-72" (1828.8mm)	
Inches (1/4" increments)		Inches (1/4" increments)	

Standard DRUMSTICK Models ...

Mounting	2" NPT		2" NPT	
	55 Gallon		30 Gallon	
Drum Size	55 Gallon		30 Gallon	
Drum Position	Horiz.	Vert.	Horiz.	Vert.
DRUMSTICK Length Overall	22" (558.8mm)	33" (838.2mm)	17 1/2" (444.5mm)	26 1/2" (673.1mm)
Brass/Buna N	P/N 71150	P/N 71152	P/N 71149	P/N 71151
Stainless Steel	P/N 71146	P/N 71148	P/N 71145	P/N 71147
PVC	P/N 71142	P/N 71144	P/N 71141	P/N 71143

Construction ...

GEMS DIPSTICK Series units are exceptionally rugged throughout, with brass, stainless steel, PVC, PVDF or Polypropylene stem assemblies, Buna N, stainless steel, PVC, PVDF or Polypropylene floats standard.

Installation and Maintenance ...

Units are installed through the tops of either vertically or horizontally positioned drums or tanks. DIPSTICK Series units can be supplied in lengths as specified for the application ... for up to 72" (1828.8mm) of indication. Maintenance is minimum ... only occasional "wipe-down" cleaning if the liquid is excessively contaminated.

DIPSTICK Options Available ...

NPT mountings in various sizes; straight thread mountings, flange mountings in various sizes; various floats and special indicator markings are available in large OEM quantities

Ordering Information ...

Select the DRUMSTICK part number(s) P/N design type (or types) from the Standard Models chart (above) Use GEMS DIP STICK Inquiry/Order Sheet (or sheets) to completely specify each unit, along with any special options required, when ordering.

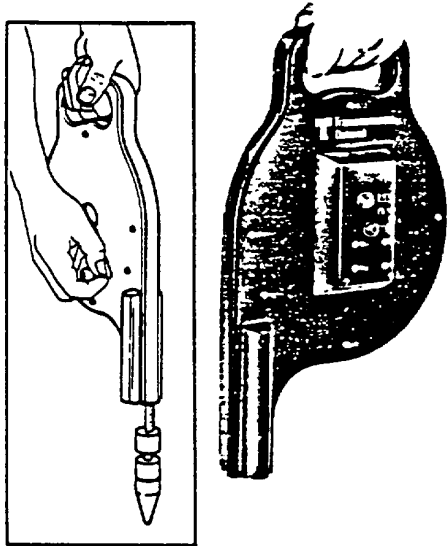
Models Available:

P/N 45300 with 50' (15.24m) tape
P/N 45500 with 100' (30.48m) tape.

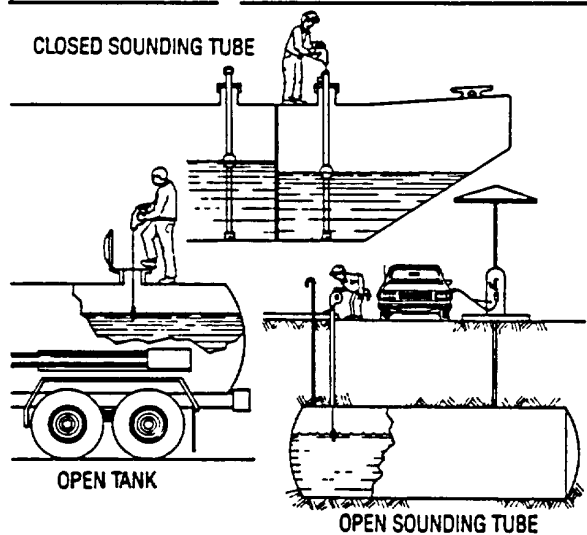
Class I, II & III Applications:
Marine Industry

Shipboard service tanks — Navv ships, Commercial/Marine

Land based tanks — Undergroup tanks

Interface tanks — Both shipboard and land based

Cargo tanks — Barges, tanker ships — Closed loading

Commercial Use

Storage tanks — For lube oils, fuels, etc.

Railroad and truck tankers

Gas Station underground tanks

Water interface detection

Wherever quick checking of liquid level is required

**Direct and Accurate Reading.
Compact, Versatile, Economical.**

Designed for use in either enclosed or open sounding tubes, or in open tank, GEMS highly versatile new self-contained ullage indicator is ideally suited for Naval, Maritime and Commercial Industries — tankers, storage tanks, barges, underground tanks, etc. Unit housing is made of polypropylene, completely portable and requires no power — works on a 9 VDC battery. It can be used as its own sounding system, or as an accessory to some existing level indicated system (Consult GEMS for proper float, float stop and sounding tape) All parts are intrinsically safe for hazardous liquids and chemicals. An ideal low cost method to determine liquid level wherever the unit is compatible.

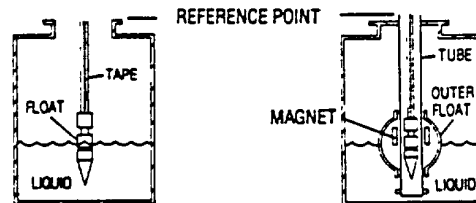
Operating Principle:

DIRECT READING

A self-contained TAPE GUN is equipped with a hand crank for raising and lowering measuring tape/plumb bob assembly to liquid to be measured. A magnet equipped float moves with liquid level to actuate a magnetic reed switch housed within brass plumb bob. Closure of reed is signalled by RED L.E.D. (light emitting diode) located adjacent to the on/off switch. When light comes on operator identifies point on measuring tape to determine ullage (space left in tank) or through a calculation determining liquid level.

INDIRECT READING

A sealed non-magnetic pipe (1" IPS SCH 40) or 1 1/2" (31.7 mm) tubing (available from GEMS) is installed along with a magnet equipped float (supplied by GEMS). The sealed tube isolates the liquid, vapors, pressure and temperature within tank from the operator and outside environment. The brass plumb bob/tape assembly are lowered into tube until read switch comes into proximity with outer float. Magnets within outer float close reed, signalling RED L.E.D and OPERATOR. Reference is made at top of tube.

Features:

Accuracy — Tape is divided into 1/8" increments.

Repeatability — Float moving along plumb bob will close reed switch within plumb bob's stem consistently — at the same point.

Compact — Weighs less than 5 pounds. Goes anywhere and easy to store.

Versatility — Different floats for different applications. Standard Buna "N" Float is supplied to take direct surface or indirect readings. Interface float to give an oil/water or gas/water interface within tank.

Virtually Maintenance Free — 9 VDC battery is only power requirement. (Has battery tester).

Self-Checking Integrity — By lifting float along the plumb bob, battery operation, and/or if reed switch within stem has sustained any damage can be determined.

FM Approved Intrinsically Safe — For hazardous locations. FM Rating — Class 1, Division 1, Groups C and D.

Coast Guard Accepted — For closed loading applications.

GEMS® LIQUID LEVEL INDICATORS SOUNDING TAPE

Specifications . . .

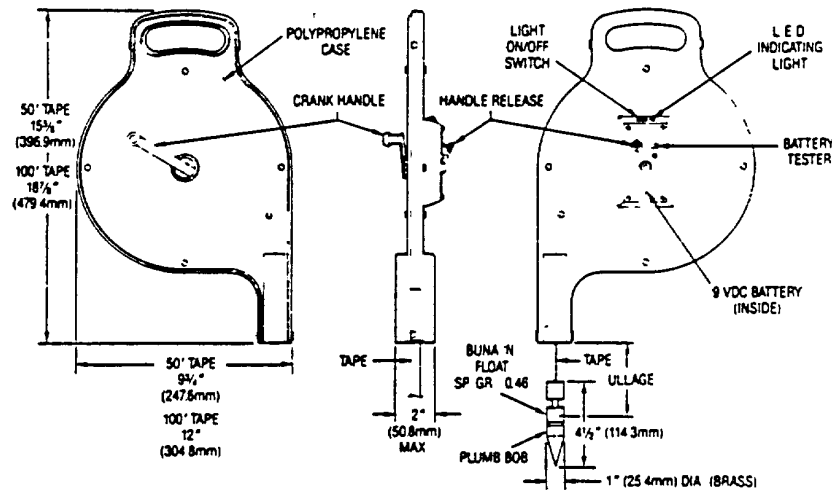

Available . . . Closed Sounding Tube Equipment

SOUNDING TUBE

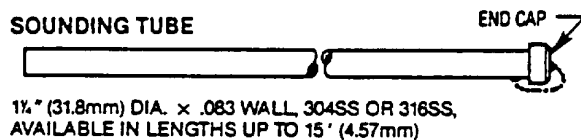

1 1/4" (31.8mm) DIA. x .083 WALL, 304SS OR 316SS,
AVAILABLE IN LENGTHS UP TO 15' (4.57mm)

FLOAT STOP COLLAR

FOR USE ON 1 1/4" (31.8mm)
DIA. TUBE, 304SS.

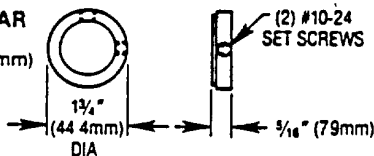

P/N 26703

FLOATS (FOR USE ON 1 1/4" (31.8mm) DIA. TUBE)

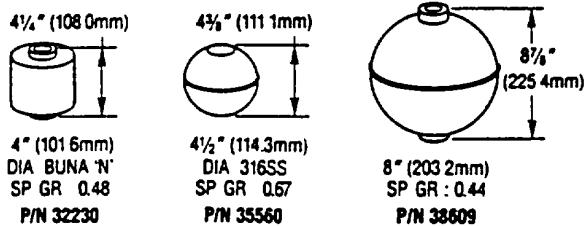

4" (101.6mm)
DIA BUNA 'N'
SP GR 0.48
P/N 32230

4 1/2" (114.3mm)
DIA 316SS
SP GR 0.67
P/N 35560

8" (203.2mm)
SP GR : 0.44
P/N 38609

ORDERING INFORMATION:

When ordering SOUNDING TAPE GUN specify Part Number(s) P/N and quantities required. For additional technical data or optional operation method of sounding tape . . . please consult GEMS Sensor Division.

ULLAGE: Empty space from top of tank and/or stand pipe to surface of liquid inside of tank.

EXAMPLE:

Tape Reading = 72"
(1828.8mm) — Tank
Depth @ Sounding
Tube — 100" (2540.0mm)
= Net 28" (711.2mm)
Liquid.

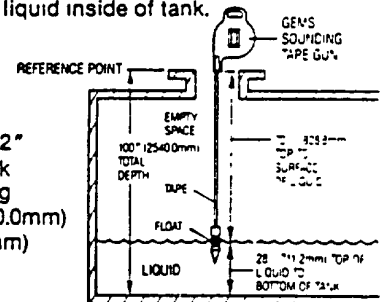

NOTE: For open sounding tube applications, tube to be customer supplied — 1" IPS SCH 40 pipe or larger

CHANGING BATTERY:

Simply remove four screws on light housing allowing access to 9 VDC battery. Where intrinsically safe FM approved units only the following batteries can be used as replacements

DURACELL MN1604, EVEREADY 1222, RAY-O-VAC 1604

Warnings & Cautions:

1. Product must be maintained and installed in strict accordance with the GEMS technical brochure and installation, operation and maintenance bulletin. Failure to observe this warning could result in serious injuries or damages.
2. The pressure and temperature limitations shown on the individual catalog pages and drawings for the specified Liquid Level Indicators must not be exceeded. These pressures and temperatures must take into consideration possible system surge pressures/temperatures and their frequencies
3. For hazardous area applications involving such things as (but not limited to) ignitable mixtures, combustible dust and flam-

mables, use an appropriate explosion-proof enclosure or intrinsically safe interface device

4. The liquids used must be compatible with the materials of construction. Specifications of materials will be given upon request.
5. Trouble-shooting and maintenance of Liquid Level Indicators should be in strict compliance with procedures set forth in the trouble-shooting and maintenance sections of the technical brochure or an installation, operation and maintenance bulletin.

OTHER HIGH-RELIABILITY PRODUCTS OF GEMS SENSORS DIVISION

LEVEL CONTROL...

Gems Liquid Level Switches provide maximum accuracy and dependability for high, low or intermediate point level detection in practically any tank or vessel, liquid or environment. Compact, single-station units for widely varying liquid viscosities ... UL-recognized models available.



LS-800 Series Level Switches ... single or multi-level ... are built for specific requirements. Gems Fabri-Level lets you custom-assemble a multi-level unit to exactly suit your application.



CONTINUOUS LIQUID LEVEL INDICATION...

GEMS transmitters and indicators continuously and accurately monitor levels in just about any liquid, tank or vessel. Complete transmitter-receiver systems ... transmitters with signal-conditioned, DC outputs for direct interface with terminal equipment ... Solar-powered units ... give GEMS TLI exceptional versatility.

36000 Series Transmitters are accurate to within $\pm 1/2$ " of true level, regardless of tank depth. Transmitter-receiver systems with all controls, and signal-conditioned transmitters with 0-5V, 0-12V and 4-20ma DC outputs are available with a variety of alarm controls.

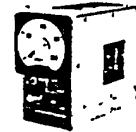

FLOW CONTROL...

GEMS Flow Switches provide high-reliability flow detection for liquids or gases at pressures to 1000 PSIG. Wide range of flow settings ... fixed and adjustable. Port sizes from $1/4$ " to 3" NPT ... simple, "pipe-fitting" installation.



Continuous Flow Control...

Flow Transducers continuously monitor liquid flow, 1-10 VDC output is directly proportional to flow rate. Units interface directly with wide variety of indicating equipment.

FS-65090 PVC Flow Switch ... low cost, positive, flow/no flow protection ... ideal for high volume OEM usage.



SOLID-STATE RELAYS AND BARRIERS FOR INTRINSIC SAFETY...

GEMS SAFE-PAK® renders any non-voltage producing sensor or switch intrinsically safe for hazardous locations. GEMS Programmable SAFE-PAKS let you program switching mode ... N.O. or N.C. ... at installation. GEMS Zener Barrier SAFE-PAKS provide intrinsically safe outputs to sensors in hazardous areas. Broad range of approvals ... FM, UL, CSA, etc.

Non-intrinsically-safe GEMS Solid-state LOAD-PAKS ... FLIP-PAKS ... control high-voltage loads with a few milliamps of sensor current.

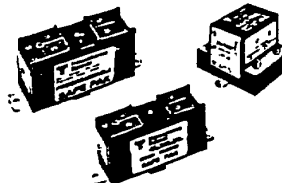

GEMS SAFE-PAKS and Zener Barrier SAFE-PAKS



GEMS LOAD-PAK and FLIP-PAK

FOR SALES AND SERVICE...offices at these locations:

*LOS ANGELES	CALIFORNIA	213/868-2268	*CHARLOTTE	NORTH CAROLINA	704/376-5823
*SAN FRANCISCO	CALIFORNIA	415/342-3350	*CINCINNATI	OHIO	513/489-5300
HARTFORD	CONNECTICUT	203/563-3737	*CLEVELAND	OHIO	216/333-1805
WASHINGTON	DC	301/459-7521	*TULSA	OKLAHOMA	918/663-7231
ATLANTA	GEORGIA	404/261-7063	*PHILADELPHIA	PENNSYLVANIA	215/674-1697
*CHICAGO	ILLINOIS	312/681-4806	*PITTSBURGH	PENNSYLVANIA	412/343-5666
NEW ORLEANS	LOUISIANA	504/466-8504	*FT. WORTH	TEXAS	817/860-4242
DETROIT	MICHIGAN	313/585-8200	*HOUSTON	TEXAS	713/448-1337
ST. LOUIS	MISSOURI	314/567-4005	*SEATTLE	WASHINGTON	206/241-8812
NEW YORK	NEW YORK	212/517-9490 (N.Y.)	*MILWAUKEE	WISCONSIN	414/321-1103
		201/94-8315 (N.J.)	*MISSISSAUGA	ONTARIO, CANADA	416/678-6141

*GEMS products are carried in stock at these offices.

**Transamerica
Delaval**

TRANSAMERICA DELAVAL INC. GEMS SENSORS DIVISION
Cowles Road
Plainville, Connecticut 06062-9990, U.S.A.
Tel. 203-677-1311 Telex 99306
For Application Information: 800-321-6070
(In Ohio, 800-441-7733)

ISSUE	A	B	C	D	E	F	G	H	J	K	L	M	N	P	Q	R	S	T	U	V	W	X	Y	Z	TOTAL
-------	---	---	---	---	---	---	---	---	---	---	---	---	---	---	---	---	---	---	---	---	---	---	---	---	-------

DWG. NO. 87707 REV A

- ① transmitter must be 125° counter clockwise from the flag assembly
- ② switch capsule must be 180° from the flag assembly.

REVISIONS				
CDN.	LTR.	DESCRIPTION	DATE	APPROVED
85-672	A	ADDED "TOP VIEW"	8/20	Rtr

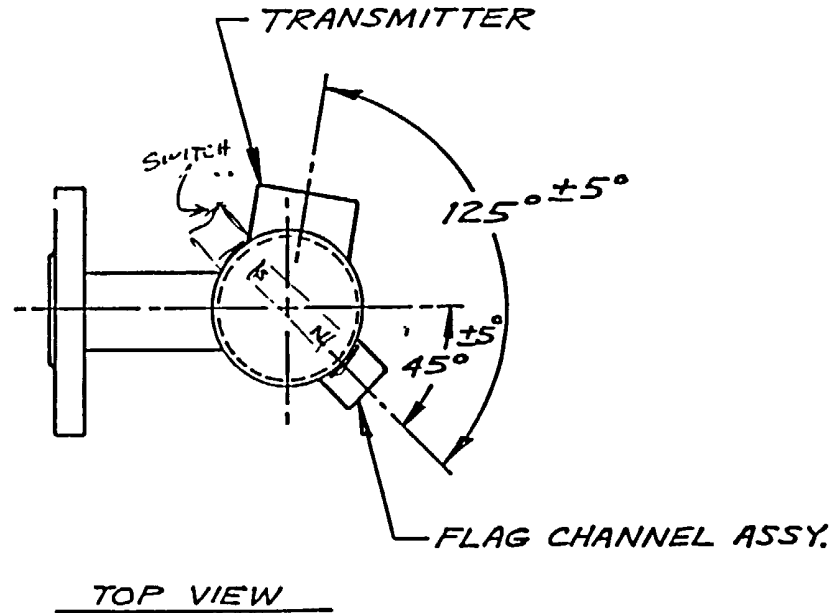

		UNLESS OTHERWISE SPECIFIED, DIMENSIONS ARE IN INCHES.	CONTRACT NO.		TRANSAMERICA DELAVAL INC GEMS SENSORS DIVISION PLAINVILLE, CONN 06062			
			CUSTOMER		Transamerica Delaval			
		TOLERANCES EXCEPT AS NOTED: DECIMAL .XX ± 0.10, .XXX ± 0.05 FRACTIONAL ± 1/64" ANGULAR ± 2° MACHINE FILLETS AND BREAK MACHINED EDGES .005 - 0.015	DWN.	DATE				
			S. PUPECKI	5/24/85				
NEXT ASSY.	USED ON	MATERIAL	CHKD.	DATE	SIZE	CODE IDENT. NO.	DWG. NO.	REV.
APPLICATION			DPD	5/28/85	A	04034	87707	A
DRAWING LEVEL			Rtr	5-28-85	SCALE	NONE	SHEET 3 OF 3	

REV	ECO NO.	DESCRIPTION OF CHANGE	DRN	CHK	DES	PROJ	REL
A		HEADER WAS 22446-1, ADDED JUMPER @ +IN -EX 1 MGD. CAL	JFW		WVG	WVG	L-20 85

NOTES:

- ① CUSTOMER SUPPLIED.
- ② SEE SHT. 3, FOR SENSORS,
‡ ADDITIONAL HARDWARE.

MOUNTING RECOMMENDATION:

1) MOUNT VERTICALLY IN TANK AS ACCESS REQUIRES.

WIRING:

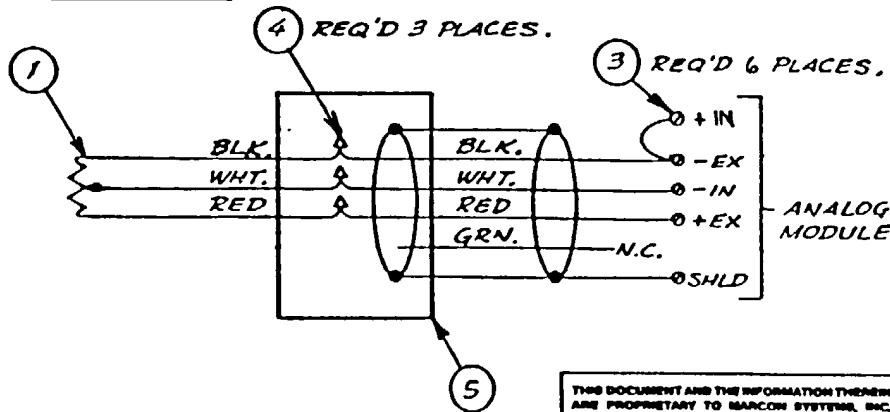

THIS DOCUMENT AND THE INFORMATION THEREIN ARE PROPRIETARY TO MARCON SYSTEMS, INC. AND SHALL BE USED ONLY FOR THE PURPOSES OF SUBMITTAL TO YOU. FURTHER, THIS DOCUMENT AND THE INFORMATION THEREIN SHALL NOT BE REPRODUCED, OR ENCLOSED IN WHOLE OR IN PART TO OTHERS WITHOUT THE WRITTEN PERMISSION OF MARCON SYSTEMS, INC.

ITEM	PART NUMBER	QTY	DESCRIPTION	REF DES
5	①	1	Box - SPLICE	
4	①	6	SPLICE - CRIMP, CLOSED END	
3	①	4	TERMINAL - #6 RING LUG	
2	22368	①	CABLE - 4 COND. W/SHIELD	
1	TLI	②	SENSOR	

MATERIAL LIST

UNLESS OTHERWISE SPECIFIED:	DRN	MARCON SYSTEMS, INC.	
DIMENSIONS ARE IN INCHES.	CHK	BELLEVUE, WASH. 98005	
TOLERANCE	DES	DWG. TITLE:	
FRACTIONS = 2/16	PROJ	SENSOR SPECIFICATION:	
DECIMALS = .001	WVG	GENERAL,	
ANGLES = ± 1/2°	REL 12-8-83	CODE IDENT NO	SIZE
		B	23235
MODEL	NEXT ASSY	SCALE	DO NOT SCALE DWG
			SHEET 1 OF 3

DWG NO 23235 REV

REV	REQ NO.	DESCRIPTION OF CHANGE	DRW	CHK	DES	PROJ	REL
		SEE SHEET 1.					

FUNCTION: Level Sensor
 PARAMETERS: Linear Displacement
 INPUT SCALE: Varying Voltage Divider
 OUTPUT SCALE: Gallons
 ACCURACY: ± 5%

CALCULATION:

$$V_{out\ max} = -10v \left(\frac{1.12k}{1.69k + 1.12k} \right) = -3.98$$

$$V_{out\ min} = 0v$$
 The sensor is a pot with approx. 10^A change for each 1" change in level from 0-115". Refer to Sensor Library for details.

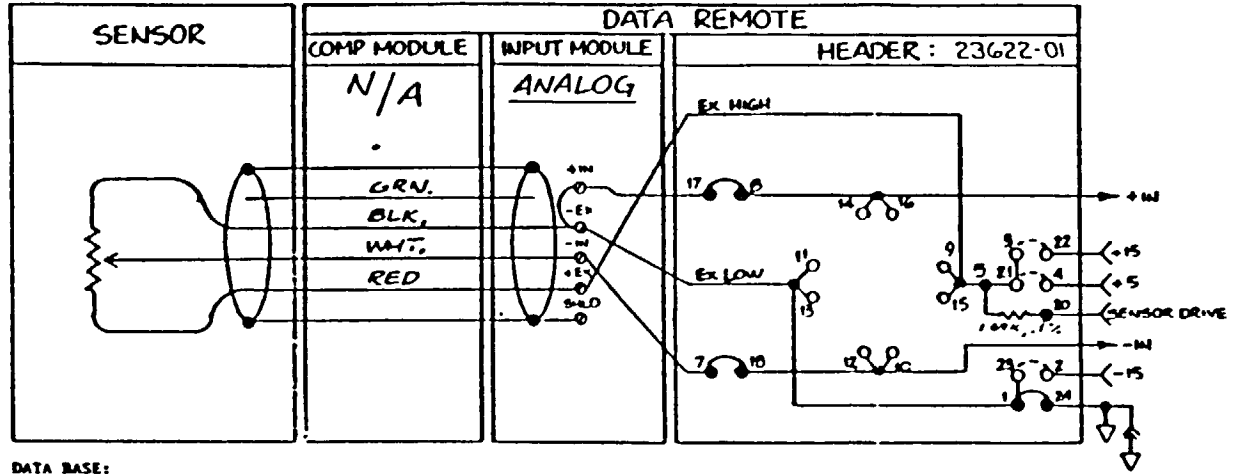

CALIBRATION:
 The display is generated from a non-linear lookup table. Use the formula

$$\left[\frac{(\text{Actual Reading} - \text{Displayed Reading}) \times 3840}{\text{Full Scale}} \right] + \text{OLD OFFSET}$$
 to generate a new offset. Repeat the new offset calculation until within 1% of Actual Reading.
 TEST: _____

DATA BASE:

SCALE	OFFSET	SPAN	RANGE	CAL
ACBL Tank Tables 112"	0	1902	0	6
ACBL (Bill Elmer) Tank Tables				
120"	0	1832	0	6
107"	0	1962	0	6
86"	0	2255	0	6

(Non-Linear Scale. Accurate 0)

DRW	MARCON SYSTEMS, INC			
RVANZANO	BELLEVUE, WASH. 98005			
CHK	DWG TITLE			
DES	SENSOR SPECIFICATION:			
PROJ	GENERAL,			
	GEMS TANK LEVEL SENSOR			
	CODE	REV	DWG NO	
	-	B	23285	
REL	SCALE	N/A	DO NOT SCALE DWG	SHEET 2 OF 3

REPAIR INSTRUCTIONS FOR TURBOCRAFT SINGLE STAGE CENTRIFUGAL PUMPS

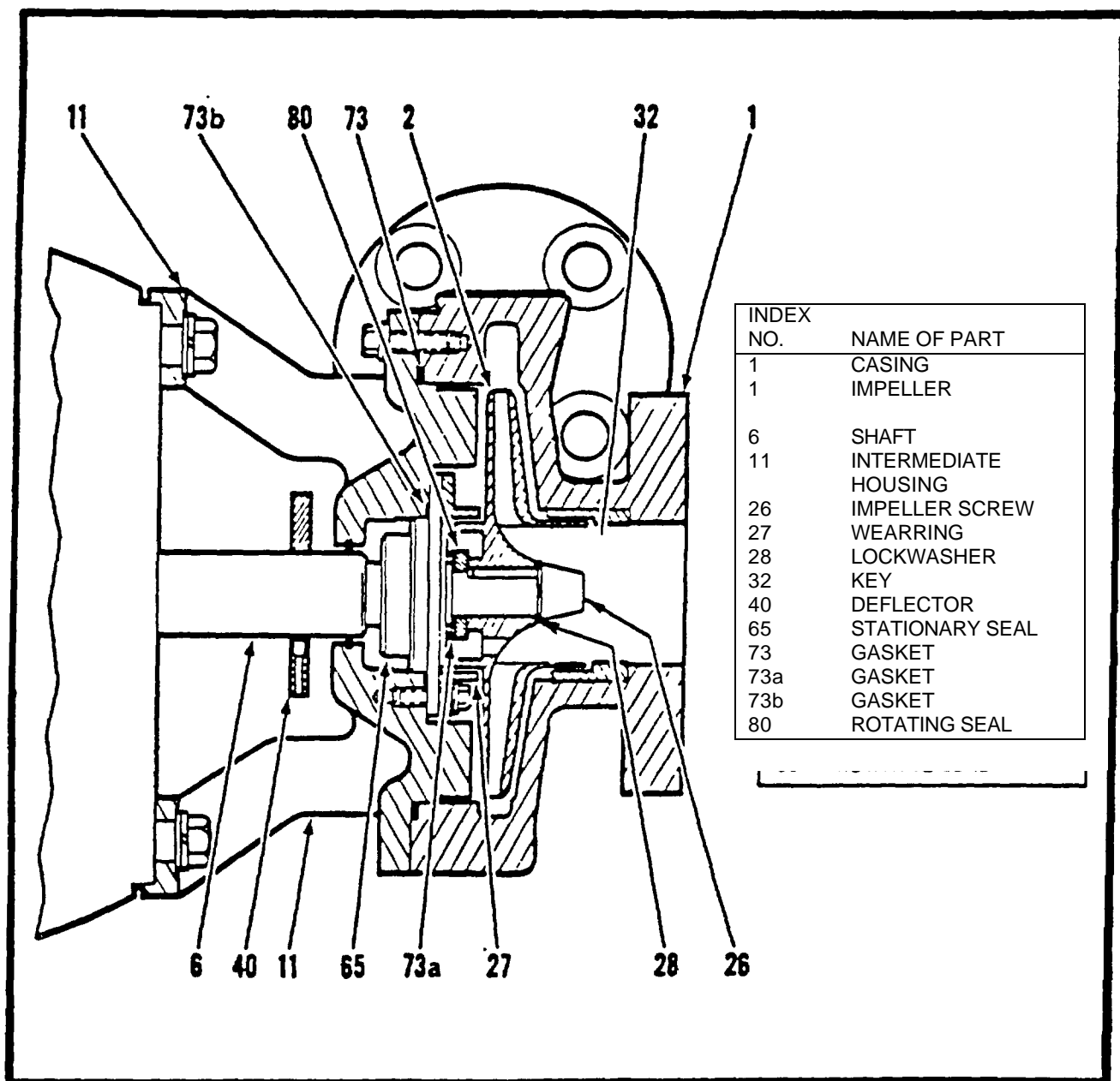

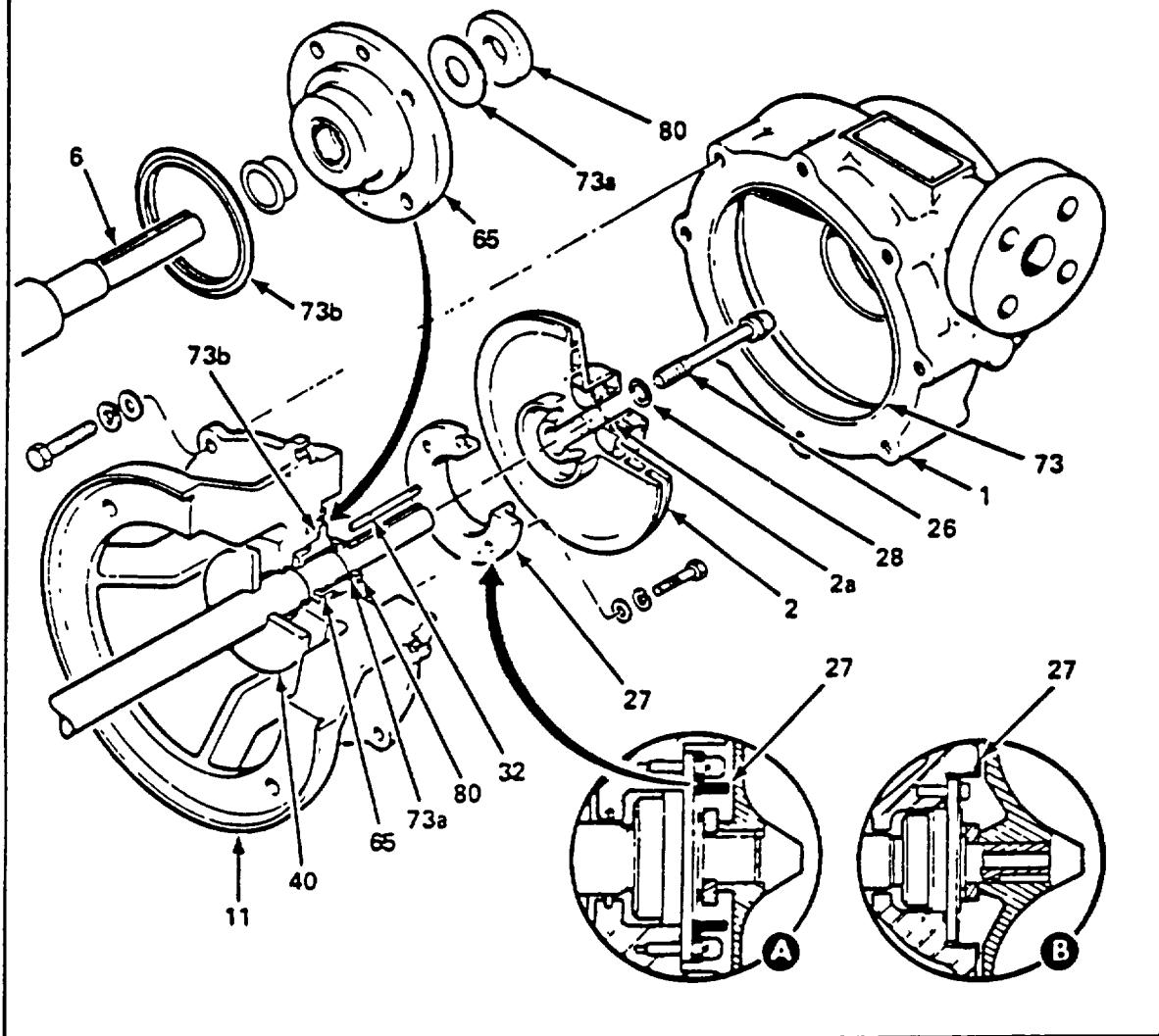

EXPLODED VIEW

ALL TURBOCRAFT single-stage pumps are assembled in the same sequential order although there are minor differences among the various sizes. The illustrations show the size 1 X 2 X 6 pump, which is typical except for the inducer (2a) which does not appear on other sizes. Details 'A' and 'B' on the center fold drawing show wear ring configurations on other sizes.

DISASSEMBLY

The pump must be at ambient temperature before disassembly. Repair must be carried out under conditions that are as clean as possible, especially if the pump is in oxygen service.

CAUTION

Be particularly careful not to mar the stainless steel shaft (6) or the surfaces of seals (65, 80).

- a. Remove casing (1) and gasket (73); discard gasket.
- b. Bend up the tab on lockwasher (28) and remove impeller screw (26) with an Allen wrench, discard lockwasher.

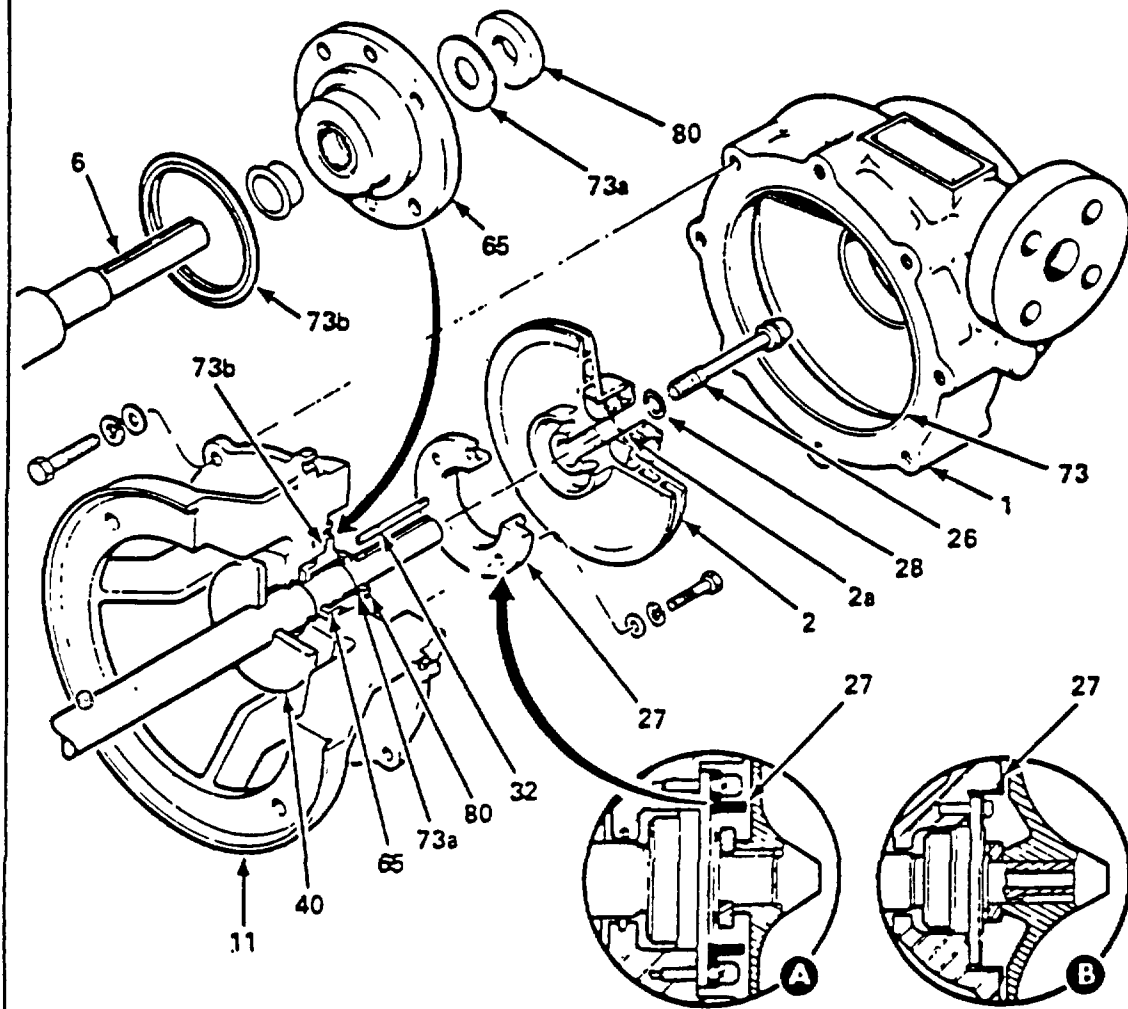

EXPLODED VIEW

ALL TURBOCRAFT single-stage pumps are assembled in the same sequential order although there are minor differences among the various sizes. The illustrations show the size 1 X 2 X 6 pump, which is typical except for the inducer (2a) which does not appear on other sizes. Details 'A' and 'B' on the center fold drawing show wear ring configurations on other sizes.

DISASSEMBLY

The pump must be at ambient temperature before disassembly. Repair must be carried out under conditions that are as clean as possible, especially if the pump is in oxygen service.

CAUTION

Be particularly careful not to mar the stainless steel shaft (6) or the surfaces of seals (65, 80).

- a. Remove casing (1) and gasket (73), discard gasket.
- b. Bend up the tab on lockwasher (28) and remove impeller screw (26) with an Allen wrench, discard lockwasher.

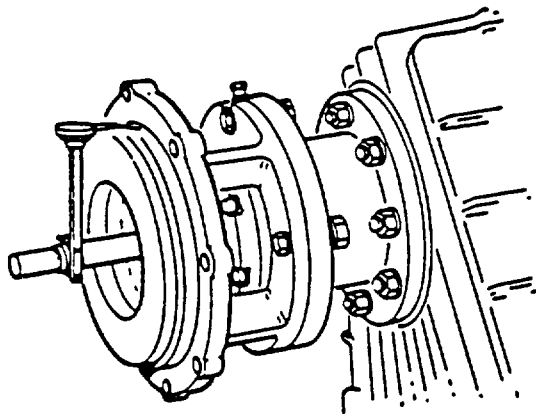

CONCENTRICITY MEASUREMENT

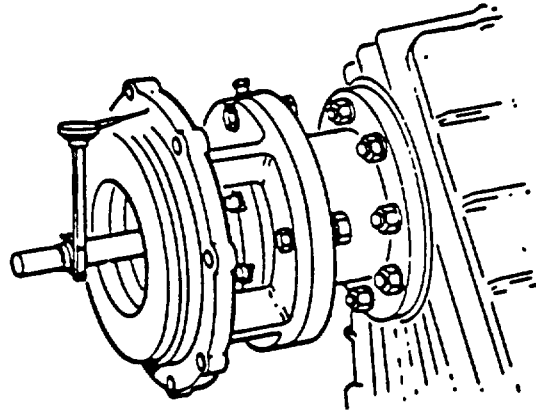

PARALLELISM MEASUREMENT

NOTE

The shaft must be prevented from rotating when removing impeller screw (26). This is best accomplished by holding the impeller (2) with one hand and tapping the Allen wrench with a small hammer until the impeller screw breaks loose.

- c. Remove inducer (2a) (size 1 X 2 X 6 only). Remove impeller (2) and key (32). Slide off seal ring (80) and gasket (73a). discard gasket.
- d. Unbolt and remove wear ring (27), stationary seal (65) and gasket (73b) discard gasket.

REASSEMBLY

- a. Check concentricity and parallelism of intermediate housing (11) by clamping a dial indicator on the shaft and turning the shaft through one complete rotation. Be sure to wrap the shaft before clamping on the indicator. Neither measurement may exceed 0.003 inch.
- b. If concentricity exceeds 0.003 inch, loosen the bolts holding intermediate housing (11) and rotate housing slightly in either direction until the proper reading is obtained, then tighten bolts. To adjust for parallelism, shim between the intermediate housing (11) and the motor or belt box to which the intermediate housing is mounted.

- c. Install gasket (73b) stationary seal (65) and wear ring (27). Line up the holes in wear ring (27) with the holes in the mounting flange of seal (65) and fasten wear ring and seal to the intermediate housing with the 6 bolts.
- d. Install gasket (73a) against stationary seal (65) Install rotating seal (80) with the dull surface of the seal (80) against the stationary seal (65) As a check the I.D of the rotating seal has one side which is beveled - this beveled side is the side which faces the stationary seal.
- e. Push against rotating seal (80) with the thumbs to compress stationary seal (65) and measure the total compression. This is measured with a dial indicator against the rotating seal (80). Total compression must be between 0.040 and 0.060 inch

NOTE

Step e. is a check against stationary seal (65). If reassembly to this point has been carried out correctly, the stationary seal (65) should show the proper compression; if not, the stationary seal must be replaced. Always replace stationary and rotating seals (65, 80) as a pair.

- f. Replace the rest of the parts in the reverse order of disassembly. When the Pump is completely assembled, rotate a few times by hand to see that there is no binding or rubbing.

By Order of the Secretary of the Army:

Official:

GORDON R. SULLIVAN
General, United States Army
Chief of Staff

MILTON H. HAMILTON
Administrative Assistant to the
Secretary of the Army
068S8

DISTRIBUTION

To be distributed in accordance with DA Form 12-25E, qty rqr block no. 3641, requirements for TM 55-1930-209-14&P-2.

RECOMMENDED CHANGES TO EQUIPMENT TECHNICAL PUBLICATIONS



THEN . JOT DOWN THE DOPE ABOUT IT ON THIS FORM. CAREFULLY TEAR IT OUT. FOLD IT AND DROP IT IN THE MAIL!

SOMETHING WRONG WITH THIS PUBLICATION?

FROM (PRINT YOUR UNIT'S COMPLETE ADDRESS)

PFC JOHN DOE
COA, 3d ENGINEER BN
FT. LEONARDWOOD, MO 63108

DATE SENT

PUBLICATION NUMBER

TM 55-1930-209-14&P-2

PUBLICATION DATE

15 OCTOBER 1992

PUBLICATION TITLE

Water Purification Barges Seawater System

BE EXACT PIN-POINT WHERE IT IS

PAGE NO	PARA-GRAPH	FIGURE NO	TABLE NO
---------	------------	-----------	----------

6	2-1 a		
B1		4-3	
125	line 20		

IN THIS SPACE TELL WHAT IS WRONG AND WHAT SHOULD BE DONE ABOUT IT:

In line 6 of paragraph 2-1a the manual states the engine has 6 cylinders. The engine on my set only has 4 cylinders. Change the manual to show 4 cylinders.

Callout 16 on figure 4-3 is pointing at a bolt. In key to figure 4-3, item 16 is called a shim - Please correct one or the other.

I ordered a gasket, item 19 on figure B-16 by NSN 2910-05-762-3001. I got a gasket but it doesn't fit. Supply says I got what I ordered, so the NSN is wrong. Please give me a good NSN

PRINTED NAME GRADE OR TITLE AND TELEPHONE NUMBER

JOHN DOE, PFC (268) 317-7111

SIGN HERE

JOHN DOE

DA FORM 2028-2
1 JUL 79

PREVIOUS EDITIONS ARE OBSOLETE
DRSTS-M Overprint 1, 1 Nov 80

PS--IF YOUR OUTFIT WANTS TO KNOW ABOUT YOUR RECOMMENDATION MAKE A CARBON COPY OF THIS AND GIVE IT TO YOUR HEADQUARTERS

TEAR ALONG PERFORATED LINE

FILL IN YOUR
UNIT'S ADDRESS



FOLD BACK

DEPARTMENT OF THE ARMY

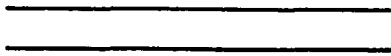

OFFICIAL BUSINESS

COMMANDER
U.S. ARMY TROOP SUPPORT COMMAND
ATTN: AMSTR-MMTS
4300 GOODFELLOW BOULEVARD
ST. LOUIS, MO 63120-1798

TEAR ALONG PERFORATED LINE

RECOMMENDED CHANGES TO EQUIPMENT TECHNICAL PUBLICATIONS



THEN . JOT DOWN THE DOPE ABOUT IT ON THIS FORM. CAREFULLY TEAR IT OUT. FOLD IT AND DROP IT IN THE MAIL!

SOMETHING WRONG WITH THIS PUBLICATION?

FROM (PRINT YOUR UNIT'S COMPLETE ADDRESS)

DATE SENT

PUBLICATION NUMBER

TM 55-1930-209-14&P-2

PUBLICATION DATE

15 OCTOBER 1992

PUBLICATION TITLE Water Purification
Barges Seawater System

BE EXACT PIN-POINT WHERE IT IS

PAGE NO	PARA-GRAPH	FIGURE NO	TABLE NO

IN THIS SPACE TELL WHAT IS WRONG AND WHAT SHOULD BE DONE ABOUT IT:

TEAR ALONG PERFORATED LINE

PRINTED NAME GRADE OR TITLE AND TELEPHONE NUMBER

SIGN HERE

DA FORM 2028-2
1 JUL 79

PREVIOUS EDITIONS ARE OBSOLETE.
DRST-M Overprint 2, 1 Nov 80.

P.S. --IF YOUR OUTFIT WANTS TO KNOW ABOUT YOUR RECOMMENDATION MAKE A CARBON COPY OF THIS AND GIVE IT TO YOUR HEADQUARTERS

FILL IN YOUR
UNIT'S ADDRESS



FOLD BACK

DEPARTMENT OF THE ARMY

OFFICIAL BUSINESS

COMMANDER
U.S. ARMY TROOP SUPPORT COMMAND
ATTN: AMSTR-MMTS
4300 GOODFELLOW BOULEVARD
ST. LOUIS, MO 63120-1798

TEAR ALONG PERFORATED LINE

The Metric System and Equivalents

Linear Measure

1 centimeter = 10 millimeters = .39 inch
 1 decimeter = 10 centimeters = 3.94 inches
 1 meter = 10 decimeters = 39.37 inches
 1 dekameter = 10 Meters = 32.8 feet
 1 hectometer = 10 dekameters = 328.08 feet
 1 kilometer = 10 hectometers = 3,280.8 feet

Weights

1 centigram = 10 milligrams = .15 grain
 1 decigram = 10 centigrams = 1.54 grains
 1 gram = 10 decigram = 0.35 ounce
 1 dekagram = 10 Grams = .35 ounce
 1 hectogram = 10 dekagrams = 3.52 ounces
 1 kilogram = 10 hectograms = 2.2 pounds
 1 quintal = 100 kilograms = 220.46 pounds
 1 metric ton = 10 quintals = 1.1 short tons

Liquid Measure

1 centiliter = 10 milliliters = .34 fluid ounce
 1 deciliter = 10 centiliters = 3.38 fluid ounces
 1 liter = 10 deciliters = 33.81 fluid ounces
 1 dekaliter = 10 liters = 2.64 gallons
 1 hectoliter = 10 dekaliters = 27.42 gallons
 1 kiloliter = 10 hectoliters = 264.18 gallons

Square Measure

1 sq. centimeter = 100 sq millimeters = .155 sq. inch
 1 sq. decimeter = 100 sq centimeters = 125.5 sq. inches
 1 sq. meter (centare) = 100 sq decimeters = 10.76 sq. feet
 1 sq. dekameter (are) = 1,076.4 sq. feet
 1 sq. hectometer (hectare) = 100 sq. dekameters = 2.47 acres
 1 sq. kilometer = 100 sq. hectometers = .386 sq. mile

Cubic Measure

1 cu. centimeter = 1000 cu. millimeters = .06 cu. inch
 1 cu. decimeter = 1000 cu. decimeters = 61.02 cu. inches
 1 cu. meter = 1000 cu. decimeters = 35.31 cu. feet

Approximate Conversion Factors

To change	To	Multiply by	To change	To	Multiply by
inches	centimeters	2.540	ounce-inches	newton-meters	.007062
feet	meters	.305	centimeters	inches	.394
yards	meters	.914	meters	feet	3.280
miles	kilometers	1.609	meters	yards	1.094
square inches	square centimeters	6.451	kilometers	miles	.621
square feet	square meters	.093	square centimeters	square inches	.155
square yards	square meters	.836	square meters	square feet	10.764
square miles	square kilometers	2.590	square meters	square yards	1.196
acres	square hectometers	.405	square kilometers	square miles	.386
cubic feet	cubic meters	.028	square hectometers	acres	2.471
cubic yards	cubic meters	.765	cubic meters	cubic feet	35.315
fluid ounces	milliliters	29.573	cubic meters	cubic yards	1.308
pints	liters	.473	milliliters	fluid ounces	.034
quarts	liters	.946	liters	pints	2.113
gallons	liters	3.785	liters	quarts	1.057
ounces	grams	28.349	liters	gallons	.264
pounds	kilograms	.454	grams	ounces	.035
short tons	metric tons	.907	kilograms	pounds	2.205
pound-feet	newton-meters	1.356	metric tons	short tons	1.102
pounds-inches	newton-meters	.11296			

Temperature (Exact)

°F Fahrenheit Temperature 5/9 (after subtracting 32) Celsius Temperature °C

